

## M12 Round Water-resistive Smartclick Connectors That Reduce Installation Work

- A locking mechanism compatible with standard M12 round connectors.
- Excellent environmental resistance enables waterproof and dustproof protection (IP67), ensuring stable connections even in harsh manufacturing environments.
- A simple 1/8 turn completes the connector mating, delivering high resistance to vibration and shock.
- Select the optimal connector to suit your application, whether for signal, communication, or power.



Smartclick

For the most recent information on models that have been certified for safety standards, refer to your OMRON website.

Refer to *Safety Precautions* on page 39.

## Features

### High compatibility with threaded connectors

XS5: One-touch Smart Click connection  
(Compatible with M12 threaded connectors)

Note: Threaded connection is used when connected to threaded connectors.

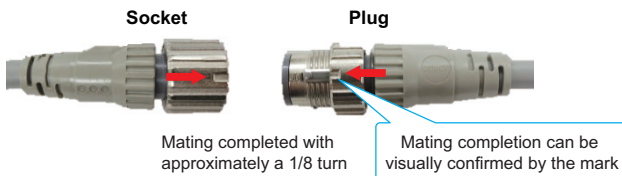

### Compatible with M12 threaded connectors

Can be connected to M12 threaded sensors and actuators

	XS5 Smart Click Plug	M12 Threaded Plug
XS5 Smart Click Socket	One-touch connection	Threaded connection
M12 Threaded Socket	Threaded connection	Threaded connection

All combinations are connectable.  
When connecting Smart Click to a threaded connector, a threaded connection is used.

Smartclick is a trademark or registered trademark of OMRON Corporation in Japan and other countries.

## Three Innovations That Solve On-site Challenges

### Maintenance-free

- No loosening due to machine vibration
- No risk of water ingress
- No periodic retightening required



### No torque management required

- Manual locking ensures consistent tightening torque
- Independent of operator skill

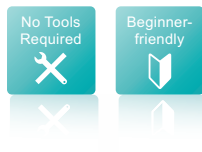

### Wiring Time Reduced

- Compared with M12 threaded connectors, connection time is reduced to approximately 1/3\*

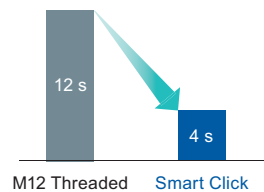

\* Comparison between OMRON's M12 threaded connectors and smartclick connectors. Based on internal OMRON comparison data.

## M12 Connector Applications & Features by Code

Application	Code	Typical Applications	Features
Signals XS5□-D	A-coding	<ul style="list-style-type: none"> <li>• Proximity sensors, photoelectric sensors</li> <li>• Actuators</li> <li>• I/O box connections</li> </ul>	<ul style="list-style-type: none"> <li>• The most widely used standard in FA environments</li> <li>• Supports 4, 5, and 8 poles</li> <li>• Can also be used for DC power supply</li> </ul>
Communication XS5□-T	D-coding	<ul style="list-style-type: none"> <li>• Industrial Ethernet such as EtherNet/IP® and EtherCAT®</li> <li>• Supports 100 Mbps communication</li> </ul>	<ul style="list-style-type: none"> <li>• 4 poles</li> <li>• Ensures stable communication even in noisy environments</li> </ul>
Power (AC) XS5□-S	S-coding	<ul style="list-style-type: none"> <li>• AC power supply</li> </ul>	<ul style="list-style-type: none"> <li>• Supports high voltages up to 630 V</li> <li>• Equipped with a PE (protective earth) terminal for safety</li> <li>• Compact design while capable of supplying AC power.</li> </ul>
Power (DC) XS5□-L	L-coding	<ul style="list-style-type: none"> <li>• DC fieldbus devices</li> <li>• DC motors</li> </ul>	<ul style="list-style-type: none"> <li>• Compact size supporting high current up to 12 A</li> <li>• Ideal for downsizing and replacement of conventional 7/8-inch connectors.</li> </ul>

# XS5□-D (A-coding)

**Compliant with global standards.  
UL certified and enables flexible wiring.**

- The PVC robot cable type (model suffix -F) is UL certified.
- Connection completed with just a 1/8 turn.  
The smart-click design dramatically reduces installation time.
- A lineup also includes 4 dia. slim robot cable types for easy routing.
- Four types of assembly-type connectors are available:  
insulation displacement, crimp, solder, and screw connection types.



For the most recent information on models that have been certified for safety standards, refer to your OMRON website.

## Ratings and Specifications

Item	Model	4 poles	5 poles	8 poles
Rated current		4 A *1	4 A	2 A
Rated voltage		250 VDC *2	60 V	30 V
Contact resistance (connector)		40 mΩ max.		
Insulation resistance		1,000 MΩ min. (at 500 VDC)		
Dielectric strength (connector)		1,500 VAC for 1 min (leakage current: 1 mA max.)	1,000 VAC for 1 min (leakage current: 1 mA max.)	
Insertion tolerance		50 times		
Ambient operating temperature range		-25 to 70°C *3		
Ambient humidity range		20% to 85%		
Degree of protection		IP67 (IEC60529)		

\*1. 3 A rating applies only to cable types with suffix -S or -PR-SA

\*2. 125 V rating applies only to cable types with suffix -SA

\*3. Use the robot cable within a temperature range between 0°C and 70°C to prevent the wires inside the cable from being broken when bending it.

Item	Model	Specifications
Pin block, Cover		PBT resin
Contacts		Copper alloy/Gold plated
Fixture		Zinc alloy/Nickel plated
Fixtures (Lock)		Stainless
O-ring		Rubber
Cable	PVC robot cable	UL AWM2464 CL3, 6 mm dia., AWG20 Sheath color: light gray
	Thin PVC robot cable	UL CL3, 4 mm dia., AWG20 Sheath color: black
	Polyurethane robot cable	4.7 mm dia. AWG23 Sheath color: black
	Spatter-resistant Cable	6.6 mm dia. AWG20 Sheath color: blue

For Signal (A-coding)

For Communication (D-coding)

For Power (L/S-coding)

Common Accessories

Common Precautions

Pin Arrangement (Engaged Side)

Item	No. of poles	4 poles	5 poles	8 poles
A-coding (DC type)	Male (plug) contacts			
	Female (socket) contacts			

Connection

OMRON model No.		Smartclick Plug Connectors	M12 Plug Connectors
		XS5H, XS5G, XS5W (plug side), XS5R (plug side), XS5M	XS2H, XS2G, XS2W (plug side), XS2R (plug side), XS2M
Smartclick Socket Connectors	XS5F, XS5C, XS5W (socket side), XS5R (socket side), XS5P	⊙	○
M12 Socket Connectors	XS2F, XS2C, XS2W (socket side), XS2R (socket side), XS2P	○	○

⊙: Connected by twisting.

○: Connected by screwing.

Note: The XS□M and XS□P cannot mate with each other.

For Signal (A-coding)

For Communication (D-coding)

For Power (L/S-coding)

Common Accessories

Common Precautions

# XS5W-D For Signal, Socket and Plug on Both Cable Ends

## Model Number Structure

### Model Number Legend

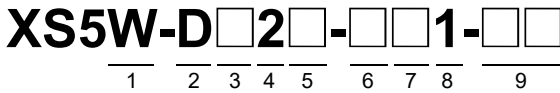

Use this model number legend to identify products from their model number.  
Use this model number legend to identify products from their model number. When ordering, use a model number from the table in *Ordering Information*.

#### 1. Type

W: Connectors with cables, socket and plug on both cable ends

#### 2. Mating Section Form

D: A-coding (DC type)

#### 3. Connector Poles

- 4: 4 poles
- 5: 5 poles
- 8: 8 poles

#### 4. Contact Plating

2: Gold plating

#### 5. Cable Connection Direction

- 1: Straight/straight
- 2: Right-angle (Socket)/right-angle (Plug)
- 3: Straight (Socket)/right-angle (Plug)
- 4: Right-angle (Socket)/straight (Plug)
- 5: Straight (Socket)/straight (Plug) 4 dia.
- B: Straight (Socket)/straight (Plug) 4.7 dia.

#### 6. Cable Length

- B: 0.5 m    C: 1 m      D: 2 m
- E: 3 m      G: 5 m      J: 10 m
- K: 15 m     L: 20 m

#### 7. Connections (Numbers inside circles are terminal numbers)

- 8: ① Brown, ② White, ③ Blue, ④ Black
- G: ① Brown, ② White, ③ Blue, ④ Black, ⑤ Gray
- K: ① Brown, ② White, ③ Blue, ④ Black, ⑤ Gray, ⑥ Pink, ⑦ Purple, ⑧ Orange

#### 8. Connectors on One Cable End/Both Ends





- 1: Connectors on both cable ends

#### 9. Cable Specifications

- F: PVC robot cable
- S: Thin PVC robot cable
- PR: Polyurethane robot cable
- SA: Spatter-resistant cable

## Ordering Information

### PVC robot cable 4 poles/5 poles/8 poles

Shape	Cable length L (m)	4 poles	5 poles	8 poles
		Model	Model	Model
Straight 	0.5	XS5W-D421-B81-F	XS5W-D521-BG1-F	XS5W-D821-BK1-F
	1	XS5W-D421-C81-F	XS5W-D521-CG1-F	XS5W-D821-CK1-F
	2	XS5W-D421-D81-F	XS5W-D521-DG1-F	XS5W-D821-DK1-F
	3	XS5W-D421-E81-F	XS5W-D521-EG1-F	XS5W-D821-EK1-F
	5	XS5W-D421-G81-F	XS5W-D521-GG1-F	XS5W-D821-GK1-F
	10	XS5W-D421-J81-F	XS5W-D521-JG1-F	XS5W-D821-JK1-F
	15	XS5W-D421-K81-F	XS5W-D521-KG1-F	XS5W-D821-KK1-F
	20	XS5W-D421-L81-F	XS5W-D521-LG1-F	XS5W-D821-LK1-F
Right-angle (Socket)/right-angle (Plug) 	2	XS5W-D422-D81-F	---	---
	5	XS5W-D422-G81-F	---	---
Straight (Socket)/right-angle (Plug) 	2	XS5W-D423-D81-F	---	---
	5	XS5W-D423-G81-F	---	---
Right-angle (Socket)/straight (Plug) 	2	XS5W-D424-D81-F	---	---
	5	XS5W-D424-G81-F	---	---

Note: The PVC robot cable type is certified under UL 2238 (UL File No. E207683).

### Other cable specifications 4 poles

Shape	Cable length L (m)	Polyurethane robot cable	Thin PVC robot cable	Spatter-resistant cable
		Model	Model	Model
Straight 	0.5	---	XS5W-D425-B81-S	---
	1	XS5W-D42B-C81-PR	XS5W-D425-C81-S	---
	2	XS5W-D42B-D81-PR	XS5W-D425-D81-S	XS5W-D421-D81-SA
	3	---	XS5W-D425-E81-S	---
	5	XS5W-D42B-G81-PR	XS5W-D425-G81-S	XS5W-D421-G81-SA
	10	XS5W-D42B-J81-PR	XS5W-D425-J81-S	---

Note: The thin PVC robot cable type is certified under UL 2238 (UL File No. E207683).

For Signal (A-coding)

For Communication (D-coding)

For Power (L/S-coding)

Common Accessories

Common Precautions

**Dimensions**

**Straight/Straight**  
**XS5W-D□21-□□1-F**  
**XS5W-D42B-□□81-PR**  
**XS5W-D425-□□81-S**  
**XS5W-D421-□□81-SA**



XS5W-D421-□□81-F (shown above)

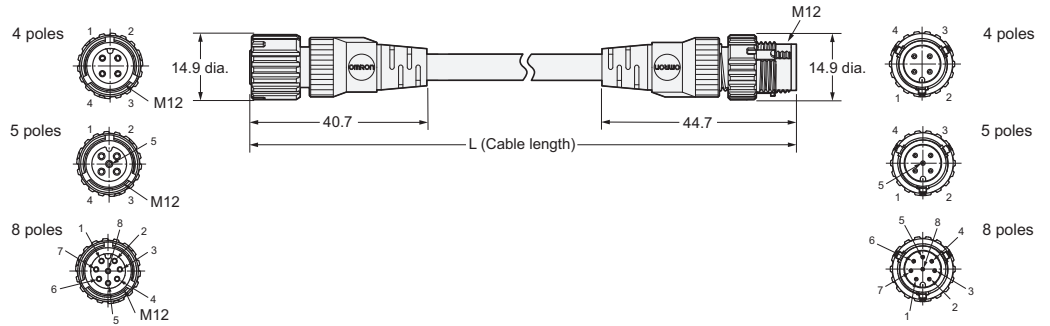

**Right-angle (Socket)/Right-angle (Plug)**  
**XS5W-D422-□□81-F**

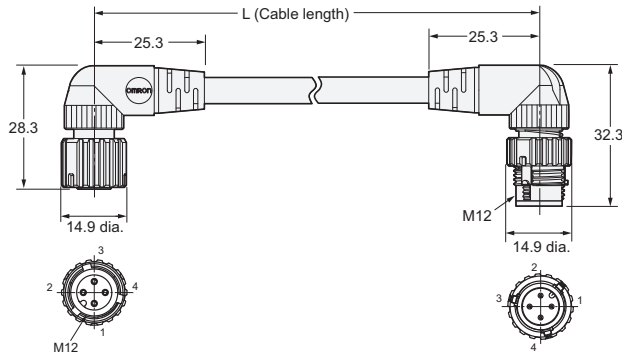

**Straight (Socket)/Right-angle (Plug)**  
**XS5W-D423-□□81-F**

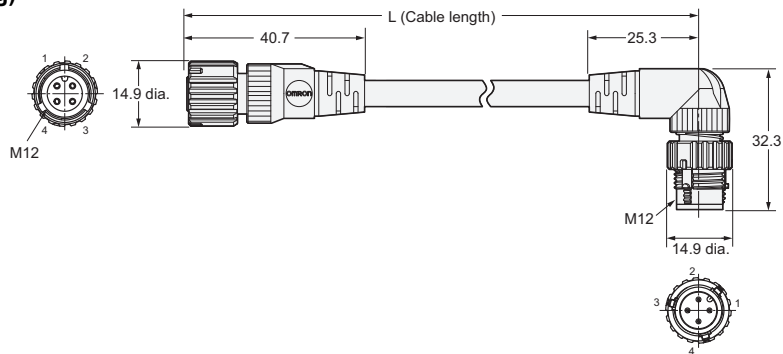

**Right-angle (Socket)/Straight (Plug)**  
**XS5W-D424-□□81-F**

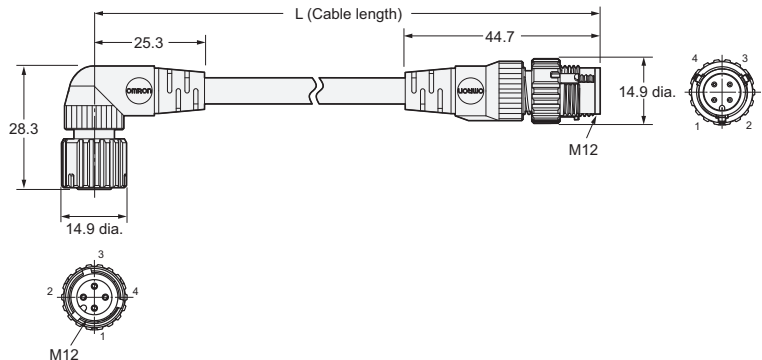

**Wiring Diagram for 4 Cores**

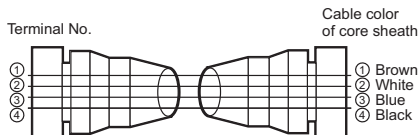

**Wiring Diagram for 5 Cores**

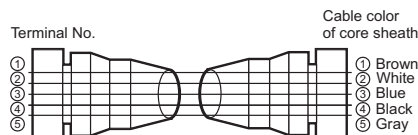

**Wiring Diagram for 8 Cores**

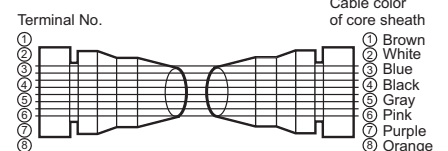

Note: Spatter-resistant cables (XS5W-D421-□□81-SA) have black covers.

PVC robot cables (XS5W-D□2□□□81-F), PVC robot cables (XS5W-D425-□□81-S), polyurethane robot cables (XS5W-D42B-□□81-PR) have warm gray covers.

For Signal (A-coding)

For Communication (D-coding)

For Power (L/S-coding)

Common Accessories

Common Precautions

# XS5F-D For Signal, Socket on One Cable End

## Model Number Structure

### Model Number Legend

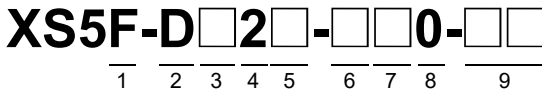

Use this model number legend to identify products from their model number.  
Use this model number legend to identify products from their model number. When ordering, use a model number from the table in *Ordering Information*.

#### 1. Type

F: Connectors with cables  
Socket on one cable end

#### 2. Mating Section Form

D: A-coding (DC type)

#### 3. Connector Poles

4: 4 poles  
5: 5 poles  
8: 8 poles

#### 4. Contact Plating

2: Gold plating

#### 5. Cable Connection Direction

1: Straight  
2: Right-angle  
3: Straight (4 dia.)  
B: Straight (4.7 dia.)  
C: Right-angle (4.7 dia.)

#### 6. Cable Length

B: 0.5 m    C: 1 m    D: 2 m  
E: 3 m    G: 5 m    H: 7 m  
J: 10 m    K: 15 m    L: 20 m

#### 7. Connections (Numbers inside circles are terminal numbers)

8: ① Brown, ② White, ③ Blue, ④ Black  
G: ① Brown, ② White, ③ Blue, ④ Black, ⑤ Gray  
K: ① Brown, ② White, ③ Blue, ④ Black, ⑤ Gray, ⑥ Pink, ⑦ Purple, ⑧ Orange

#### 8. Connectors on One Cable End/ Both Ends



0: One cable end

#### 9. Cable Specifications

F: PVC robot cable  
S: Thin PVC robot cable  
PR: Polyurethane robot cable  
SA: Spatter-resistant cable



## Ordering Information

### PVC robot cable 4 poles/5 poles/8 poles

Shape	Cable length L (m)	4 poles	5 poles	8 poles
		Model	Model	Model
Straight 	0.5	XS5F-D421-B80-F	XS5F-D521-BG0-F	XS5F-D821-BK0-F
	1	XS5F-D421-C80-F	XS5F-D521-CG0-F	XS5F-D821-CK0-F
	2	XS5F-D421-D80-F	XS5F-D521-DG0-F	XS5F-D821-DK0-F
	3	XS5F-D421-E80-F	XS5F-D521-EG0-F	XS5F-D821-EK0-F
	5	XS5F-D421-G80-F	XS5F-D521-GG0-F	XS5F-D821-GK0-F
	10	XS5F-D421-J80-F	XS5F-D521-JG0-F	XS5F-D821-JK0-F
	15	XS5F-D421-K80-F	XS5F-D521-KG0-F	XS5F-D821-KK0-F
	20	XS5F-D421-L80-F	XS5F-D521-LG0-F	XS5F-D821-LK0-F
Right-angle 	1	XS5F-D422-C80-F	---	---
	2	XS5F-D422-D80-F	---	---
	5	XS5F-D422-G80-F	---	---
	10	XS5F-D422-J80-F	---	---

Note: The PVC robot cable type is certified under UL 2238 (UL File No. E207683).

### Other cable specifications 4 poles

Shape	Cable length L (m)	Polyurethane robot cable	Thin PVC robot cable	Spatter-resistant cable
		Model	Model	Model
Straight 	1	XS5F-D42B-C80-PR	XS5F-D423-C80-S	---
	2	XS5F-D42B-D80-PR	XS5F-D423-D80-S	XS5F-D421-D80-SA
	5	XS5F-D42B-G80-PR	XS5F-D423-G80-S	XS5F-D421-G80-SA
	10	XS5F-D42B-J80-PR	XS5F-D423-J80-S	---
Right-angle 	1	XS5F-D42C-C80-PR	---	---
	2	XS5F-D42C-D80-PR	---	---
	5	XS5F-D42C-G80-PR	---	---
	10	XS5F-D42C-J80-PR	---	---

Note: The thin PVC robot cable type is certified under UL 2238 (UL File No. E207683).

For Signal (A-coding)

For Communication (D-coding)

For Power (L/S-coding)

Common Accessories

Common Precautions

**Dimensions**

**Straight**

- XS5F-D□21-□□0-F
- XS5F-D42B-□80-PR
- XS5F-D423-□80-S
- XS5F-D421-□80-SA



XS5F-D421-□□0-F (shown above)

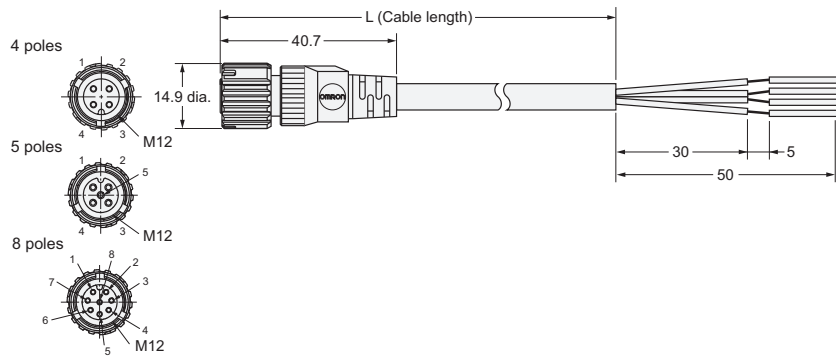

**Right-angle**

- XS5F-D422-□80-F
- XS5F-D42C-□80-PR



XS5F-D422-□80-F (shown above)

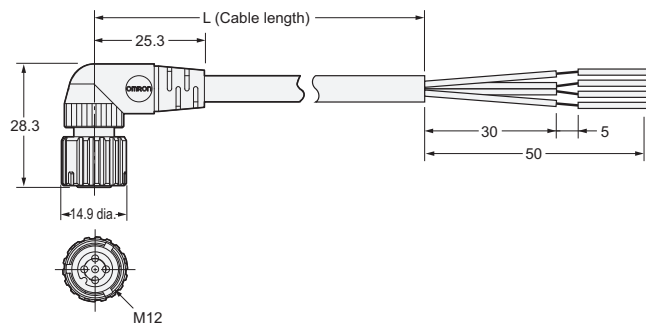

**Wiring Diagram for 4 Cores**

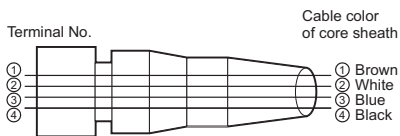

**Wiring Diagram for 5 Cores**

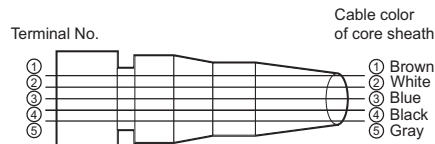

**Wiring Diagram for 8 Cores**

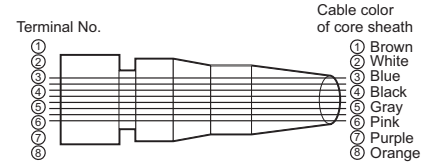

Note: Spatter-resistant cables (XS5F-D421-□80-SA) have black covers.  
 PVC robot cables (XS5F-D□2□-□80-F), thin PVC robot cables (XS5F-D423-□80-S),  
 polyurethane robot cables (XS5F-D42□-□80-PR) have warm gray covers.

For Signal (A-coding)

For Communication (D-coding)

For Power (L/S-coding)

Common Accessories

Common Precautions



**Dimensions**

**Straight**  
**XS5H-D□21-□□0-F**  
**XS5H-D423-□80-S**  
**XS5H-D421-□80-SA**



XS5H-D421-□80-F (shown above)

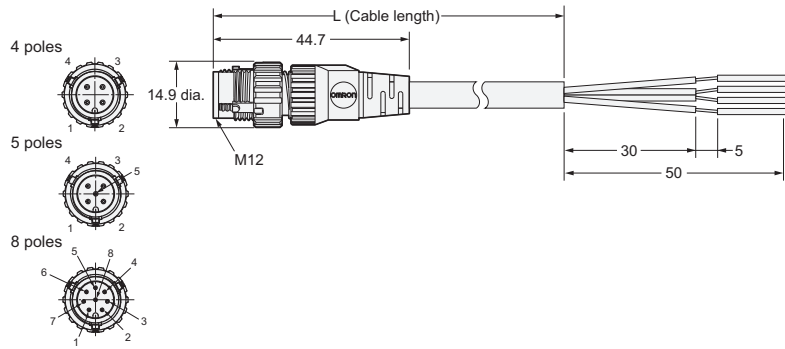

**Right-angle**  
**XS5H-D422-□80-□**



XS5H-D422-□80-□ (shown above)

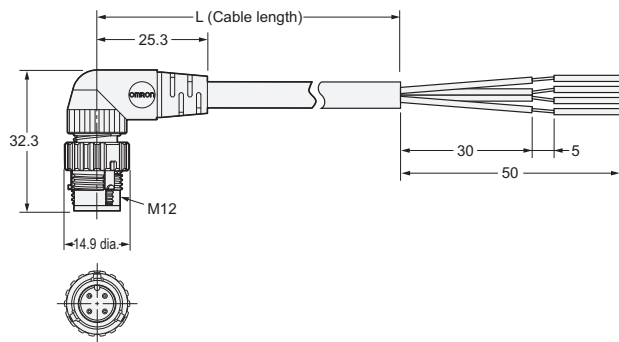

**Wiring Diagram for 4 Cores**

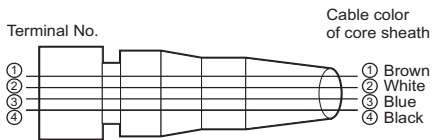

**Wiring Diagram for 5 Cores**

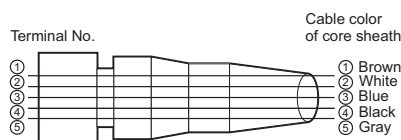

**Wiring Diagram for 8 Cores**

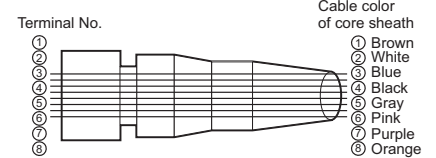

Note: Spatter-resistant cables (XS5H-D421-□80-SA) have black covers. PVC robot cables (XS5H-D□2□-□80-F) have warm gray covers.

For Signal (A-coding)

For Communication (D-coding)

For Power (L/S-coding)

Common Accessories

Common Precautions

# XS5G-D Assembly Connector Plugs

## Ordering Information

No. of poles	Connection method	Suitable cable (mm)	Core conductor size (mm <sup>2</sup> )	Suitable sheath material	Straight Connectors	Right-angle Connectors	UL	
					Model	Model		
4	IDC	3 to 8 dia.	0.14 to 0.75 *1	PVC, PE, PUR	XS5G-D418	—	UL2238 certified (File no. E207683)	
	Crimping	6 dia. (5 to 6 dia.)	0.18 to 0.3 0.5 to 0.75 *2		XS5G-D4C1	—		
		4 dia. (4 to 5 dia.)			XS5G-D4C3	—		
		3 dia. (3 to 4 dia.)			XS5G-D4C5	—		
	Soldering	6 dia. (5 to 6 dia.)	0.5 max.		XS5G-D421	XS5G-D422		
		4 dia. (4 to 5 dia.)			XS5G-D423	XS5G-D424		
		3 dia. (3 to 4 dia.)			XS5G-D425	XS5G-D426		
	Screw-on	6 dia. (5 to 6 dia.)	0.18 to 0.75		XS5G-D4S1	XS5G-D4S2		
		4 dia. (4 to 5 dia.)			XS5G-D4S3	XS5G-D4S4		
		3 dia. (3 to 4 dia.)			XS5G-D4S5	XS5G-D4S6		
		8 dia. (7 to 8 dia.)			XS5G-D4S7	—		
		7 dia. (6 to 7 dia.)			XS5G-D4S9	—		
	5	Screw-on	6 dia. (5 to 6 dia.)		0.18 to 0.75	XS5G-D5S1		—
			4 dia. (4 to 5 dia.)			XS5G-D5S3		—
3 dia. (3 to 4 dia.)			XS5G-D5S5	—				
8 dia. (7 to 8 dia.)			XS5G-D5S7	—				
7 dia. (6 to 7 dia.)			XS5G-D5S9	—				

\*1. Minimum wire diameter: 0.08 mm, External sheath diameter of wire covering: 0.7 to 2.6 mm, Material of wire covering: PVC and PE

\*2. There are two types of contacts. Crimping pins for XS5G-D4C□ are not included and are sold separately.

Note: XS5G Screw-on Plugs cannot be connected to side by side to the CN1 and CN2 connectors of XS2R or XS5R Y-Joint Sockets/Plugs.  
Use a cable of mentioning. If you do not use one of these cables, there is a possibility that the performance can't be met.

### Accessories (Order Separately)

#### Crimping Pin for XS5G

Suitable core size (mm <sup>2</sup> )	Model
0.18 to 0.3	XS5U-3121
0.5 to 0.75	XS5U-3122

**Dimensions**

**Straight Connectors  
XS5G-D418 (IDC Model)**

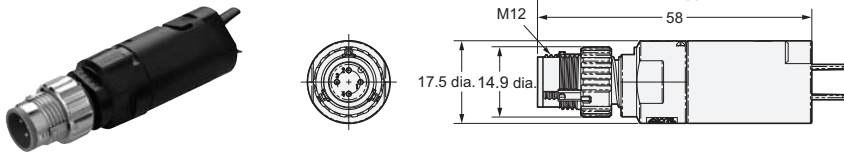

**Straight Connectors  
XS5G-D4C□ (Crimping Model)  
XS5G-D42□ (Soldering Model)**

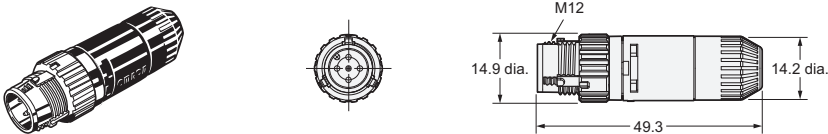

**Straight Connectors  
XS5G-D□S□ (Screw-on Connectors)**

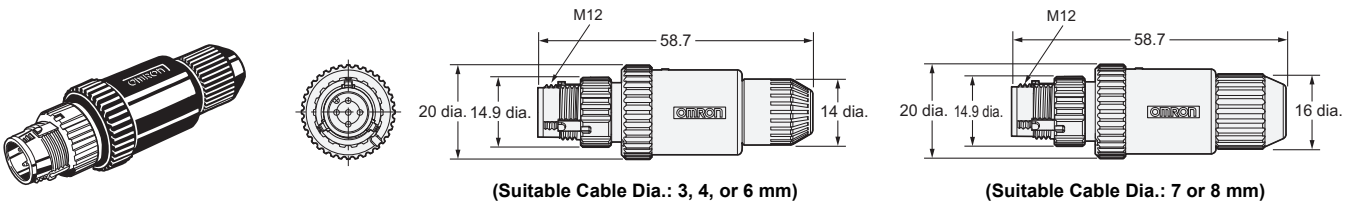

**Right-angle Connectors  
XS5G-D42□ (Soldering Model)**

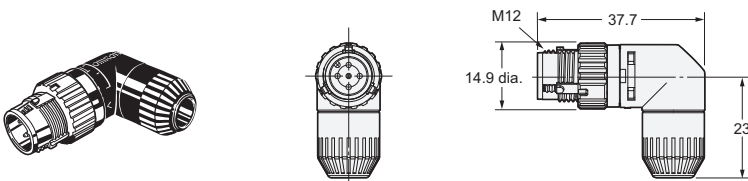

**Right-angle Connectors  
XS5G-D□S□ (Screw-on Connectors)**

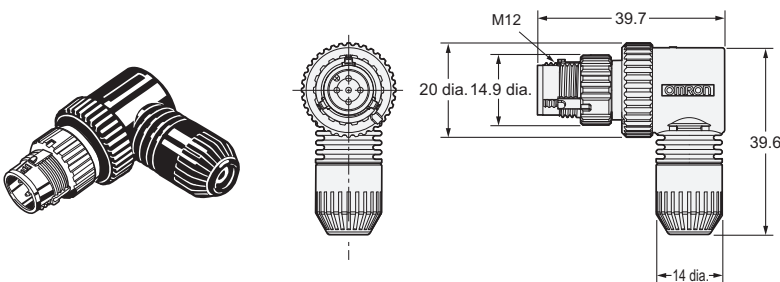

**Crimping Pin for XS5G  
XS5U-312□**

\* A special tool must be used for crimping. For details, refer to page 33.

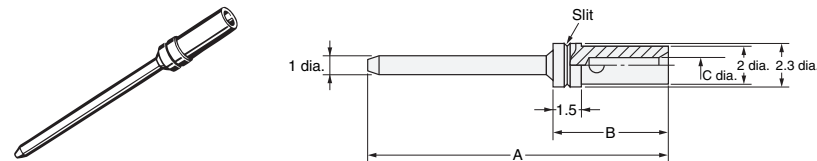

**Dimensions**

Model	Suitable core size (mm <sup>2</sup> )	Dimension (mm)			No. of slits
		A	B	C	
XS5U-3121	0.18 to 0.3	22.6	6.1	0.8	1
XS5U-3122	0.5 to 0.75	22.7	6.2	1.3	0

For Signal (A-coding)

For Communication (D-coding)

For Power (L/S-coding)

Common Accessories

Common Precautions

# XS5C-D Assembly Connector Sockets

## Ordering Information

No. of poles	Connection method	Suitable cable (mm)	Core conductor size (mm <sup>2</sup> )	Suitable sheath material	Straight Connectors	Right-angle Connectors	UL
					Model	Model	
4	IDC	3 to 8 dia.	0.14 to 0.75 *1	PVC, PE, PUR	<b>XS5C-D418</b>	—	UL2238 certified (File no. E207683)
	Crimping	6 dia. (5 to 6 dia.)	0.18 to 0.3 0.5 to 0.75 *2		<b>XS5C-D4C1</b>	<b>XS5C-D4C2</b>	
		4 dia. (4 to 5 dia.)			<b>XS5C-D4C3</b>	<b>XS5C-D4C4</b>	
		3 dia. (3 to 4 dia.)			<b>XS5C-D4C5</b>	<b>XS5C-D4C6</b>	
	Soldering	6 dia. (5 to 6 dia.)	0.5 max.		<b>XS5C-D421</b>	<b>XS5C-D422</b>	
		4 dia. (4 to 5 dia.)			<b>XS5C-D423</b>	<b>XS5C-D424</b>	
		3 dia. (3 to 4 dia.)			<b>XS5C-D425</b>	<b>XS5C-D426</b>	
	Screw-on	6 dia. (5 to 6 dia.)	0.18 to 0.75		<b>XS5C-D4S1</b>	<b>XS5C-D4S2</b>	
		4 dia. (4 to 5 dia.)			<b>XS5C-D4S3</b>	<b>XS5C-D4S4</b>	
		3 dia. (3 to 4 dia.)			<b>XS5C-D4S5</b>	<b>XS5C-D4S6</b>	
		8 dia. (7 to 8 dia.)			<b>XS5C-D4S7</b>	—	
	5	Screw-on	7 dia. (6 to 7 dia.)		0.18 to 0.75	<b>XS5C-D4S9</b>	
6 dia. (5 to 6 dia.)			<b>XS5C-D5S1</b>	—			
4 dia. (4 to 5 dia.)			<b>XS5C-D5S3</b>	—			
3 dia. (3 to 4 dia.)			<b>XS5C-D5S5</b>	—			
8 dia. (7 to 8 dia.)			<b>XS5C-D5S7</b>	—			
		7 dia. (6 to 7 dia.)		<b>XS5C-D5S9</b>	—		

\*1. Minimum wire diameter: 0.08 mm, External sheath diameter of wire covering: 0.7 to 2.6 mm, Material of wire covering: PVC and PE

\*2. There are two types of contacts. Crimping pins for XS5C-D4C□ are not included and are sold separately.

Note: Use a cable of mentioning. If you do not use one of these cables, there is a possibility that the performance can't be met.

### Accessories (Order Separately)

#### Crimping Pin for XS5C

Suitable core size (mm <sup>2</sup> )	Model
0.18 to 0.3	<b>XS5U-2221</b>
0.5 to 0.75	<b>XS5U-2222</b>

**Dimensions**

**Straight Connectors  
XS5C-D418 (IDC Model)**

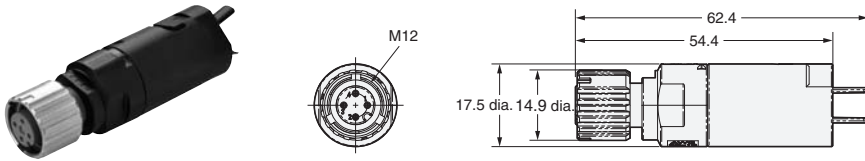

**Straight Connectors  
XS5C-D4C□ (Crimping Model)  
XS5C-D42□ (Soldering Model)**

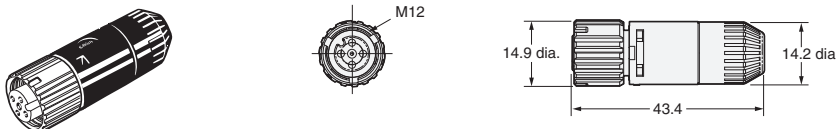

**Straight Connectors  
XS5C-D□S□ (Screw-on Connectors)**

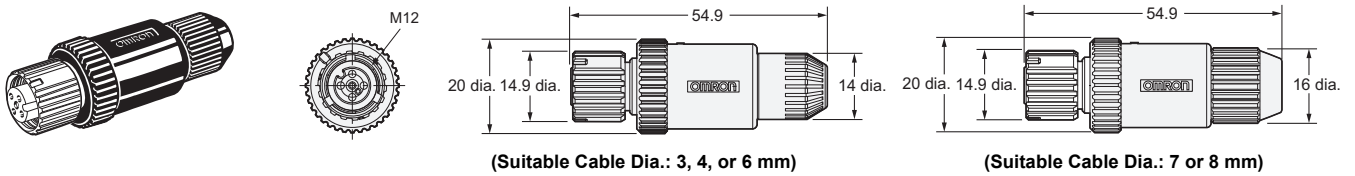

**Right-angle Connectors  
XS5C-D4C□ (Crimping Model)  
XS5C-D42□ (Soldering Model)**

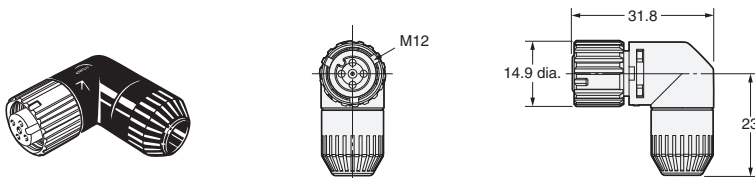

**Right-angle Connectors  
XS5C-D□S□ (Screw-on Connectors)**

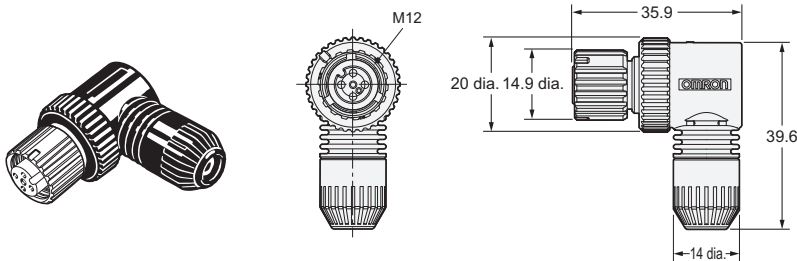

**Crimping Pin for XS5C  
XS5U-222□**

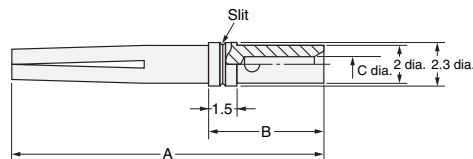

\* A special tool must be used for crimping. For details, refer to page 33.

**Dimensions**

Model	Suitable core size (mm <sup>2</sup> )	Dimension (mm)			No. of slits
		A	B	C	
XS5U-2221	0.18 to 0.3	16.7	6.1	0.8	1
XS5U-2222	0.5 to 0.75	16.8	6.2	1.3	0

For Signal (A-coding)

For Communication (D-coding)

For Power (L/S-coding)

Common Accessories

Common Precautions

# XS5R-D Y-Joint Plug/Socket Connectors

## Ordering Information

Cable	Connector	Cable length (m)	Model	UL
With cable	Connectors on both cable ends	0.5	XS5R-D426-B11-F	UL2238 certified (File no. E207683)
		1	XS5R-D426-C11-F	
		2	XS5R-D426-D11-F	
		3	XS5R-D426-E11-F	
	Connector on one cable end	2	XS5R-D426-D10-F	
		5	XS5R-D426-G10-F	

Cable	Connector	Cable length (m)	Model	UL
Without cable	Connectors on both cable ends	—	XS5R-D426-1	UL2238 certified (File no. E207683)
			XS5R-D426-5	

Note 1. Ask your OMRON representative about other specifications.

2. XS2G/XS5G Assembled Connectors with screw-on connections cannot be connected to both CN1 and CN2 at the same time.

## Dimensions

(Unit: mm)

### Connectors on Both Cable Ends (Y-Joint Plug/Socket) XS5R-D426-□11-F

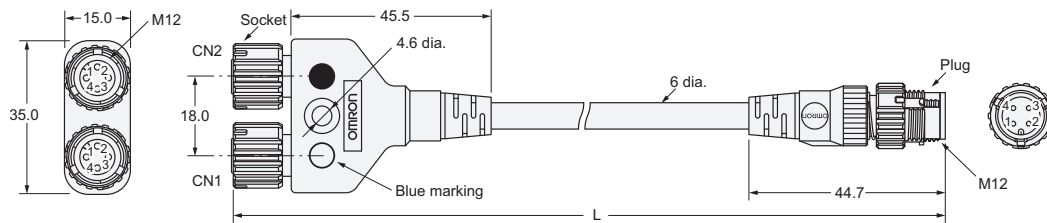

#### Wiring Diagram

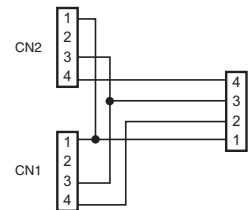

### Connectors on One Cable End (Y-Joint Socket) XS5R-D426-□10-F

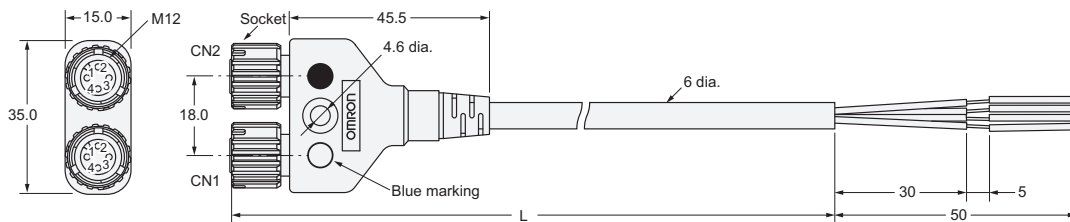

#### Wiring Diagram

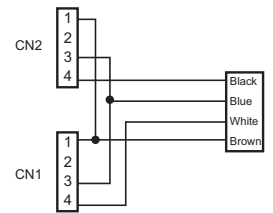

### Connectors on Both Cable Ends (Y-Joint Plug/Socket) XS5R-D426-□

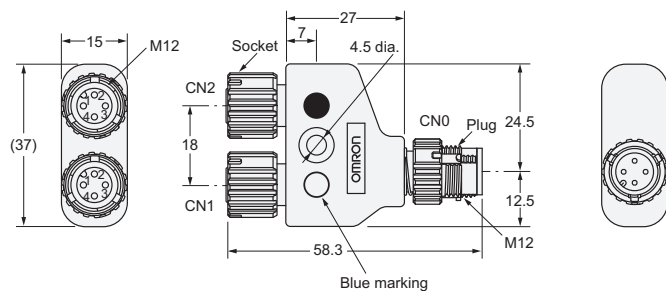

#### Wiring Diagram

##### XS5R-D426-1

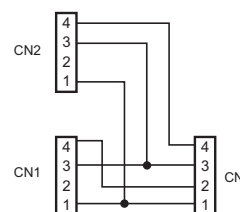

##### XS5R-D426-5

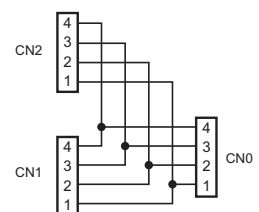

For Signal (A-coding)

For Communication (D-coding)

For Power (L/S-coding)

Common Accessories

Common Precautions

# XS5P-D Panel-mounting Sockets

## Ordering Information

Type	No. of poles	Lock	Wire length (m)	Model	UL
With wire	4	Rear lock	0.5	XS5P-D426-5	UL2238 certified (File no. E207683)
		Front lock		XS5P-D427-5	
Type	No. of poles	Lock *	Applicable wires	Model	UL
Solder cup pins	4	Rear lock	AWG20 to AWG28	XS5P-D426-4	—
		Front lock		XS5P-D427-4	
	5	Rear lock		XS5P-D526-4	
		Front lock		XS5P-D527-4	

\*Install the rear lock type from the front of the panel and tighten the nut from the rear.  
Install the front lock type from the rear of the panel and tighten the nut from the front.

## Dimensions

(Unit: mm)

### With wire

#### Rear lock XS5P-D426-5

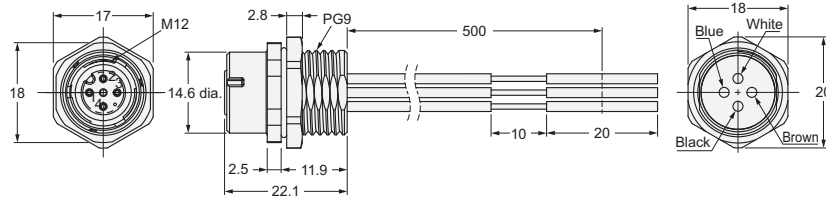

#### Wiring

Pin No.	Color
1	Brown
2	White
3	Blue
4	Black

#### Front lock XS5P-D427-5

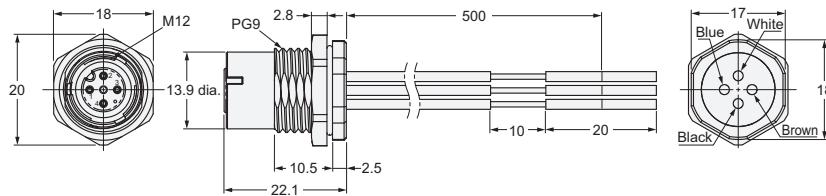

#### Wire Specifications

Specification	UL1007	
Nominal size	AWG20	
Configuration	Number of wires	21
	Wire diameter	0.18
	Standard outer diameter	1.8

### Solder cup pins

#### Rear lock XS5P-D426-4

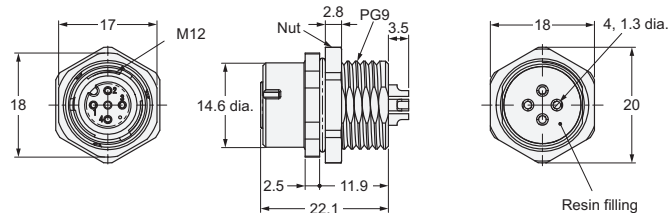

#### Rear lock XS5P-D526-4

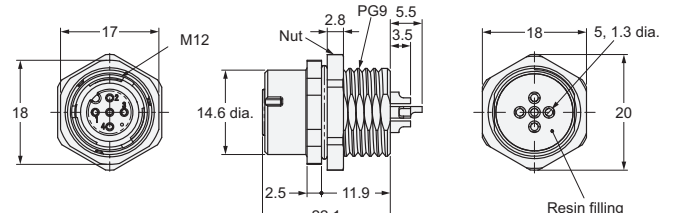

#### Front lock XS5P-D427-4

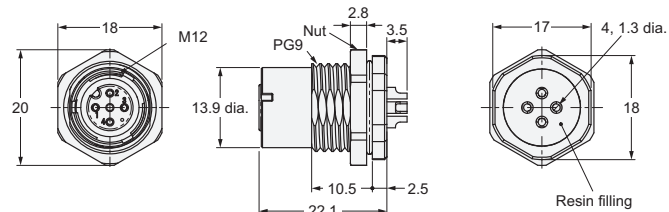

#### Front lock XS5P-D527-4

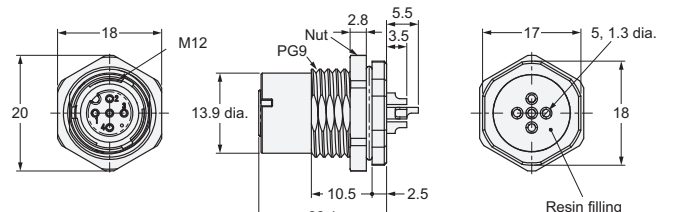

### Panel Cutout



Panel Cutout Dimension  
Panel thickness = 1 to 4 mm

Note 1. The panel cutout dimension is the same for Front Locking and Rear Locking Sockets.  
2. Rotational positioning is not possible for connector rotation.

For Signal (A-coding)

For Communication (D-coding)

For Power (L/S-coding)

Common Accessories

Common Precautions

# XS5M-D Panel-mounting Plugs

## Ordering Information

Type	No. of poles	Lock	Wire length (m)	Model	UL
With wire	4	Rear lock	0.5	XS5M-D426-5	UL2238 certified (File no. E207683)
		Front lock		XS5M-D427-5	
Type	No. of poles	Lock *	Applicable wires	Model	UL
Solder cup pins	4	Rear lock	AWG20 to AWG28	XS5M-D426-4	—
		Front lock		XS5M-D427-4	
	5	Rear lock		XS5M-D526-4	
		Front lock		XS5M-D527-4	

\*Install the rear lock type from the front of the panel and tighten the nut from the rear.  
Install the front lock type from the rear of the panel and tighten the nut from the front.

## Dimensions

(Unit: mm)

### With wire

#### Rear lock XS5M-D426-5

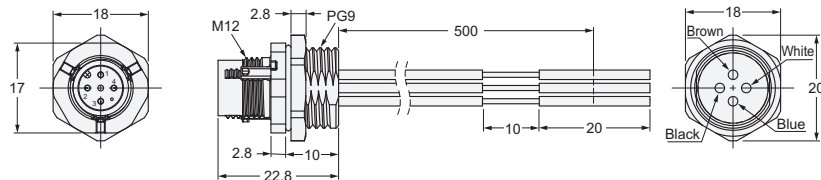

#### Wiring

Pin No.	Color
1	Brown
2	White
3	Blue
4	Black

#### Front lock XS5M-D427-5

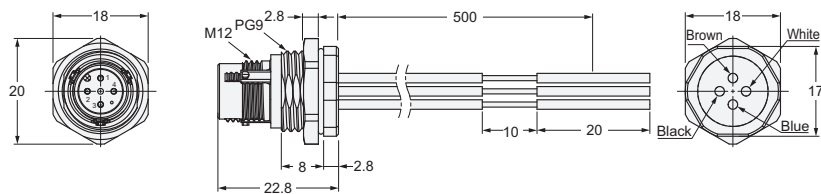

#### Wire Specifications

Specification	UL1007	
Nominal size	AWG20	
Configuration	Number of wires	21
	Wire diameter	0.18
	Standard outer diameter	1.8

### Solder cup pins

#### Rear lock XS5M-D426-4

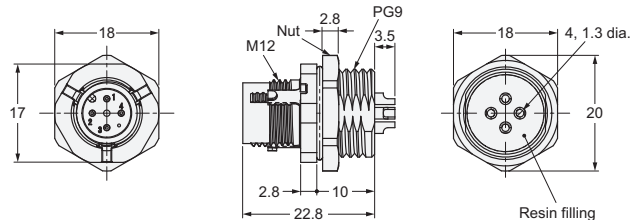

#### Rear lock XS5M-D526-4

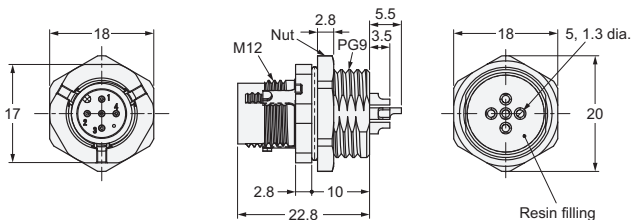

#### Front lock XS5M-D427-4

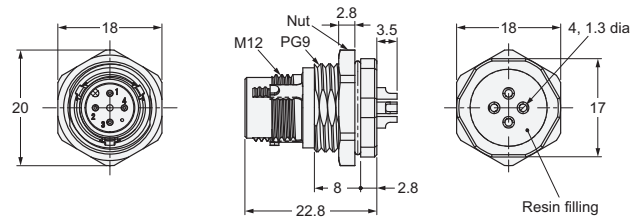

#### Front lock XS5M-D527-4

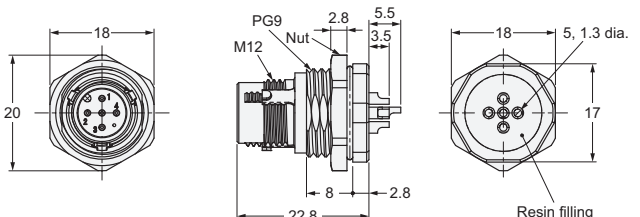

### Panel Cutout



Panel Cutout Dimension  
Panel thickness = 1 to 4 mm

- Note 1. The panel cutout dimension is the same for Front Locking and Rear Locking Sockets.  
2. Rotational positioning is not possible for connector rotation.

For Signal (A-coding)

For Communication (D-coding)

For Power (L/S-coding)

Common Accessories

Common Precautions

# XS5□-T (D-coding)

## Supports industrial Ethernet, including EtherNet/IP™ and EtherCAT®

- The M12 connector with excellent environmental resistance (IP67) adopts a Smart Click mechanism, enabling one-touch mating with approximately a 1/8 turn.
- The XS5W-T42□-□-K/KR/SS\* Series and XS6G-T421-1 are UL certified products.
- A lineup includes highly flexible cables suitable for use in cable carriers, as well as reinforced shielded types with excellent noise resistance.

\*Except for some models



For the most recent information on models that have been certified for safety standards, refer to your OMRON website.

## Ratings and Specifications

Item	Type	M12 connector cables	RJ45 (including RJ45/M12 Connector cable type)	M12 Connectors for Panel Mounting
	Model	XS5H-T42□-□M0-K XS5W-T42□-□M1-□□ XS5W-T42□-□M2-□□ XS5W-T42□-□M3-□□	XS5W-T42□-□MC-□□ XS5W-T421-□MC-SS XS5W-T42□-□MD-□□ XS5W-T42□-□ME-□□ XS6G-T421-1	XS5P-T42□-5 XS5P-T426-1
Rated current		3 A	2.5 A	4 A
Rated voltage *1		30 VDC		125 VDC
Contact resistance		40 mΩ max.		
Insulation resistance		1,000 MΩ min.	500 MΩ min.	1,000 MΩ min.
Withstand voltage		1,000 VAC for 60 s (leakage current: 1 mA max.)		1,500 VAC for 60 s (leakage current: 1 mA max.)
Ambient operating temperature		-25 to 70°C *2		
Ambient storage temperature		-25 to 70°C		
Protective structure		M12: IP67, RJ45: IP20 (IEC 60529)		

\*1. Voltage varies by installation environment.

\*2. Use robot cable within a temperature range of 0 to 70°C to avoid wire breakage when moving.

For Signal (A-coding)

For Communication (D-coding)

For Power (L/S-coding)

Common Accessories

Common Precautions

# Materials and Finish

## Connectors

Item	Type	M12		RJ45	
	Model	XS5H/W-T	XS5P-T42□-5	XS5P-T426-1	XS5W-T and XS6G
Contact blocks		PBT resin		PA resin	
Contacts		Copper alloy/Gold plating			
Anchors		Zinc alloy/Nickel plating			---
Anchors (tabs)		Stainless	---		
Shield		Stainless			
Cover		PBT resin	---		
O-rings		Rubber			---
Grounding fixture		---		Copper alloy/Tin plating	---
Anchor cover		---		Stainless	---
Nuts		---		Copper alloy/Nickel plating	---

## Cables

Item	Model	Standard Cable	Robot Cable	Shield Strengthening Model	
Compliant standard		UL CM			
Category		Cat5e			
Core/color		AWG22 (7/0.26): Yellow · Orange · White · Blue	AWG22 (7/24/0.05): Yellow · Orange · White · Blue	AWG22 (7/0.26): Yellow · Orange · White · Blue	
Outer diameter *1		6.5 dia.			
Sheath color *2		Light blue, Yellow		Black	
Sheath material		PVC			
Shield structure		Double shield			

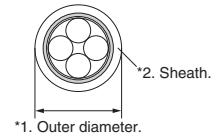

## Pin Arrangement (Engaged Side)

Item	No. of poles	4 poles
A-coding (DC type)	Male (plug) contacts	
	Female (socket) contacts	

For Signal (A-coding)

For Communication (D-coding)

For Power (L/S-coding)

Common Accessories

Common Precautions

# XS5W-T For Communication, Socket and Plug on Both Cable Ends

## Model Number Structure

### Model Number Legend

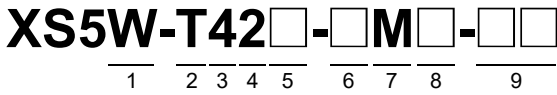

Use this model number legend to identify products from their model number.  
Use this model number legend to identify products from their model number. When ordering, use a model number from the table in *Ordering Information*.

- 1. Type**  
W: Connectors with cables, socket and plug on both cable ends
- 2. Mating Section Form**  
T: D-coding
- 3. Connector Poles**  
4: 4 poles
- 4. Contact Plating**  
2: Gold plating
- 5. Cable Connection Direction**  
1: Straight/straight  
2: Right-angle/right-angle
- 6. Cable Length**  
A: 0.3 m    B: 0.5 m    C: 1 m  
D: 2 m    E: 3 m    G: 5 m  
J: 10 m    K: 15 m
- 7. Connections (Numbers inside circles are terminal numbers)**  
M: ① Yellow, ② White, ③ Orange, ④ Blue
- 8. Connectors on One Cable End/Both Ends**  
1: Connectors on both ends: M12 socket/M12 plug  
2: Connectors on both ends: M12 plug/M12 plug  
3: Connectors on both ends: M12 socket/M12 socket  
C: Connectors on both ends: M12 plug/RJ45 plug  
D: Connectors on both ends: RJ45 plug/RJ45 plug  
E: Connectors on both ends: M12 socket/RJ45 plug
- 9. Cable Specifications**  
K: Standard cable (Cable color: Light blue)  
Y: Standard cable (Cable color: Yellow)  
KR: Robot cable (Cable color: Light blue)  
YR: Robot cable (Cable color: Yellow)  
SS: Shield Strengthening model  
(Standard cable, Cable color: Black)

## Ordering Information

### Standard cable, Robot cable (straight)

Type	Cable length L (m)	Standard cable/Blue	Standard cable/Yellow	Robot cable/Blue	Robot cable/Yellow
		Model	Model	Model	Model
M12 Plug-M12 Plug  Color ●●●●	0.5	XS5W-T421-BM2-K	XS5W-T421-BM2-Y	XS5W-T421-CM2-KR	XS5W-T421-CM2-YR
	1	XS5W-T421-CM2-K	XS5W-T421-CM2-Y	XS5W-T421-DM2-KR	XS5W-T421-DM2-YR
	2	XS5W-T421-DM2-K	XS5W-T421-DM2-Y	XS5W-T421-EM2-KR	XS5W-T421-EM2-YR
	3	XS5W-T421-EM2-K	XS5W-T421-EM2-Y	XS5W-T421-GM2-KR	XS5W-T421-GM2-YR
	5	XS5W-T421-GM2-K	XS5W-T421-GM2-Y	XS5W-T421-JM2-KR	---
	10	XS5W-T421-JM2-K	---	XS5W-T421-KM2-KR	---
	15	XS5W-T421-KM2-K	---	---	---
M12 Plug-RJ45  Color ●●●●	0.5	XS5W-T421-BMC-K	XS5W-T421-BMC-Y	XS5W-T421-BMC-KR	---
	1	XS5W-T421-CMC-K	XS5W-T421-CMC-Y	XS5W-T421-CMC-KR	---
	2	XS5W-T421-DMC-K	XS5W-T421-DMC-Y	XS5W-T421-DMC-KR	---
	3	XS5W-T421-EMC-K	XS5W-T421-EMC-Y	XS5W-T421-EMC-KR	XS5W-T421-EMC-YR
	5	XS5W-T421-GMC-K	XS5W-T421-GMC-Y	XS5W-T421-GMC-KR	XS5W-T421-GMC-YR
	10	XS5W-T421-JMC-K	---	XS5W-T421-JMC-KR	XS5W-T421-JMC-YR
	15	XS5W-T421-KMC-K	---	XS5W-T421-KMC-KR	XS5W-T421-KMC-YR
RJ45-RJ45  Color ●●●●	0.5	XS5W-T421-BMD-K	---	XS5W-T421-BMD-KR	XS5W-T421-BMD-YR
	1	XS5W-T421-CMD-K	---	XS5W-T421-CMD-KR	XS5W-T421-CMD-YR
	2	XS5W-T421-DMD-K	---	XS5W-T421-DMD-KR	XS5W-T421-DMD-YR
	3	XS5W-T421-EMD-K	---	XS5W-T421-EMD-KR	XS5W-T421-EMD-YR
	5	XS5W-T421-GMD-K	---	XS5W-T421-GMD-KR	XS5W-T421-GMD-YR
	10	XS5W-T421-JMD-K	---	XS5W-T421-JMD-KR	---
	15	XS5W-T421-KMD-K	---	XS5W-T421-KMD-KR	---



For Signal (A-coding)

For Communication (D-coding)



For Power (L/S-coding)

Common Accessories



Common Precautions

Type	Cable length L (m)	Standard cable/Blue	Robot cable/Blue
		Model	Model
M12 Plug-M12 Socket  Color ●	0.5	XS5W-T421-BM1-K	XS5W-T421-BM1-KR
	1	XS5W-T421-CM1-K	XS5W-T421-CM1-KR
	2	XS5W-T421-DM1-K	XS5W-T421-DM1-KR
	3	XS5W-T421-EM1-K	XS5W-T421-EM1-KR
	5	XS5W-T421-GM1-K	XS5W-T421-GM1-KR
	10	XS5W-T421-JM1-K	XS5W-T421-JM1-KR
	15	XS5W-T421-KM1-K	XS5W-T421-KM1-KR
M12 Socket-RJ45  Color ●	0.5	XS5W-T421-BME-K	---
	1	XS5W-T421-CME-K	---
	2	XS5W-T421-DME-K	---
	3	XS5W-T421-EME-K	---
	5	XS5W-T421-GME-K	---
	10	XS5W-T421-JME-K	---
	15	XS5W-T421-KME-K	---

Standard cable (Right-angle)

Type	Cable length L (m)	Model
M12 Plug Right angle- M12 Plug Right-angle  Color ●	0.3	XS5W-T422-AM2-K
	0.5	XS5W-T422-BM2-K
	1	XS5W-T422-CM2-K
	2	XS5W-T422-DM2-K
	3	XS5W-T422-EM2-K
	5	XS5W-T422-GM2-K
	10	XS5W-T422-JM2-K
M12 Plug Right angle- RJ45  Color ●	0.3	XS5W-T422-AMC-K
	0.5	XS5W-T422-BMC-K
	1	XS5W-T422-CMC-K
	2	XS5W-T422-DMC-K
	3	XS5W-T422-EMC-K
	5	XS5W-T422-GMC-K
	10	XS5W-T422-JMC-K
15	XS5W-T422-KMC-K	

Shield Strengthening model

Type	Cable length L (m)	Model
M12 Plug-M12 Plug  Color ●	0.5	XS5W-T421-BM2-SS
	1	XS5W-T421-CM2-SS
	2	XS5W-T421-DM2-SS
	3	XS5W-T421-EM2-SS
	5	XS5W-T421-GM2-SS
	10	XS5W-T421-JM2-SS
M12 Plug-RJ45  Color ●	0.5	XS5W-T421-BMC-SS
	1	XS5W-T421-CMC-SS
	2	XS5W-T421-DMC-SS
	3	XS5W-T421-EMC-SS
	10	XS5W-T421-JMC-SS

Dimensions

(Unit: mm)

M12 Smartclick Straight Plug/M12 Smartclick Straight Plug  
XS5W-T421-□M2-□□



Color ●●●●

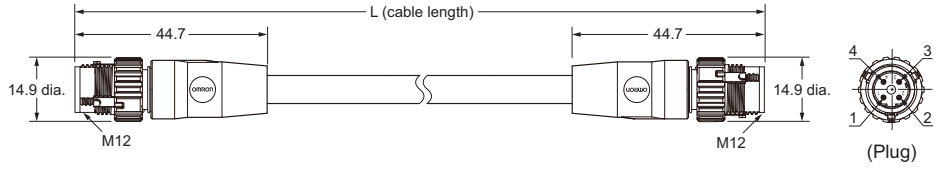
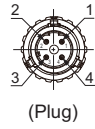

M12 Smartclick Straight Plug/RJ45  
XS5W-T421-□MC-□□



Color ●●●●

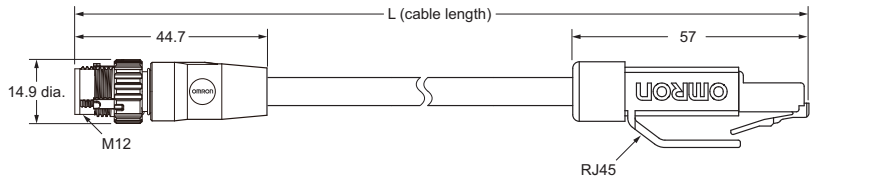
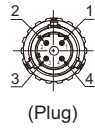

RJ45/RJ45  
XS5W-T421-□MD-□□



Color ●●●●

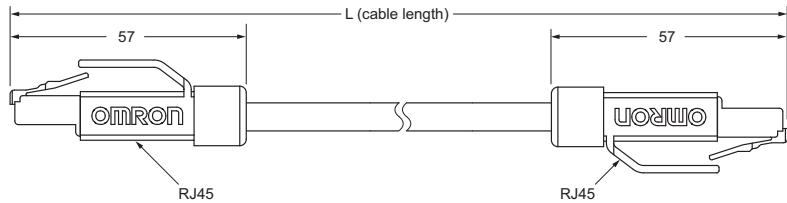

M12 Smartclick Straight Plug/M12 Smartclick Straight Socket  
XS5W-T421-□M1-□□



Color ●●●●

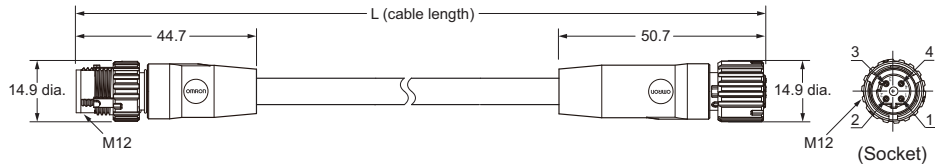

For Signal (A-coding)

For Communication (D-coding)

For Power (L/S-coding)

Common Accessories

Common Precautions

**M12 Smartclick Straight Socket/RJ45**  
XS5W-T421-□ME-K



Color ●

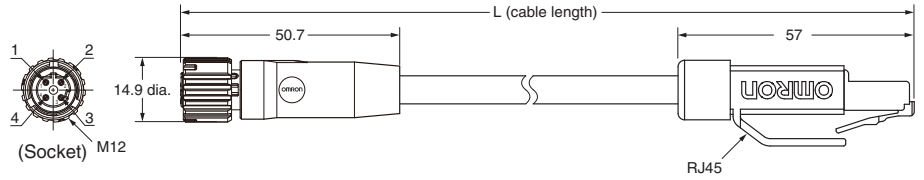

**Wiring**

M12 straight	RJ45
1	1
2	3
3	2
4	6
Shield	Shield

**M12 Smartclick Right-angle/M12 Smartclick Right-angle**  
XS5W-T422-□M2-K



Color ●

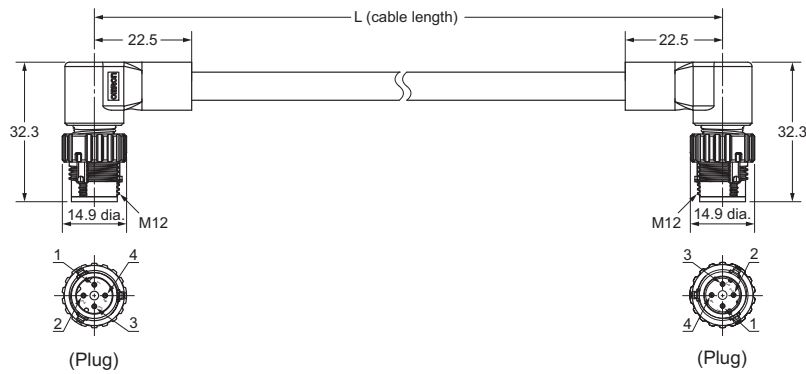

**Wiring**

M12 right angle	M12 right angle
1	1
2	2
3	3
4	4
Shield	Shield

**M12 Smartclick Right-angle Plug/RJ45**  
XS5W-T422-□MC-K



Color ●

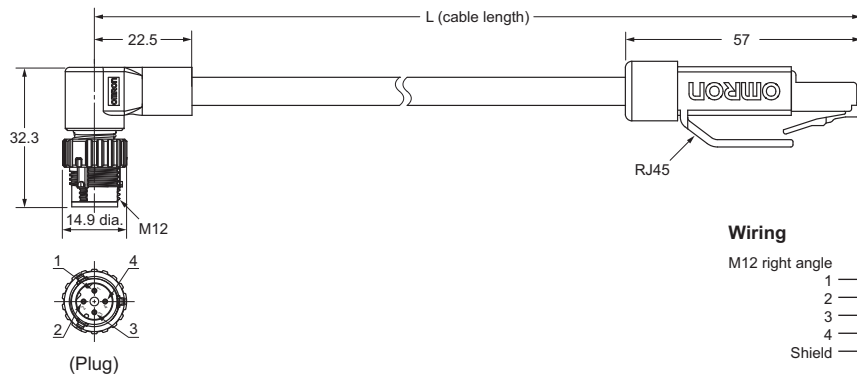

**Wiring**

M12 right angle	RJ45
1	1
2	3
3	2
4	6
Shield	Shield

For Signal (A-coding)

For Communication (D-coding)

For Power (L/S-coding)

Common Accessories

Common Precautions

# XS5H-T For Communication, Plug on One Cable End

## Model Number Structure

### Model Number Legend

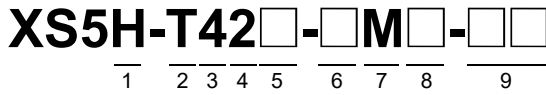

Use this model number legend to identify products from their model number.  
 Use this model number legend to identify products from their model number. When ordering, use a model number from the table in *Ordering Information*.

**1. Type**

H: Connectors with cables  
 Plug on one cable end

**2. Mating Section Form**

T: D-coding

**3. Connector Poles**

4: 4 poles

**4. Contact Plating**

2: Gold plating

**5. Cable Connection Direction**

1: Straight  
 2: Right-angle

**6. Cable Length**

B: 0.5 m   C: 1 m   D: 2 m  
 E: 3 m   G: 5 m   J: 10 m  
 K: 15 m

**7. Connections (Numbers inside circles are terminal numbers)**

M: ① Yellow, ② White,  
 ③ Orange, ④ Blue



**8. Connectors on One Cable End/ Both Ends**

0: One cable end

**9. Cable Specifications**

K: Standard cable  
 (Cable color: Light blue)

## Ordering Information

Type	Cable length L (m)	Model
Straight  Color ●	0.5	XS5H-T421-BM0-K
	1	XS5H-T421-CM0-K
	2	XS5H-T421-DM0-K
	3	XS5H-T421-EM0-K
	5	XS5H-T421-GM0-K
	10	XS5H-T421-JM0-K
	15	XS5H-T421-KM0-K
Right-angle  Color ●	0.5	XS5H-T422-BM0-K
	1	XS5H-T422-CM0-K
	2	XS5H-T422-DM0-K
	3	XS5H-T422-EM0-K
	5	XS5H-T422-GM0-K
	10	XS5H-T422-JM0-K
15	XS5H-T422-KM0-K	
RJ45 Assembly Connector 	---	XS6G-T421-1

For Signal (A-coding)

For Communication (D-coding)

For Power (L/S-coding)

Common Accessories

Common Precautions

(Unit: mm)

# Dimensions

## M12 Smartclick Straight Plug XS5H-T421-□M0-K

### Wiring

Terminal No.	Color	Signal
1	Yellow	TD+
2	White	RD+
3	Orange	TD-
4	Blue	RD-



Color ●

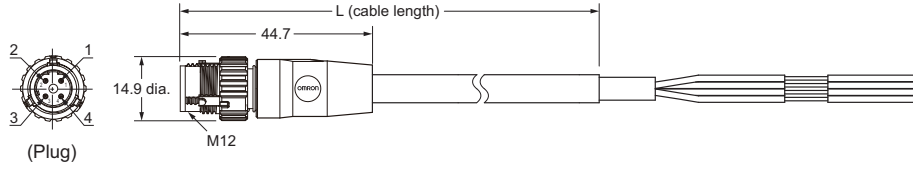

## M12 Smartclick Right-angle Plug XS5H-T422-□M0-K

### Wiring

Terminal No.	Color	Signal
1	Yellow	TD+
2	White	RD+
3	Orange	TD-
4	Blue	RD-



Color ●

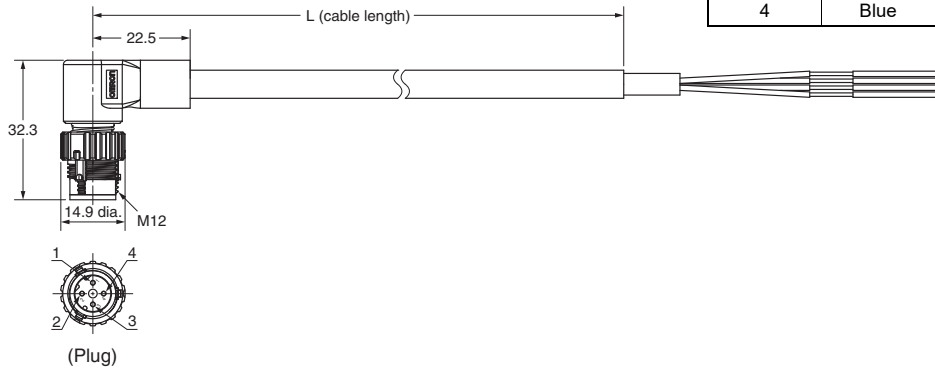

## RJ45 Assembly Connector XS6G-T421-1

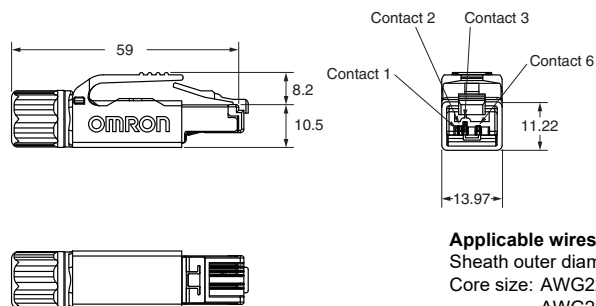

### Applicable wires

Sheath outer diameter: 4.5 to 9.0 mm  
Core size: AWG22 to AWG24 (stranded wires)  
AWG22 to AWG23 (solid wires)  
Insulation outer diameter: 1.6 mm max.

For Signal (A-coding)

For Communication (D-coding)

For Power (L/S-coding)

Common Accessories

Common Precautions

# XS5P-T Panel-mounting Sockets

## Ordering Information

Type	Lock	Wire length (m)	Model
With wire *	Rear Locking	0.5	XS5P-T426-5
	Rear Locking, with connector anti-rotation mechanism		XS5P-T428-5
	Front Locking		XS5P-T427-5
Type			Model
M12 Panel-mounting PCB Straight Terminals *			XS5P-T426-1

\*Install the rear lock type from the front of the panel and tighten the nut from the rear.  
Install the front lock type from the rear of the panel and tighten the nut from the front.

## Dimensions

(Unit: mm)

With wire  
XS5P-T42□-5



**XS5P-T426-5 (Rear Locking)**

**XS5P-T428-5 (Rear Locking, with connector anti-rotation mechanism)**

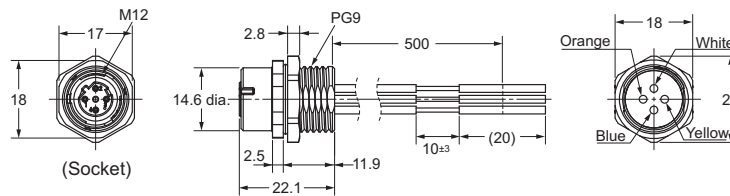

**XS5P-T427-5 (Front Locking)**

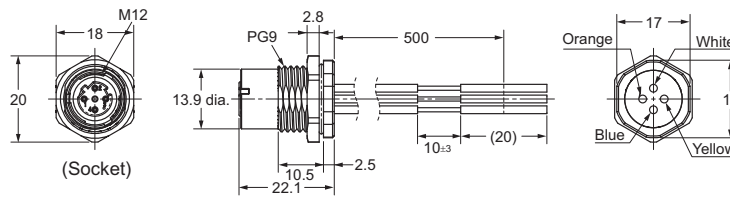

### Wiring

Terminal No.	Color	Signal
1	Yellow	TD+
2	White	RD+
3	Orange	TD-
4	Blue	RD-

### Panel Cutout Dimension

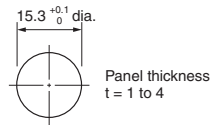

Note 1: The panel cutout dimension is the same for Front-locking and Rear-locking Connectors.

Note 2: Rotational positioning is not possible for connector rotation.

**M12 Panel-mounting PCB Straight Terminals**  
XS5P-T426-1

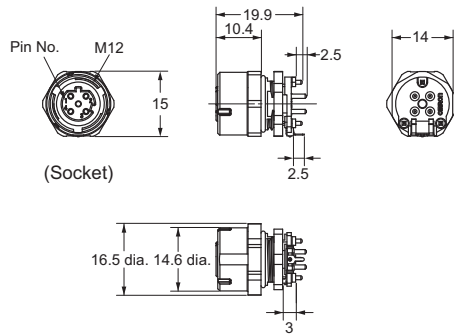

### Mounting Hole Dimensions (D Cut Structure)

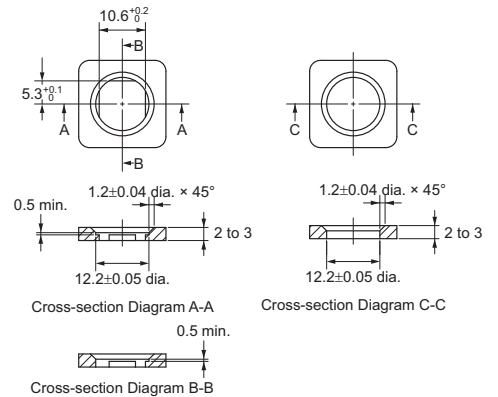

### Panel Processing Dimensions

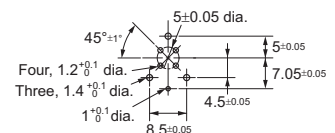

For Signal (A-coding)

For Communication (D-coding)

For Power (L/S-coding)

Common Accessories

Common Precautions

# XS5□-L/S (L-coding/S-coding)

**M12 connector supporting up to 630 VAC**  
**Smartclick technology combines compact size with high power output.**

- Connection completed with just a 1/8 turn. The Smartclick design reduces installation time.
- Compact size supports high current up to 12 A.
- Ideal for downsizing and replacement of conventional 7/8-inch connectors.



Available in July 2026

For the most recent information on models that have been certified for safety standards, refer to your OMRON website.

## Ratings and Specifications

Item	Model	XS5□-L	XS5□-S
Rated current		12 A	12 A
Rated voltage		63 VDC	600 VAC
Contact resistance (connector)		5 mΩ max.	5 mΩ max.
Insulation resistance		100 MΩ min. (at 500 VDC)	100 MΩ min. (at 500 VDC)
Dielectric strength (connector)		840 VAC for 1 min (leakage current: 2 mA max.)	3,310 VAC for 1 min (leakage current: 2 mA max.)
Insertion tolerance		50 times	50 times
Ambient operating temperature range		-25 to 85°C *1	-25 to 85°C
Ambient humidity range		20% to 85%	
Degree of protection		IP67 (IEC60529)	

Item	Model	XS5□-L	XS5□-S
Pin block		PBT resin	PBT resin
Contacts		Copper alloy/Gold plated	Copper alloy/Gold plated
Fixture		Nickel plated zinc alloy	Nickel plated zinc alloy
Fixtures (Lock)		Stainless	Stainless
O-ring		Rubber	Rubber
Cover		PBT resin	PBT resin
Cable		9.5 mm dia. AWG17 UL AWM2517 Sheath color: Black	9.6 mm dia. AWG16 UL TC-ER Sheath color: Black

\*1. Connector conversion cable: -25 to 70°C

### Pin Arrangement (Engaged Side)

Item	No. of poles	Mating structure
L-coding (DC type)	Male (plug) contacts	
	Female (socket) contacts	
S-coding (AC type)	Male (plug) contacts	
	Female (socket) contacts	

For Signal (A-coding)

For Communication (D-coding)

For Power (L/S-coding)

Common Accessories

Common Precautions

# XS5W-L/S For Power, Socket and Plug on Both Cable Ends

## Model Number Structure

### Model Number Legend

**XS5W-□□21-□□2-F**

1
2
3
4
5
6
7
8
9

Use this model number legend to identify products from their model number.  
 Use this model number legend to identify products from their model number. When ordering, use a model number from the table in *Ordering Information*.

- |   |   |   |
|---|---|---|
| <p><b>1. Type</b><br/>W: Connectors with cables, socket and plug on both cable ends</p> <p><b>2. Mating Section Form</b><br/>L: L-coding (DC type)<br/>S: S-coding (AC type)</p> <p><b>3. Connector Poles</b><br/>3: 3 poles<br/>5: 5 poles</p> | <p><b>4. Contact Plating</b><br/>2: Gold plating</p> <p><b>5. Cable Connection Direction</b><br/>1: Straight (Socket)/straight (Plug)</p> <p><b>6. Cable Length</b><br/>B: 0.5 m    C: 1 m    D: 2 m<br/>E: 3 m    G: 5 m    J: 10 m<br/>K: 15 m    L: 20 m</p> | <p><b>7. Connections (Numbers inside circles are terminal numbers)</b><br/>1: ① Brown, ② White, ③ Blue, ④ Black, Ⓣ Gray<br/>2: ① Black (1), ②-③ Black (2), Ⓣ Green/Yellow</p> <p><b>8. Rated current</b><br/>2: 12 A</p> <p><b>9. Cable Specifications</b><br/>F: PVC robot cable</p> |
|---|---|---|

## Ordering Information

Shape	Cable length L (m)	L-Coding (5 poles)	S-Coding (3 poles)
		Model	Model
Straight  	0.5	XS5W-L521-B12-F	XS5W-S321-B22-F
	1	XS5W-L521-C12-F	XS5W-S321-C22-F
	2	XS5W-L521-D12-F	XS5W-S321-D22-F
	3	XS5W-L521-E12-F	XS5W-S321-E22-F
	5	XS5W-L521-G12-F	XS5W-S321-G22-F
	10	XS5W-L521-J12-F	XS5W-S321-J22-F
	15	XS5W-L521-K12-F	XS5W-S321-K22-F
	20	XS5W-L521-L12-F	XS5W-S321-L22-F

## Dimensions

(Unit: mm)

### Straight/Straight XS5W-L521-□□2-F

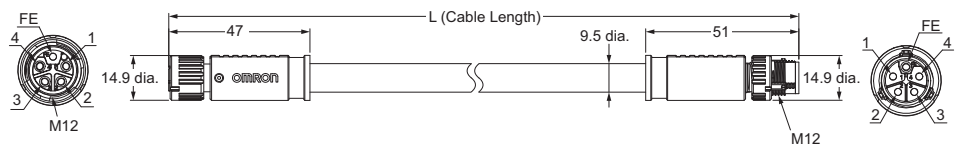

### Straight/Straight XS5W-S321-□□2-F

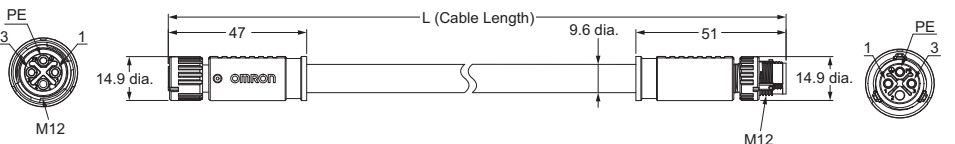

### Wiring diagram L-coding 5 cores

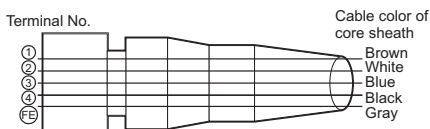

### S-coding 3 cores

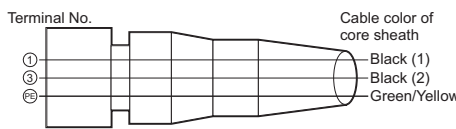

For Signal (A-coding)

For Communication (D-coding)

For Power (L/S-coding)

Common Accessories

Common Precautions

# XS5F-L/S For Power, Socket on One Cable End

## Model Number Structure

### Model Number Legend

**XS5F-□□21-□□2-F**

1
2
3
4
5
6
7
8
9

Use this model number legend to identify products from their model number.  
Use this model number legend to identify products from their model number. When ordering, use a model number from the table in *Ordering Information*.

- |  |   |   |
|--|---|---|
| <p><b>1. Type</b><br/>F: Connectors with cables, socket on one cable end</p> <p><b>2. Mating Section Form</b><br/>L: L-coding (DC type)<br/>S: S-coding (AC type)</p> <p><b>3. Connector Poles</b><br/>3: 3 poles<br/>5: 5 poles</p> | <p><b>4. Contact Plating</b><br/>2: Gold plating</p> <p><b>5. Cable Connection Direction</b><br/>1: Straight</p> <p><b>6. Cable Length</b><br/>B: 0.5 m   C: 1 m   D: 2 m<br/>E: 3 m   G: 5 m   J: 10 m<br/>K: 15 m   L: 20 m</p> | <p><b>7. Connections (Numbers inside circles are terminal numbers)</b><br/>1: ① Brown, ② White, ③ Blue, ④ Black, ⑤ Gray<br/>2: ① Black (1), ②-③ Black (2), ④ Green/Yellow</p> <p><b>8. Rated current</b><br/>2: 12 A</p> <p><b>9. Cable Specifications</b><br/>F: PVC robot cable</p> |
|--|---|---|

## Ordering Information

Shape	Cable length L (m)	L-Coding (5 poles)	S-Coding (3 poles)
		Model	Model
Straight  	0.5	XS5F-L521-B12-F	XS5F-S321-B22-F
	1	XS5F-L521-C12-F	XS5F-S321-C22-F
	2	XS5F-L521-D12-F	XS5F-S321-D22-F
	3	XS5F-L521-E12-F	XS5F-S321-E22-F
	5	XS5F-L521-G12-F	XS5F-S321-G22-F
	10	XS5F-L521-J12-F	XS5F-S321-J22-F
	15	XS5F-L521-K12-F	XS5F-S321-K22-F
	20	XS5F-L521-L12-F	XS5F-S321-L22-F

## Dimensions

(Unit: mm)

**Straight**  
XS5F-L521-□□2-F

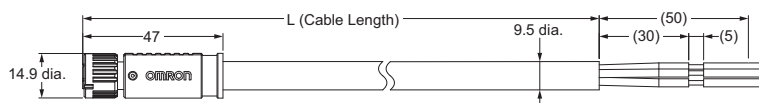

**Straight**  
XS5F-S321-□□2-F

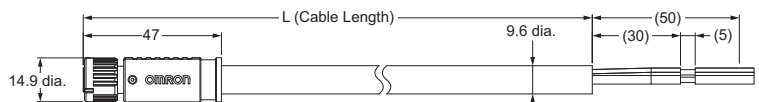
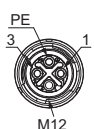

**Wiring diagram**  
L-coding 5 cores

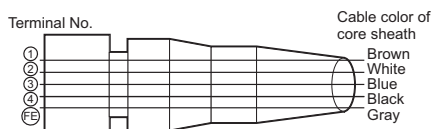

**S-coding 3 cores**

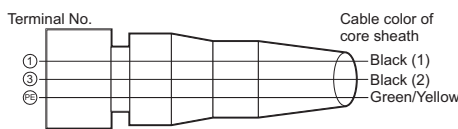

For Signal (A-coding)

For Communication (D-coding)

For Power (L/S-coding)

Common Accessories

Common Precautions

# XS5H-L For Power, Plug on One Cable End

## Model Number Structure

### Model Number Legend

**XS5H-□□21-□□2-F**

1
2
3
4
5
6
7
8
9

Use this model number legend to identify products from their model number.  
 Use this model number legend to identify products from their model number. When ordering, use a model number from the table in *Ordering Information*.

- |   |  |   |
|---|--|---|
| <p><b>1. Type</b><br/>H: Connectors with cables, Plug on one cable end</p> <p><b>2. Mating Section Form</b><br/>L: L-coding (DC type)</p> <p><b>3. Connector Poles</b><br/>5: 5 poles</p> | <p><b>4. Contact Plating</b><br/>2: Gold plating</p> <p><b>5. Cable Connection Direction</b><br/>1: Straight</p> <p><b>6. Cable Length</b><br/>B: 0.5 m    C: 1 m    D: 2 m<br/>E: 3 m    G: 5 m    J: 10 m<br/>K: 15 m    L: 20 m</p> | <p><b>7. Connections (Numbers inside circles are terminal numbers)</b><br/>1: ① Brown, ② White, ③ Blue, ④ Black, ⑤ Gray</p> <p><b>8. Rated current</b><br/>2: 12 A</p> <p><b>9. Cable Specifications</b><br/>F: PVC robot cable</p> |
|---|--|---|

## Ordering Information

Shape	Cable length L (m)	L-Coding (5 poles)
		Model
Straight  	0.5	<b>XS5H-L521-B12-F</b>
	1	<b>XS5H-L521-C12-F</b>
	2	<b>XS5H-L521-D12-F</b>
	3	<b>XS5H-L521-E12-F</b>
	5	<b>XS5H-L521-G12-F</b>
	10	<b>XS5H-L521-J12-F</b>
	15	<b>XS5H-L521-K12-F</b>
	20	<b>XS5H-L521-L12-F</b>

## Dimensions

(Unit: mm)

**Straight**  
XS5H-L521-□□2-F

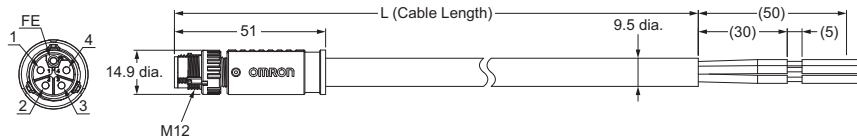

**Wiring diagram**  
L-coding 5 cores

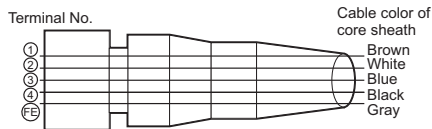

For Signal (A-coding)

For Communication (D-coding)

For Power (L/S-coding)

Common Accessories

Common Precautions

# Connector conversion cable for XS5W-L

## Ordering Information

Type		Cable length L (m)	Model
Plug/Upper	Socket/Lower		
7/8 4 poles	M12 L-coding	0.3	XS5W-L52A-A10-F
M12 L-coding	7/8 4 poles	0.3	XS5W-L52B-A10-F
7/8 5 poles	M12 L-coding	0.3	XS5W-L52C-A10-F
M12 L-coding	7/8 5 poles	0.3	XS5W-L52D-A10-F

## Dimensions

(Unit: mm)

### XS5W-L52A-A10-F

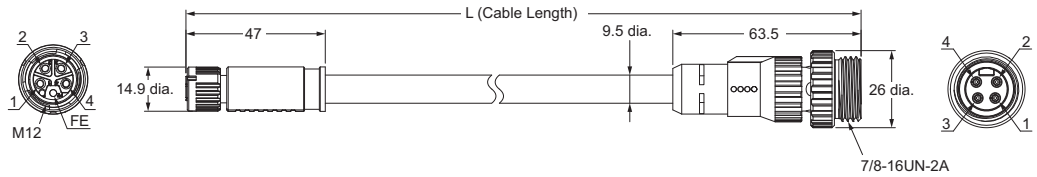

M12 L-Coding	7/8 4 poles
Socket/Lower	Plug/Upper
1	2
2	4
3	3
4	1
FE	---

### XS5W-L52B-A10-F

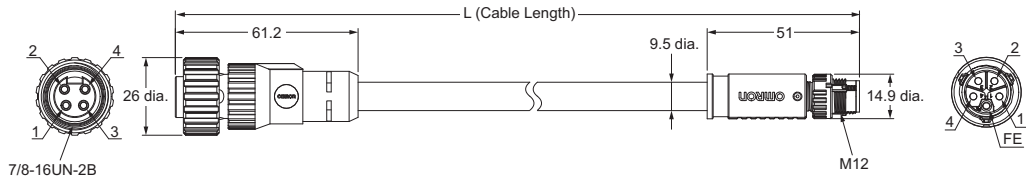

7/8 4 poles	M12 L-Coding
Socket/Lower	Plug/Upper
2	1
4	2
3	3
1	4
---	FE

### XS5W-L52C-A10-F

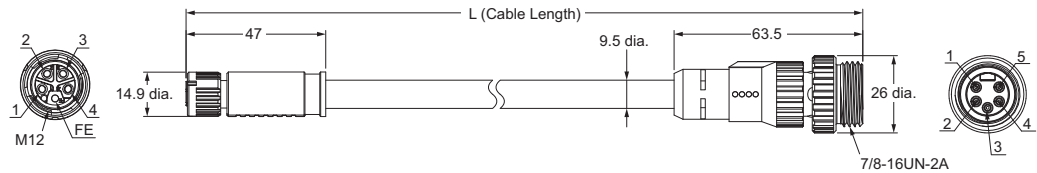

M12 L-Coding	7/8 5 poles
Socket/Lower	Plug/Upper
1	4
2	1
3	2
4	5
FE	3/FE

For Signal (A-coding)

For Communication (D-coding)

For Power (L/S-coding)

Common Accessories

Common Precautions

**XS5W-L52D-A10-F**

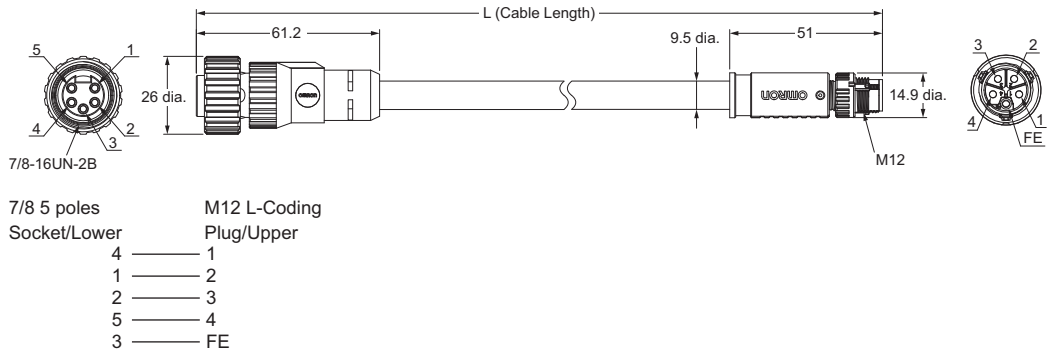

For Signal (A-coding)

For Communication (D-coding)

For Power (L/S-coding)

Common Accessories

Common Precautions

Common Accessories and Tools (Order Separately)

Ordering Information

Waterproof Caps

For Plug

XS5Z-13

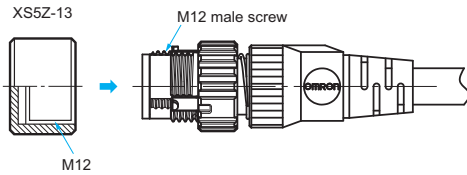

Application Example: XS5Z-13



For Socket

XS5Z-12

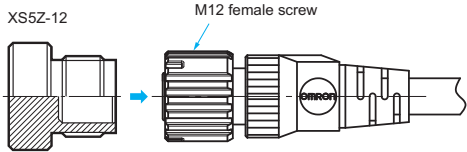
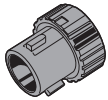

The Waterproof Cap ensures IP67. They have Smartclick mechanism. There's no need to keep track of locking torque.

Model	Material	Suitable connector	
		Model	Mounting portion
XS5Z-13	PBT	XS5W/XS5H/XS5G/XS5M/XS5R	M12 male screw
XS5Z-12	PBT	XS5W/XS5F/XS5C/XS5P/XS5R/XW3D	M12 female screw

Dust Covers

XS2Z-13

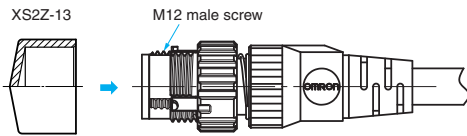

Application Example: XS2Z-13



XS2Z-15/XS2Z-14

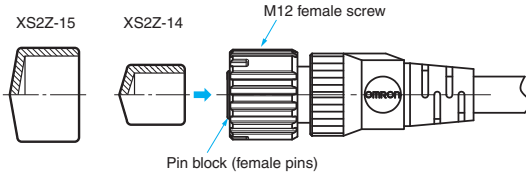

The Dust Cover is for dust prevention and does not ensure IP67 degree of protection. When mounting the Dust Cover to a Connector, be sure to press the Dust Cover onto the Connector until the Connector is fully inserted into the Dust Cover.

Model	Material	Suitable connector	
		Model	Mounting portion
XS2Z-13	Rubber/black	XS5G/XS5H/XS5M/XS5R/XS5W/XS2G/XS2H/XS2M/XS2R	M12 male screw
XS2Z-14		XS5C/XS5F/XS5P/XS5R/XS5W/XS2C/XS2F/XS2P/XS2R/XS2W/XW3B/XW3D	Pin block (female pins)
XS2Z-15			M12 female screw

Sputter Protective Cover

XS2Z-31

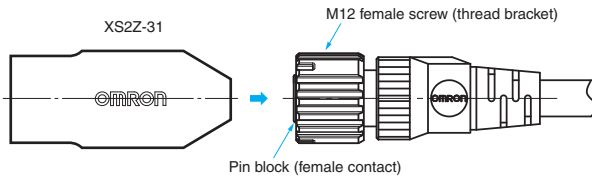
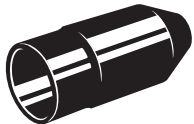

Application Example: XS2Z-31



The Sputter Protective Cover protects the connector from weld sputter. Make sure it covers the entire connector.

Model	Material	Suitable connector
XS2Z-31	Silicone rubber/black	XS5F/XS5H/XS5W/XS2F/XS2H/XS2W

For Signal (A-coding)

For Communication (D-coding)

For Power (L/S-coding)

Common Accessories

Common Precautions

**Tools**

**Crimp Tool**  
XY2F-0002

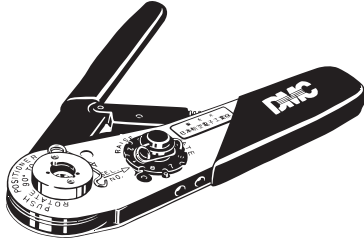

**Locator**  
XY2F-0003

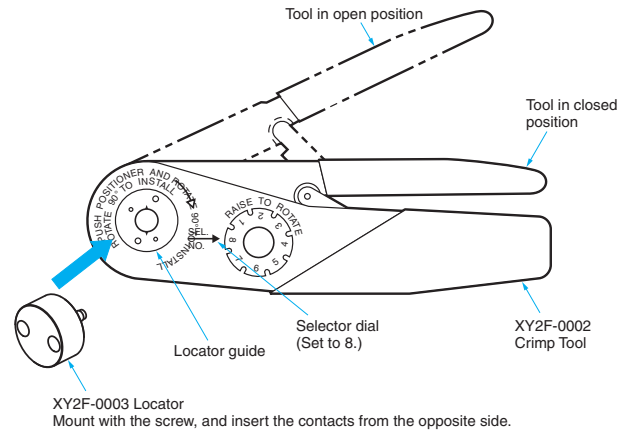

Use the Crimp Tool to crimp a cable core to the XS5U or XS2U Crimping Pin used with the XS□C or XS□G Crimping Connector. Both the Crimp Tool and the optional Locator are required for use.

- The XY2F-0002 Crimp Tool is DMC's AFM8 (M22520/2-01).
- The XY2F-0003 Locator is a component for positioning crimp terminals. Use the screw provided to mount the Locator to the locator guide of the Crimp Tool.

**Pin-block Extraction Tool**

XY2F-0001

Use this tool to extract a Pin Block from the covers in order to make wiring changes or corrections after the cover has been mounted to the pin block for Connector Assemblies (XS□C/ XS□G, soldering/crimping).

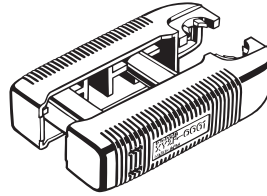

**Safety Precautions**

**Extraction Procedure**

(1) Disconnecting Components

- Disconnect all components on the cap side from the cover.

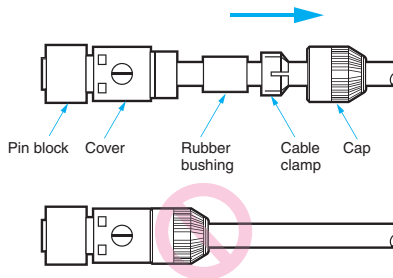

- Make sure that the pin block is outside the Tool.

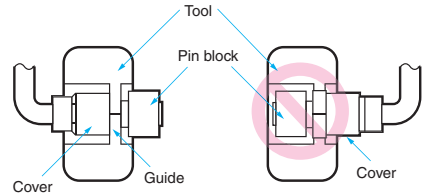

- Press the Tool so that the guides of the Tool are in close contact. Then pull the pin block straight.

(2) Extracting Pin Block

- Insert the claws of the Tool into the four holes of the cover.

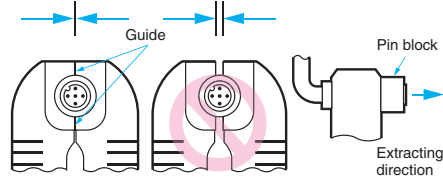
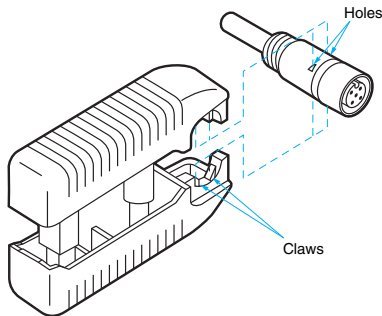

**Precautions for Correct Use**

- The pin block must not be extracted from the same Connector more than 3 times, otherwise the proper degree of protection of the pin block or Connector will not be maintained.

For Signal (A-coding)

For Communication (D-coding)

For Power (L/S-coding)

Common Accessories

Common Precautions

**XS5C/XS5G Safety Precautions**

**Assembly Procedure for XS5C/XS5G (IDC models) Connector Assemblies**

**(1) Preparations (Make sure they are all at hand.)**

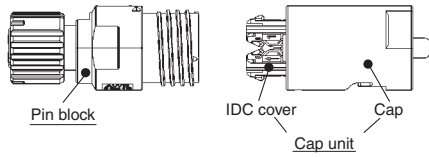

**(2) Dressing the cable end**

- Peel covering of a cable.

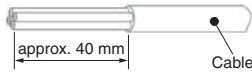

External diameter of applicable cable	Core conductor size
3 to 8 mm	0.14 to 0.75 mm <sup>2</sup> / AWG26 to 18

**(3) Choose the waterproof bushing**

- Choose the waterproof bushing type according to the cable size.

**External diameter of cable: In case of 3 to 5 mm**

Use the cap unit in the delivery state.

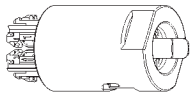

**External diameter of cable: In case of 5 to 8 mm**

When using, pick tab both sides of the waterproof bushing with a tab and pull it out in the direction of an arrow.

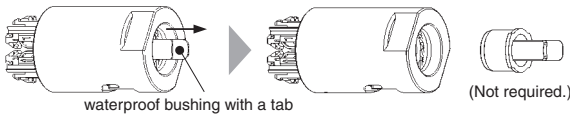

Note: When it isn't necessary to pull out bushing, do not pull a tab or pull out waterproof bushing carelessly. Do not insert the pulled-out bushing again.

**(4) Cable insertion**

- Insert a cable in the cap unit.

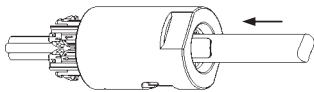

\*Insert fully until a cable doesn't enter any more.  
\*It's shown by a figure in case of cable diameter 3 to 5 mm.

**(5) Wiring**

- Confirm the terminal number indication\*1 of a IDC (Insulation Displacement Contact) cover, insert a core wire in each wire guide according to the terminal number and push in to the lowermost part of a core wire storage part.

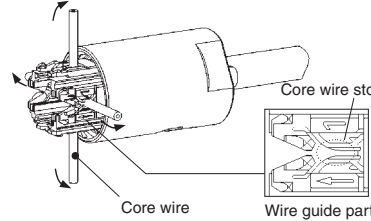

\*1. Terminal No.1: Brown  
Terminal No.2: White  
Terminal No.3: Blue  
Terminal No.4: Black

Note: There is a difference in a storing state depending on core wire diameter.

**(6) Processing the core wire end**

- Cut the end part of each core wire with nippers. Cutting the core wire end in the range of cut-area of figure.

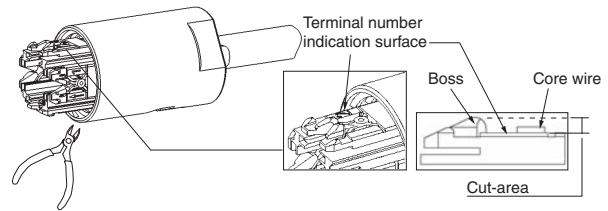

Note: Please be careful not to cut the boss.

**(7) Assembling the Pin block**

- Insert the cap unit core wire end processing has completed in a pin block.
- Use a △ mark of a housing and an arrow of a IDC cover, as a guideline of alignment. The location of the arrow is the side of the terminal No.1.

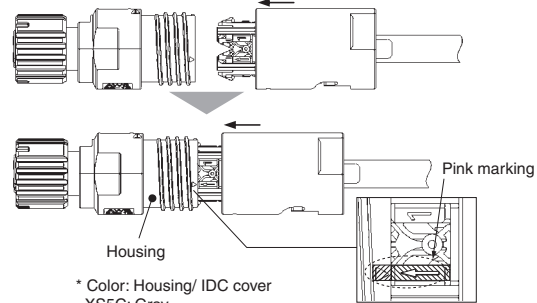

\* Color: Housing/ IDC cover  
XS5C: Gray  
XS5G: White

Note: Confirm that the color of the housing and the IDC cover is same before insertion.

For Signal (A-coding)

For Communication (D-coding)

For Power (L/S-coding)

Common Accessories

Common Precautions

**(8) Tightening up the cap**

- After inserting the cap unit and tightening a screw up lightly by hand, screw up the cap by a tool of a spanner or wrench (size 15 mm).<sup>2</sup>

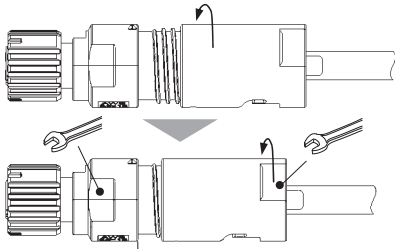

completion position ▲ \*2 When screwing up the cap by large size tool, it may cause damage.

- When a gap between a mold cover of pin block and a cap disappeared assembly and wire connection has completed.

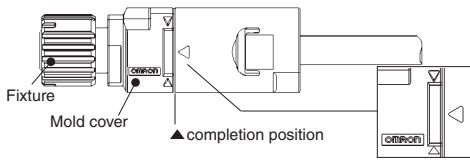

- Note 1. When the operation has completed, △ mark of cap comes into the square of the indicator formed into a mold cover (▷◁), so also use it as guideline to know to complete.
2. Avoid tightening a cap up beyond the completion position. It may cause damage.

**(9) Final checking**

- When the connector has been assembled, make sure the line insulation is as specified.

**Repair work procedure**

**Cap unit removal**

- When releasing wire connection, remove the cap unit in the opposite procedure of assembly work. [from (8) to (7)]

- Note 1. The core wire remain connected to the IDC connection part rarely. In that case, remove core wire end part to the vertical direction by tweezers etc.  
Do not touch the IDC contact directly at that time.
2. When IDC cover was left on the housing side, remove it by pulling a cable. In case IDC cover has been removed by holding strongly and pulling, it may cause damage.

**Cable removal**

- When removing the cable from the cap unit, pull the cable to the opposite direction of assembly work procedure (4). When tip of the core wire end has been pushed lightly into the IDC cover by tweezers etc, cable removal becomes easy.

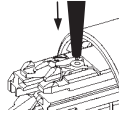

**Repair work**

- When connecting the wire again, do assembly (repair work) according to assembling procedure from (1) to (8).

- Note 1. In case of repair, use a cable of the same diameter and a core wire of the same diameter.  
The number of times of repair wire connection is maximum 10 times.
2. When doing a repair, work after enough removing the foreign substance and moisture adhering to a connector.  
Be careful so that the foreign substance and moisture do not enter the wire connection part.  
It may cause short-circuit etc.

For Signal (A-coding)

For Communication (D-coding)

For Power (L/S-coding)

Common Accessories

Common Precautions

**Assembly Procedure for XS5C/XS5G (Crimping/Soldering/Screw-on models) Connector Assemblies**

**(1) Connector and Cable Diameters**

- Connectors for 8, 7, 6, 4, and 3 mm diameter Cables (i.e., Cables that are 7 to 8, 6 to 7, 5 to 6, 4 to 5, and 3 to 4 mm in diameter respectively) are available.
- When assembling a Connector used with a cable, make sure that the external diameter of the Connector is suited to that of the cable.
- A waterproof bushing for 6/7 mm diameter Cable has no stripe, that for 8/4 mm diameter Cable has a single stripe, and that for 3 mm diameter Cable has two stripes.

**(2) Component Insertion**

**Crimping/Soldering Connectors**

**Straight Connectors**

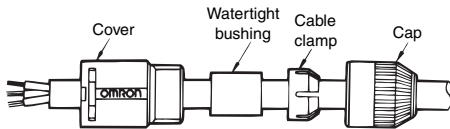

**(Right-angle Model)**

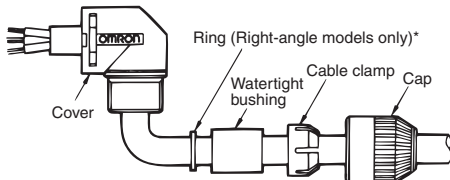

\*A ring is not required for Screw-on Connectors.

- As shown in the above illustration, connect the above components to the Cable with its end processed.

**Screw-on Connectors**

Confirm that you have all of the required parts.

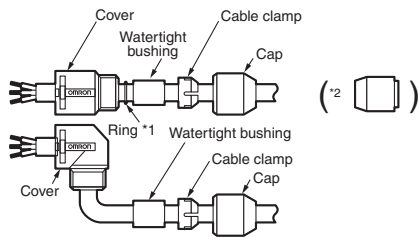

**Insulation caps and insulation tubes are included with 5-pole Connectors (XS5C-D5S□ and XS5G-D5S□).**

\*1. Rings are not required with 7-mm and 8-mm cables.  
 \*2. Insert the waterproof bushing for 7-mm and 8-mm cables in the direction shown in the diagram.

**(3) Wiring (Dressing the Cable Ends)**

**Soldering Connectors**

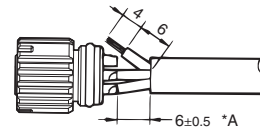

- Strip 10mm of the Cable sheath and 4 mm of each core.
- Before soldering cores and solder cup pins together, solder-coat each of them.
- The following conditions are recommended for soldering each solder cup pin.  
 Soldering temperature: 350±5°C  
 Soldering period: 3±1 s
- The length marked \*A should be 6.5 mm max., otherwise the proper degree of protection of the connector will not be maintained.

**Crimping Connectors**

**Crimping**

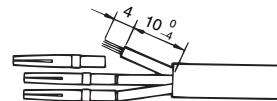

- Strip 14 mm of the Cable sheath and 4 mm of each core.
- Make sure that each core is not damaged and its end strands are not spread out.
- Mount the XY2F-0003 Locator to XY2F-0002 Crimp Tool, both of which are sold separately, and set the selector dial of the Crimp Tool to 8.
- After mounting the crimping pins to the Locator, fully insert the cores to the crimping pins.
- Squeeze the handle of the Crimp Tool to press-fit the cores to the crimping pins.  
 (Squeeze the handle firmly until the handle automatically returns to the release position.)

**Wiring**

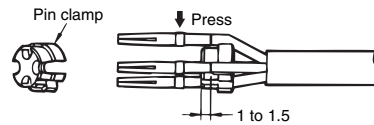

- After press-fitting the cores to the pins, insert the pins into the pin clamp as shown in the illustration. Then make sure that the lead colors correspond to the pin clamp numbers that are identical to the connector pin numbers.

**Insertion**

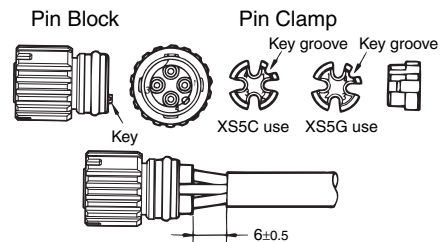

- Tentatively insert the pins to the pin block holes so that the key on the pin block will coincide with the key groove on the pin clamp. Then insert the cable along with the pin clamp.

For Signal (A-coding)

For Communication (D-coding)

For Power (L/S-coding)

Common Accessories

Common Precautions

**Screw-on Connectors**

**Dressing the Cable End**

**• Four-pole Connectors**

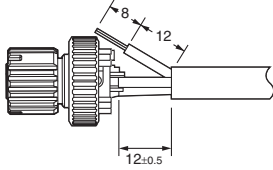

- Loosen the screws on pins 1 to 4 and insert the cores according to the pin numbers.

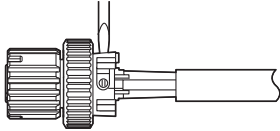

- Use the dedicated Screwdriver (XW4Z-00B)\* and tighten the screws securely so that the cores do not pull out. (0.15 to 0.2 N·m)

**• Five-pole Connectors**

- Strip the cable sheath for a total of 15 mm and strip the core covering for 8 mm for the core to connect to pin 5.

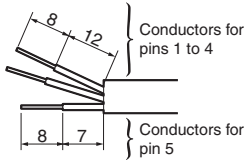

- Connect the core to pin 5 (in the center) first.
- Insert the core from the side of the hold with the tab and tighten the screw securely (tightening torque: Pins 1 to 4: 0.15 to 0.2 N·m, Pin 5: 0.03 to 0.05 N·m), and then cut off the excess wire with wire cutters.

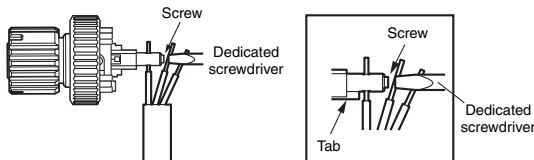

- Bend the cable as shown below, attached the enclosed insulation cap, and then strip the other cores.

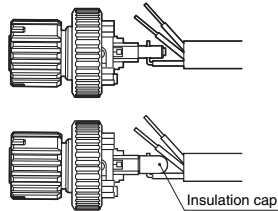

- Connect the cores to pins 1 to 4.

**Connecting Shielded Cables to Five-pole Connectors**

- Place the insulation tub on the drain line of the shield and connect it to the terminal.
- Tighten the screw and then check visually to see if there is insulation between the cores.

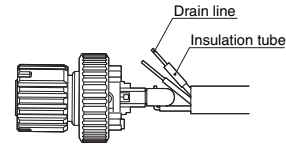

\*When tightening the screws, use the dedicated XW4Z-00B Screwdriver that matches with the screw-slot dimensions.



**Screwdriver  
XW4Z-00B**

**(4) Inserting Pin Block**

**Pin block  
(Soldering Model)**

**Cover  
(Straight Model)**

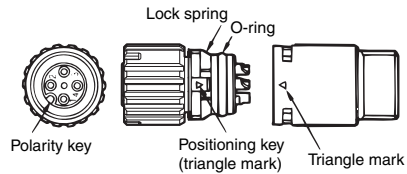

**(Crimping Model)**

**(Right-angle Model)**

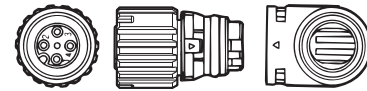

- Mount the cover to the pin block so that the triangle mark on the pin block will coincide with the triangle mark on the cover.
- If the cover is used for a Right-angle model, the relationship between the position of the polarity key on the engaged side and cable connection direction will be determined by the direction in which the positioning key is inserted into the cover, which can be rotated by 90°.
- Fully insert the positioning key until the positioning key is hidden by the casing.

**Pin block  
(Screw-on Connectors)**

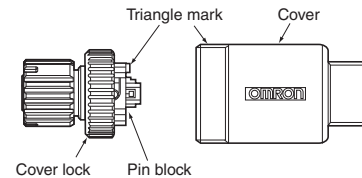

- Align the triangular marks on the pin block and cover and insert the pin block into the cover.
- Press them together firmly until the pin block does not come out of the cover. (0.39 to 0.49 N·m)

For Signal (A-coding)

For Communication (D-coding)

For Power (L/S-coding)

Common Accessories

Common Precautions

**(5) Mounting Cap**

- After mounting the cover to the pin block and the cover snaps into place, tighten the cap securely by hand (0.39 to 0.49 N·m)

Note: If the cap is not tighten securely enough, the degree of protection (IP67) may not be maintained or vibration may cause the cap to become loose. Do not tighten the cap with pliers or similar tools; they may damage the cap.

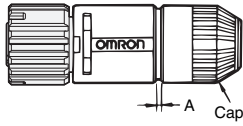

- After fully tightening the cap, length A should be approximately one of the following according to the cable external diameter and the Connector model. (Use these as a guide.)

External diameter of applicable cable	Cable external diameter (mm)			
	6 mm	5 mm	4 mm	3 mm
For 6-mm-dia. cable	1	0	—	—
For 4-mm-dia. cable	—	2	1	—
For 3-mm-dia. cable	—	—	2	1

**(6) After Assembly**

- Confirm the insulation between cores after completing assembly.

**Recommended Cables**

When connecting a commercially available cable to a connector assembly, use a cable with an outside diameter of 3 to 6 mm and core conductor sizes of 0.18 to 0.75 mm<sup>2</sup> for crimping connectors and 0.5 mm<sup>2</sup> maximum for soldering connectors.

**Connector Arrangement**

For safety, when constructing a connection system between a Sensor and panel with a connector, make sure that the connector plug is on the Sensor side and the connector socket is on the panel side (i.e., the female pins are located on the power-supply side).

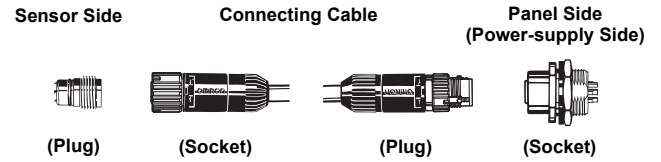

For Signal (A-coding)

For Communication (D-coding)

For Power (L/S-coding)

Common Accessories

Common Precautions

## Safety Precautions

### Definitions of Precautions

<b>Precautions for Safe Use</b>	These refer to actions that should be performed or refrained from in order to ensure safe product usage.
<b>Precautions for Correct Use</b>	These refer to actions that should be performed or refrained from in order to prevent product breakage, malfunctioning, and negative effects to performance and functionality.

### Precautions for Safe Use

#### Degree of Protection

Do not use these products if their protective structures have deteriorated, such as swelling or breakage of housing and sealing components.

If products with deteriorated protective structures continue to be used, breakage or fire damage, etc., may occur.

#### Connector Connection and Disconnection

- When connecting or disconnecting Connectors, be sure to hold the Connectors by hand.
- Do not hold the cable when disconnecting Connectors. Use after confirming the direction of the polarity key groove.
- Do not touch wiring with wet hands. Doing so may result in malfunction or breakage when the device is turned on.
- When mating Connectors, be sure to insert the plug all the way to the back of the socket before attempting to lock the Connectors. After operating the lock, always confirm that the Connector is connected.
- Do not use tools of any sort to mate the Connectors. Always use your hands. Pliers or other tools may damage the Connectors.
- When replacing the Connector, confirm that no foreign substances such as liquids or cutting oils are adhered to the connection surface of the Connector before connecting.
- When mating the Connectors to XS2 or other M12 Connectors, tighten the thread bracket by hand to a torque of 0.39 to 0.49 N·m.

### Precautions for Correct Use

- Do not use the Connectors in an atmosphere or environment that exceeds the specifications.
- Do not perform wiring while power is flowing. Doing so may result in electrical shock or device breakage.
- Do not use the Connectors in an environment where corrosive gases or high temperature/high humidity are present. Doing so may result in malfunctions such as connection/contact failures and corrosion.
- Do not pull excessively on the Connectors or cables.
- Do not step on or place any objects on the Connectors. Doing so may damage the Connectors.
- Install the Connectors in a location where they will not be stepped on, to prevent disconnection of the cables or damage to the Connectors. If the Connectors or cables must be installed where they might be stepped on, protect them with covers.
- If sensors or switches are not attached during installation, or if plug connectors are not connected, protect the mating surface of the Connector with a XS5Z-12, XS5Z-13, or XS2Z-11 Waterproof Cover or XS2Z-13/14/15 Dust Cover.

### Wiring

- Do not perform wiring in environments where the cable ends may be exposed to liquids such as water or cutting oils.
- Follow the wiring diagrams when wiring the cables. When using Sensors or Limit Switches, confirm whether connections are possible.
- Lay the cables so that external force is not applied to the Connectors. Otherwise, the degree of protection may not be achieved.

#### Degree of Protection (IP67)

- The degree of protection of Connectors (IP67) is not for a fully watertight structure. Do not use the Connectors underwater.

#### Setup

- Do not install the Connectors or cables in any way that would place a load directly on the mating section or cable connections. Doing so can damage the Connectors or break the wires inside the cables.
  - Any bends made must have a minimum radius of 40 mm \*.
- \*When using the XS5-S series (Fire-retardant, thin PVC robot cable with 4 dia.), bending radius must have 30mm or longer. When using L-coding or S-coding, ensure that the bending radius is 60 mm or more.

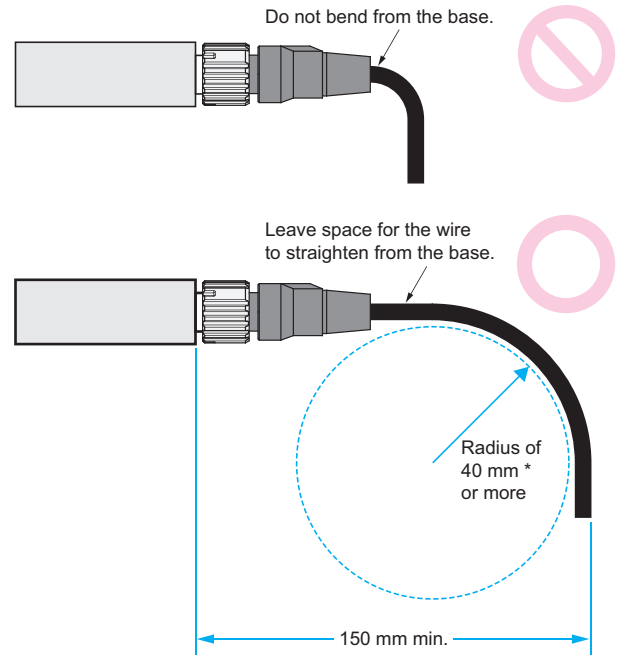

- Do not install the connector parts in close contact. There is a risk of high temperatures.

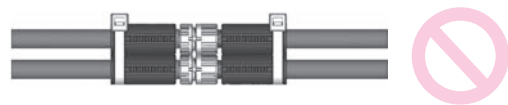

### Storage

When storing the product for an extended period, observe the following precautions:

1. Store the product in a location that is protected from dust and moisture.
2. Do not store the product near sources of gas generation, such as ammonia gas or sulfurous gas.

## Connector Connection Procedure

### 1. Connecting the XS5 Plug and Socket

- Align the projection on the plug cover with the polarity key on the socket, then insert the plug all the way in.

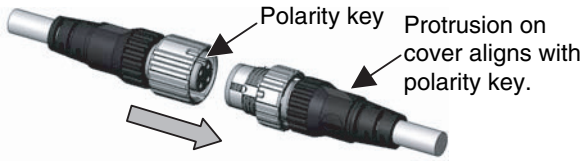

- Hold the knurled socket grip, then insert the projection on the plug into the groove of the socket.



- Turn the knurled grips of the socket clockwise approximately 45 degrees in respect to the plug. A click will indicate that the Connectors are locked. The locking condition can also be confirmed by the alignment marks on the plug and socket.

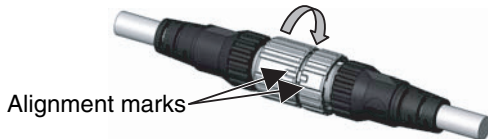

### 2. Connecting the XS5 and XS2

- Align the projection on the plug cover with the polarity key on the socket, then insert the plug all the way in.
- In the same way as when connecting two XS2 Connectors, screw the knurled grip in the clockwise direction.
- Use your fingers to tighten the Connectors sufficiently.

For Signal (A-coding)

For Communication (D-coding)

For Power (L/S-coding)

Common Accessories

Common Precautions

Smartclick is a trademark or registered trademark of OMRON Corporation in Japan and other countries.

Systemac is a trademark or registered trademark of OMRON Corporation in Japan and other countries for OMRON factory automation products.

EtherCAT® is a registered trademark of Beckhoff Automation GmbH for their patented technology.

EtherNet/IP™ and DeviceNet™ are trademarks of ODVA.

## Terms and Conditions Agreement

### Read and understand this catalog.

Please read and understand this catalog before purchasing the products. Please consult your OMRON representative if you have any questions or comments.

### Warranties.

(a) Exclusive Warranty. Omron's exclusive warranty is that the Products will be free from defects in materials and workmanship for a period of twelve months from the date of sale by Omron (or such other period expressed in writing by Omron). Omron disclaims all other warranties, express or implied.

(b) Limitations. OMRON MAKES NO WARRANTY OR REPRESENTATION, EXPRESS OR IMPLIED, ABOUT NON-INFRINGEMENT, MERCHANTABILITY OR FITNESS FOR A PARTICULAR PURPOSE OF THE PRODUCTS. BUYER ACKNOWLEDGES THAT IT ALONE HAS DETERMINED THAT THE PRODUCTS WILL SUITABLY MEET THE REQUIREMENTS OF THEIR INTENDED USE.

Omron further disclaims all warranties and responsibility of any type for claims or expenses based on infringement by the Products or otherwise of any intellectual property right. (c) Buyer Remedy. Omron's sole obligation hereunder shall be, at Omron's election, to (i) replace (in the form originally shipped with Buyer responsible for labor charges for removal or replacement thereof) the non-complying Product, (ii) repair the non-complying Product, or (iii) repay or credit Buyer an amount equal to the purchase price of the non-complying Product; provided that in no event shall Omron be responsible for warranty, repair, indemnity or any other claims or expenses regarding the Products unless Omron's analysis confirms that the Products were properly handled, stored, installed and maintained and not subject to contamination, abuse, misuse or inappropriate modification. Return of any Products by Buyer must be approved in writing by Omron before shipment. Omron Companies shall not be liable for the suitability or unsuitability or the results from the use of Products in combination with any electrical or electronic components, circuits, system assemblies or any other materials or substances or environments. Any advice, recommendations or information given orally or in writing, are not to be construed as an amendment or addition to the above warranty.

See <http://www.omron.com/global/> or contact your Omron representative for published information.

### Limitation on Liability; Etc.

OMRON COMPANIES SHALL NOT BE LIABLE FOR SPECIAL, INDIRECT, INCIDENTAL, OR CONSEQUENTIAL DAMAGES, LOSS OF PROFITS OR PRODUCTION OR COMMERCIAL LOSS IN ANY WAY CONNECTED WITH THE PRODUCTS, WHETHER SUCH CLAIM IS BASED IN CONTRACT, WARRANTY, NEGLIGENCE OR STRICT LIABILITY.

Further, in no event shall liability of Omron Companies exceed the individual price of the Product on which liability is asserted.

### Suitability of Use.

Omron Companies shall not be responsible for conformity with any standards, codes or regulations which apply to the combination of the Product in the Buyer's application or use of the Product. At Buyer's request, Omron will provide applicable third party certification documents identifying ratings and limitations of use which apply to the Product. This information by itself is not sufficient for a complete determination of the suitability of the Product in combination with the end product, machine, system, or other application or use. Buyer shall be solely responsible for determining appropriateness of the particular Product with respect to Buyer's application, product or system. Buyer shall take application responsibility in all cases.

NEVER USE THE PRODUCT FOR AN APPLICATION INVOLVING SERIOUS RISK TO LIFE OR PROPERTY OR IN LARGE QUANTITIES WITHOUT ENSURING THAT THE SYSTEM AS A WHOLE HAS BEEN DESIGNED TO ADDRESS THE RISKS, AND THAT THE OMRON PRODUCT(S) IS PROPERLY RATED AND INSTALLED FOR THE INTENDED USE WITHIN THE OVERALL EQUIPMENT OR SYSTEM.

### Programmable Products.

Omron Companies shall not be responsible for the user's programming of a programmable Product, or any consequence thereof.

### Performance Data.

Data presented in Omron Company websites, catalogs and other materials is provided as a guide for the user in determining suitability and does not constitute a warranty. It may represent the result of Omron's test conditions, and the user must correlate it to actual application requirements. Actual performance is subject to the Omron's Warranty and Limitations of Liability.

### Change in Specifications.

Product specifications and accessories may be changed at any time based on improvements and other reasons. It is our practice to change part numbers when published ratings or features are changed, or when significant construction changes are made. However, some specifications of the Product may be changed without any notice. When in doubt, special part numbers may be assigned to fix or establish key specifications for your application. Please consult with your Omron's representative at any time to confirm actual specifications of purchased Product.

### Errors and Omissions.

Information presented by Omron Companies has been checked and is believed to be accurate; however, no responsibility is assumed for clerical, typographical or proofreading errors or omissions.