

On-Panel Power Monitor

model **KM-N3-FLK**

Users Manual

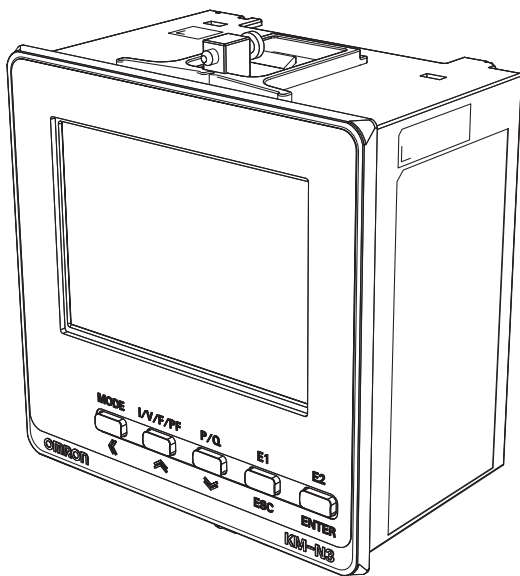

Thank you for purchasing the On-panel Power Monitor, model KM-N3-FLK (referred to as model KM-N3 in this manual).

This Users Manual describes the functions, performance, and application methods needed for optimum use of the unit.

Please observe the following when using this unit.

- This product is designed for use by qualified personnel with a knowledge of electrical systems.
- Before using the product, thoroughly read and understand this Users Manual to ensure correct use.
- Keep this Users Manual in a safe location so that it is available for reference whenever required.

1. Overview of the unit

2. Installation and wiring

3. Basic use

4. Settings needed to measure electricity

5. Other Functions

6. Detailed settings for communications

7. Troubleshooting

8. Appendices

Index

Agreement regarding use	4
Safety precautions	6
Important safety points	8
Precautions for correct use	9
Manual revision history	11

1. Overview of the unit

1.1 Main features	12
1.2 Device configuration	13
1.3 Names of the parts and their functions	14
1.4 Dimensions	18
1.5 Multi-circuit metering	20
1.6 Multi-address system	22
1.7 Mode configuration	23

2. Installation and wiring

2.1 Attaching the body of the unit	24
2.2 Wiring the CTs	26
2.3 Wiring the power supply	28
2.4 Wiring the measured voltage input	29
2.5 Fitting the CTs to the measuring wires	31
2.6 Pulse output wiring	32
2.7 RS-485 wiring	36
2.8 Wiring diagrams	38

3. Basic use

3.1 Turning the power on	41
3.2 Switching between modes	42
3.3 How to read the measurements	44
3.4 How to read the setting values	47

Index (continued)

4. Settings needed to measure electricity

4.1 Setting items for measuring electricity	51
4.2 Circuit settings	52
4.3 RS-485 communication settings	57
4.4 Pulse output settings	60

5. Other Functions

5.1 Voltage assignment.....	61
5.2 Measuring high voltage	62
5.3 Display unit conversion	63
5.4 Automatic LCD OFF	64
5.5 Alarm display with negative effective power value.....	65
5.6 Tariff feature.....	66
5.7 Change password.....	67
5.8 Checking software version.....	68
5.9 Initialize	69
5.10 Restart	71

6. Detailed settings for communications

6.1 Overview of communications.....	72
6.2 Modbus.....	73
6.3 CompoWay/F.....	82
6.4 Address map.....	96

7. Troubleshooting

7.1 Warnings	100
7.2 Troubleshooting	101

8. Appendices

8.1 Specifications	104
8.2 ASCII code table	107
8.3 14 segment displays and 7 segment displays.....	109

Agreement regarding use

Unless otherwise specifically agreed, you agree that the conditions in this agreement apply to your use of this Omron product, irrespective of the place of purchase.

1. Definitions

This defines some terms used in this agreement.

- (1) Omron products: FA system equipment, general-purpose control devices, sensors, and electronic/mechanical components under Omron brand.
- (2) Catalogs: Omron catalogues, including, without limitation, Omron "Best" Control Equipment Catalog, and General Catalog for Electronic/Mechanical Components, specifications, instructions and user manuals for Omron Products, whether or not provided electronically.
- (3) Usage Conditions: Usage conditions, rating, performance, operating environment, handling instructions, warnings, restrictions on use, etc. of Omron Products described in the Catalogs.
- (4) Customer Application: Any application of Omron Products by a customer to include, but are not limited to, embedding and/or using Omron Products in their parts/components, electronic substrates, devices, equipment or systems manufactured by customers.
- (5) Fitness: (a) fitness for a particular purpose, (b) performance, (c) non-infringement of third-party intellectual property, (d) compliance with laws and regulations and (e) conformity to standards of an Omron Product in the Customer Application.

2. Cautions regarding content

Be aware of the following points with regard to the content of Catalogs.

- (1) Rated values and performance values are based on stand-alone tests using each separate condition, and Omron does NOT warrant any rated values and performance values for multiple composite conditions.
- (2) Reference data is provided for your reference only. Omron does NOT warrant that Omron Products work properly at all times as provided in the reference data.
- (3) Application examples are provided for your reference only. Omron does NOT warrant the Fitness of Omron Products under such application.
- (4) Omron may discontinue the production of Omron Products or change their specifications for the purpose of improving such products or for other reasons entirely at its own discretion.

3. Precautions

You are deemed to accept the following terms when you adopt or use Omron Products:

- (1) Use Omron Products in compliance with Usage Conditions including rating and performance.
- (2) Confirm Fitness of Omron Products in Customer Application and use your own judgment to determine the appropriateness of using them in such application. Omron does NOT warrant the Fitness of Omron Products in Customer Application.
- (3) Confirm beforehand that Omron Products are properly wired and installed for their intended use in your overall system.
- (4) When using Omron Products, make sure to (i) maintain a margin of safety in relation to the published rated and performance values, such as introducing redundancy, (ii) design to minimize risks to any Customer Application in case of failure of any Omron Products, (iii) adopt system-wide safety measures to notify risks to users, and (iv) conduct regular maintenance on Omron Products and Customer Application.
- (5) Omron Products are designed and manufactured as general-purpose products for use in general industrial products. They are not intended to be used in the applications described below, therefore if you use Omron products in these applications, Omron provides no warranty for Omron products. However, this excepts cases where the use is a special use intended by Omron or where Omron has specifically agreed, even when used in the following applications.
 - (a) Applications with stringent safety requirements (For example, nuclear power control equipment, combustion equipment, aerospace equipment, railway equipment, elevator and lift equipment, amusement equipment, medical equipment, safety equipment, and other applications that could cause physical injury or result in the loss of life.)
 - (b) Applications that require high reliability (For example, supply systems for gas, water and electricity, etc., 24 hour continuous operating systems, financial settlement systems and other applications that handle rights and property.)

Agreement regarding use(continued)

- (c) Applications under severe conditions or in severe environments (For example, outdoor equipment, equipment exposed to chemical contamination, equipment exposed to electromagnetic interference and equipment exposed to vibration and shocks.)
- (d) Applications under conditions or environments not described in catalogs or other publications.
- (6) In addition to the applications listed in 3.(5) (a) to (d), the products in this publication are not intended for use in automobiles (including for two-wheeled vehicles, and this description applies hereafter). Do not use for applications involving fitting to automobiles. Consult Omron staff for information about products suitable for use in automobiles.

4. Warranty

The warranty for Omron Products are as follows:

- (1) Warranty period: The Warranty shall apply for one year from the date of purchase.
(Unless otherwise described in Catalogs.)
- (2) Warranty content: Omron will provide, at its own discretion, either of the following two services as the sole remedy for a malfunctioning Omron Product:
 - (a) Repair of the malfunctioning Omron Product(s) at an Omron maintenance service location at no charge to the customer (This repair service is not available for electronic/mechanical parts.)
 - (b) Replacement of the malfunctioning Omron Product(s) with the same number of replacement/alternative products at no charge to the customer.
- (3) Exceptions: This warranty of Omron Products does not apply if the cause of the malfunction falls under any of the following:
 - (a) Usage in a manner other than the original intended use for the Omron Products.
 - (b) Usage other than as described in the Usage Conditions.
 - (c) Usage that is not in accordance with Section 3 (Precautions) above.
 - (d) Modification or repair made to the Omron Products by other than Omron personnel.
 - (e) Software program by other than Omron staff
 - (f) Causes which could not have been foreseen with the level of science and technology at the time of shipping from Omron.
 - (g) Causes other than those above originating from other than Omron or Omron Products (including force majeure such as natural disasters).

5. Limitation of liability

The warranty express in this agreement is the entire warranty for this Omron product.

Omron and dealers selling Omron products accept no responsibility for damages arising from the use of Omron products.

6. Export control

Comply with the applicable laws and regulations of Japan and related nations relating to security export controls when exporting or providing this Omron product or technical documents to non-residents. If you do not comply with these laws and regulations, we may be unable to supply you with Omron products or technical documents.

Notice

- It is not permitted to reproduce, copy, or reprint this manual in part or in full without permission.
- Changes to this manual may be made without notice.
- Every effort has been made to ensure the accuracy of this manual, however please contact us or your dealer at one of the addresses shown at the back of this manual if you find any unclear points or errors.
At this time, please also advise us of the catalog number found at the back of this manual.

Safety precautions

Regarding the displays used to ensure safe operation and their meanings

The following indications and symbols are used in this manual for precautions so that you can use the product safely. The precautions here include important information regarding safety. Please follow these instructions.

The indications and symbols are as follows.

Warning displays



Indicates a potentially hazardous situation which, if not avoided, will result in minor or moderate injury, or there may be property damage.

Meanings of the symbols



- **Mandatory actions**
Indicates a general action that must be performed by the user.



- **Explosion caution**
Indicates possibility of explosion under special conditions.



- **Electrical shock caution**
Indicates possibility of electric shock under special conditions.











- **Disassembly prohibition**
This indicates that there is the danger of electric shock or other injury if the unit is disassembled.



- **General prohibitions**
Indicates a general prohibition without particular categorization.

Safety precautions(continued)

 Caution	
<p>Property damage may occur due to fire. Tighten the terminal screws to the specified torques. After tightening the screw, check that the screw is not loose. M3 screw : 0.5 to 0.58N·m M3 screw (KM-NCT-E's output terminal): 0.3N·m</p>	
<p>Minor or moderate injury or property damage may occur due to explosion. Do not use in locations exposed to flammable or explosive gases.</p>	
<p>Breakdown or explosion may occasionally occur. Use the power voltage and load within the specified and rate ranges.</p>	
<p>Electric shock may occasionally occur. Do not touch any of the terminals while the power is being supplied.</p>	
<p>Electric shock may occasionally occur. Always make sure that the power to the circuit the CT is being attached to is turned OFF before connecting the CT*.</p>	
<p>Electric shock may occasionally occur. Be sure to mount to coated wire with at least the basic insulation when mounting KM-NCT-E.</p>	
<p>Minor electric shock, fire, or malfunction may occasionally occur. Do not supply a current to the CT input terminal that exceeds the maximum CT secondary current.</p>	
<p>Minor electric shock, fire, or malfunction may occasionally occur. Never disassemble, modify, or repair the product.</p>	

* CT: Current Transformer

Important safety points

Observe the following to ensure safe use of model KM-N3.

- Do not use or store the product in any of the following locations.
 - Locations subject to shock or vibration
 - Unstable locations where the user might fall/tumble down
 - Locations subject to temperatures or humidity outside rated ranges
 - Locations subject to condensation as the result of severe changes in temperature
 - Outside or otherwise exposed to direct sunlight and weather
 - Locations subject to static electricity or other forms of noise
 - Locations exposed to electromagnetic fields
 - Locations subject to exposure to water or oil.
 - Locations subject to exposure to salt water spray.
 - Locations subject to corrosive gases (in particular, sulfide gas and ammonia gas).
 - Locations subject to dust (including iron dust).
 - Locations subject to exposure to solvents
- Be sure to wire properly with the terminals with correct symbols.
- Use AWG20 to 16 (with a cross-section of 0.5 to 1.5mm²) to wire the power supply terminals. The heat resistant temperature of the wire is 85 degree or more.
- Use AWG18 to 14 (with a cross-section of 0.75 to 2.0mm²) to wire the CT and measurement voltage terminals. Use the crimping terminals of the round shape or Y-shape compatible with the M3 screw. The heat resistant temperature of the wire is 85 degree or more.
- Use twisted or solid wire AWG24 to 16 (with a cross-section of 0.25 to 1.5mm²) to wire communication terminals. The heat resistant temperature of the wire is 85 degree or more.
- For wiring to KM-NCT-E's output terminal, use a Y-shape terminal compatible with AWG18 to 14 electric wire (with a cross-section of 0.75 to 2.0mm²) and M3 screw.
- The recommended tightening torque of the M3 screw of KM-NCT-E's output terminal is 0.3N·m.
- When mounting the KM-NCT-E to the measurement wire, push the fitting claw until it clicks.
- Before using or maintaining the product, thoroughly read and understand this manual.
- Understand the user manual before setting the device.
- Do not pull cables.
- For compliance with standards and safety, in order to protect against overcurrent, install a branch circuit protector with a rated current of 1A conforming to the voltage at which the device is used and the appropriate standards of the country where the device is used (US: UL Listed, Canada: cUL Listed, and other countries: for example, IEC60947-1 and IEC60947-2). Failure to do so may lead to an electric shock or fire. Install the branch circuit protector on the (1) L+ terminal of this product and the Line side of the power supply.
- Always check the wiring and confirm that it is correct before turning ON the power supply. Incorrect or improper wiring may result in electrical shock, injury, accidents, failure, or malfunction.
- KM-NCT-E is a dedicated CT for KM-N2-FLK and KM-N3-FLK. Do not use it for other power monitors.
- The surface temperature of the CT may become high due to the heat generated by the primary power cable. Be sure to check that the surface temperature of the CT went down before touching the CT immediately after turning ON the power supply.
- Do not install the product close to heat-producing devices (those using coil elements, for instance).
- Separate the product wiring from high-voltage or high-current power lines to prevent inductive noise. Do not place the product wiring parallel to or in the same ducts or conduits as power lines. Use separate ducts, separate conduits, or shielded cables to prevent noise.
- This is a "class A" product. In residential areas it may cause radio interference. The user may be required to take adequate measures to reduce interference if this occurs.
- Use the product by incorporating it in a panel 1 to 8 mm thick. If the panel thickness is not appropriate or the mounting method is not appropriate, the product might be come off.

Precautions for correct use

- This product is not categorized as "a specified measuring instrument" officially approved by an organization specified in relevant measurement acts. It cannot be used to certify power usage.
- Set the parameters of the product so that they are suitable for the system being measured.
- Use this product in an overvoltage category II environment. When using in an overvoltage category III environment, install a varistor between the voltage input terminal of this product and the ground to reduce the overvoltage. Select a varistor that suits your environment and conditions.
- In a power supply system where it is unearthed neutral, a varistor cannot be installed between the voltage input terminal and the ground, so it cannot be used in an overvoltage category III environment.
- This product cannot be used to measure the inverter's secondary side.
- Ensure that the rated voltage is reached within 2 seconds of turning the power on.
- When cleaning the unit, make sure the power is off and wipe the surface of the unit with a soft dry cloth. Do not use chemicals including solvents such as thinners, benzine, or alcohol.
- Use a CT whose secondary output is 1A or 5A.
- The data for active energy is saved at 5 minute intervals. The data for the 5 minutes preceding the unit powering off may not be saved under some circumstances.
- Dispose of this product appropriately as industrial refuse in accordance with local and national regulations.
- This product is intended for use in industrial environments. Do not use it in residential environment.

Trademark Information

- Modbus is a registered trademark of Schneider Electric.
 - Other company names and product names in this document are the trademarks or registered trademarks of their respective companies.
-

Precautions for correct use (continued)



Safety standard compatibility

If the equipment is used by a method not specified by the manufacturer, the equipment might lose the equipped protection.

The temporary overvoltage occurring on the main power supply must not exceed the following values:

Confirm the voltage using the power supply voltage of the product that you purchased.

Short-time overvoltage: 1200 V+ (power supply voltage)

Long-time overvoltage: 250 V+ (power supply voltage)

For safety standard compliant, Listing CT of XOBA / XOBA7 category must be used.



<Meaning of the warning symbols on the product>

Electric shock may occasionally occur. Use the product according to this content.

Heat resistant temperature of wires that are used with the product needs to be more than 85 degree.

Manual revision history

A manual revision code appears as a suffix to the catalog number on the front cover and back cover of the manual.

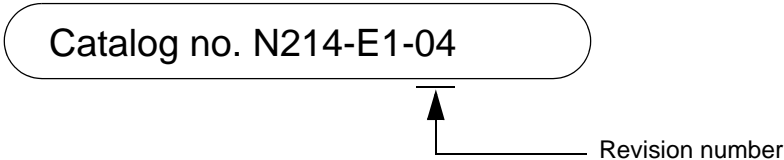

Revision number	Date of revision	Reason for revision, pages revised
01 A	August 2016	First edition
02	July 2017	UL certified. Description of operability-confirmed converter: Modified
03	May 2018	Description of dedicated CT: Added
04	March 2023	Precautions for correct use: Modified(⇒ 9) Connection of terminating resistor for RS-485: Modified(⇒ 36) Description of an example for CRC-16 calculation: Modified(⇒ 74) Description of lower limit of effective power and lower limit of reactive power: Modified(⇒ 96) Table of parameters:Added(⇒ 97) Rated input voltage when UL compliant: Added(⇒ 105) Regarding the copliance with CT standards: Added(⇒ 105)

1.1 Main features

- **Supports international standards**
It complies with the international IEC accuracy standards and can be connected using generic CTs.
 - **Multi-circuit metering**
Multi-circuit metering is possible with one unit, with up to four circuits metered by 1-phase 2-wire, and up to 2 circuits metered by 1-phase 3-wire and 3-phase 3-wire. It is also possible to measure multiple 1-phase 2-wire with different phases branching off a 1-phase 3-wire, and to simultaneously measure both 1-phase 3-wire and 1-phase 2-wire.
 - **Multi-address system**
There can be a maximum of 4 circuits in one unit. The circuits act as independent power monitors, each able to measure, each having different settings, and each able to be allocated different communications addresses. You can manage individual circuits as electricity monitors from a host system, so it is easy to build a communications system and add places for measuring.
 - **Pulse output**
The unit has 4 ports for outputting pulses each time the active energy exceeds set values. You can allocate each circuit a pulse output port in a multi-circuit metering setup.
 - **RS-485 communications**
You can use the Modbus (*1) and CompoWay/F (*2) protocols for RS-485 communications.
- *1. Modbus is a communications control system that conforms with the RTU Mode of the Modbus Protocol.
- *2. CompoWay/F is Omron's unified communication procedure for general serial communications. It has a unified framework format and has commands compliant with FINS which works well with Omron programmable controllers, for instance, simplifying communications between host devices (computers for example) and components.

1.2 Device configuration

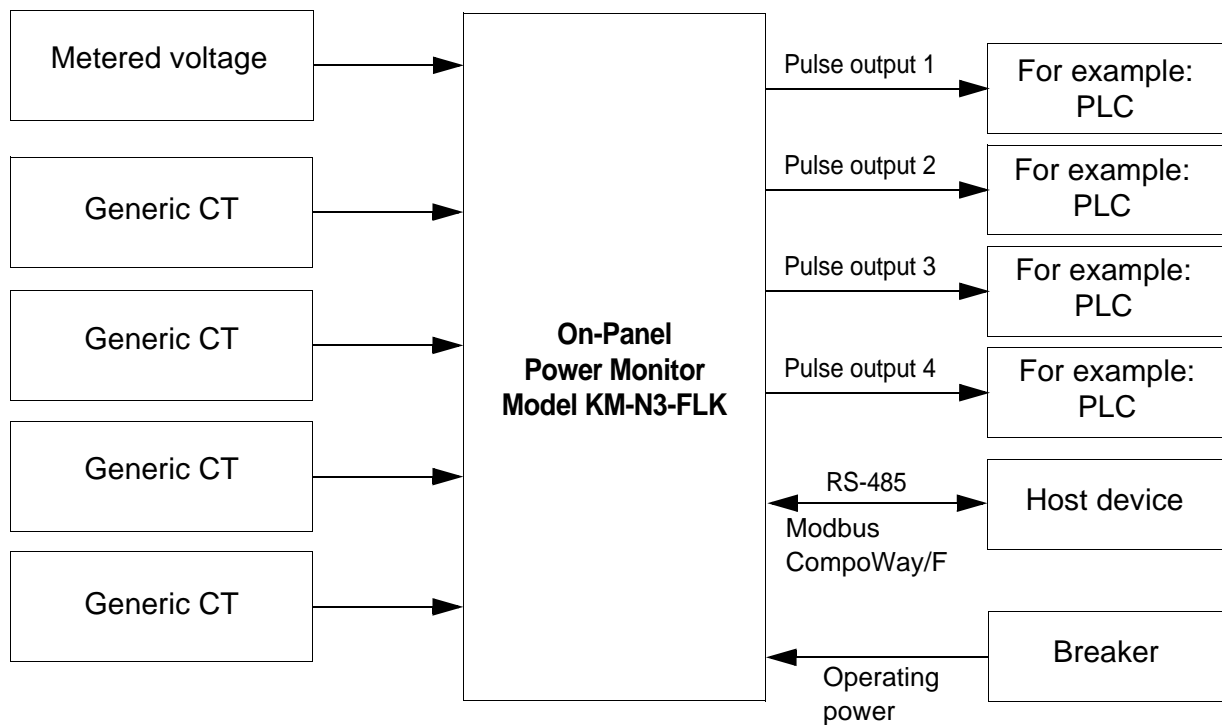

- The CT of OMRON's dedicated KM series output type cannot be used with this product.
- Although a generic CT with the secondary side output of 1A or 5A can be connected, CTs dedicated for use with KM-N2-LFK and KM-N3-FLK of 1A output type are available as listed on the table below. By using a CT listed below in combination with a KM-N3-FLK, the CE standard is supported including the use of CT and power monitors.
- A cable to connect the CT and power monitor is separately required.

Name	Model	Description
CT dedicated for 1A output type	KM-NCT-E100A	Rated 100A, output 1A
	KM-NCT-E250A	Rated 250A, output 1A
	KM-NCT-E500A	Rated 500A, output 1A

1.3 Names of the parts and their functions

[Main unit]

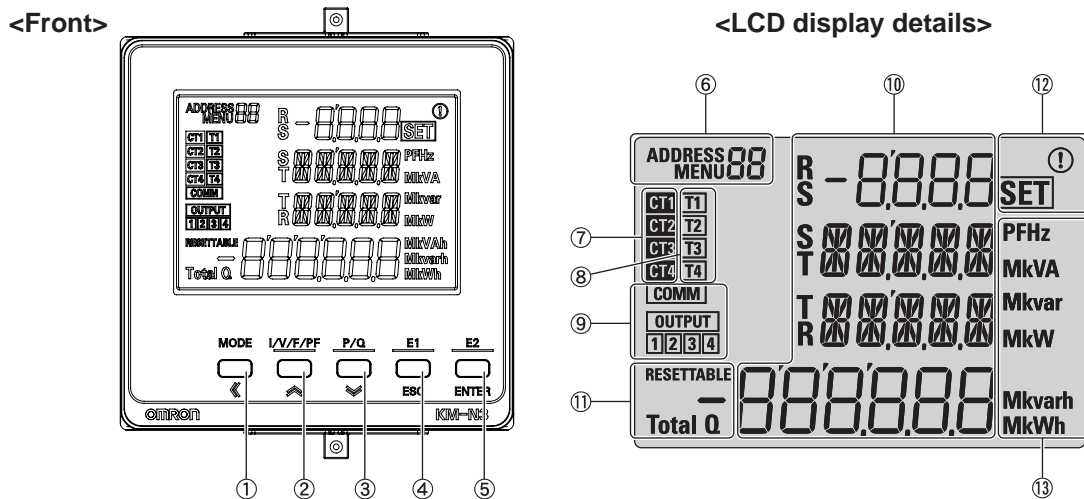

Item	Description	
① MODE•◀ Key	Long press: The measurement mode is switched with the setup mode. [MODE] key (measurement mode): The measurement circuit is changed. [◀] key (setup mode): Change of the measurement circuit / Digit shifting when a numerical value is input	
② I/V/F/PF•⤴ key	[I/V/F/PF] key (measurement mode): The display of current, voltage, frequency, or power factor is switched. [⤴] key (setup mode): Items or values are changed (up)	
③ P/Q•⤵ key	[P/Q] key (measurement mode): The display of effective power or reactive power is switched. [⤵] key (setup mode): Items or values are changed (down)	
④ E1•ESC key	[ESC] key (measurement mode): Cancel [E1] key (setup mode): The display of each integrated electric energy is switched.	
⑤ E2•ENTER key	[ENTER] key (measurement mode): Select/Determine [E2] key (setup mode): The display of each resettable integrated electric energy is switched.	
⑥ Communication address / Menu display	When ADDRESS is lit (in the measurement mode): The communication address is displayed.	
	When MENU is lit (in the setup mode): The menu number is displayed.	
⑦ In-operation CT display	The CT number in the condition of measurement or setup (CT1 to CT4) is displayed.	
⑧ Tariff display	The tariff number which is saving the integrated effective energy (T1 to T4) is displayed.	
⑨ Output/communication state display	COMM	Blinks when RS-485 communications are in progress.
	OUTPUT	Lit when the pulse output is set.
	1	Lit when pulse is output from OUT 1.
	2	Lit when pulse is output from OUT 2.
	3	Lit when pulse is output from OUT 3.
⑩ Measured value display / Setup value display	First display / instantaneous value display	Instantaneous values or setup values are displayed (on rows No. 1-3).
	Second display / Integrated value display	The integrated value is displayed (on row No. 4).

1.3 Names of the parts and their functions (continued)

<Right side surface>

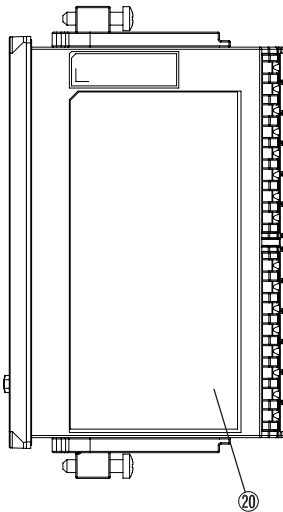

<Rear>

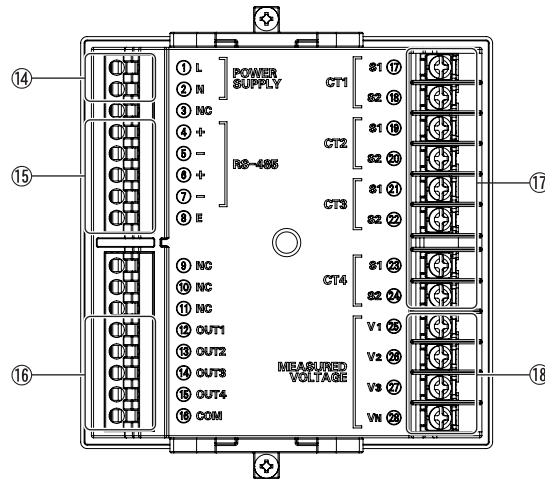

<Left side surface>

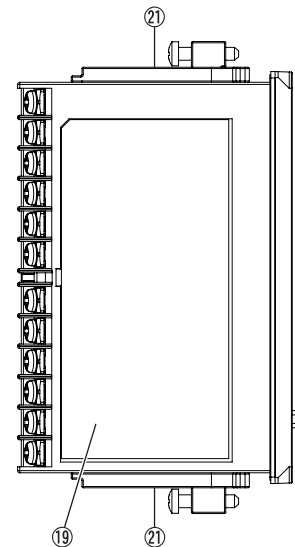

Item	Description	
⑪ Measurement auxiliary display	RESETTABLE	Lit when resettable integrated electric energy is displayed.
	-----	Lit when integrated leading reactive electric energy is displayed.
	Total Q	Lit when total integrated reactive electric energy is displayed.
⑫ State display	SET	Lit in the setup mode.
	ⓘ	Blinks when a warning occurs.
⑬ Unit display		The unit of each measured value is lit.
⑭ Power supply terminal		Power supply voltage is input to this terminal.
⑮ RS-485 communication terminal	RS-485+ (1)	RS-485 + terminal
	RS-485- (1)	RS-485 - terminal
	RS-485+ (2)	RS-485 + terminal (for transition wiring)
	RS-485- (2)	RS-485 - terminal (for transition wiring)
	RS-485E	RS-485 terminating resistor terminal
⑯ Pulse output terminal	OUT1	Circuit A pulse output terminal
	OUT2	Circuit B pulse output terminal
	OUT3	Circuit C pulse output terminal
	OUT4	Circuit D pulse output terminal
	COM	Common terminal for outputting pulse
⑰ Current input terminal		Terminal to connect the CT cable for CT1 to CT4
⑱ Measured voltage input terminal		Measured voltage is input to this terminal.
⑲ Terminal array label		Model, power supply voltage, terminal array, serial number, and so on are written on this label.
⑳ Wiring label		A wiring diagram of voltage and current is written on this label.
㉑ Mounting adapter		Adapter to fix the main unit to the panel

1.3 Names of the parts and their functions (continued)

[Dedicated CT]
KM-NCT-E100A, -250A

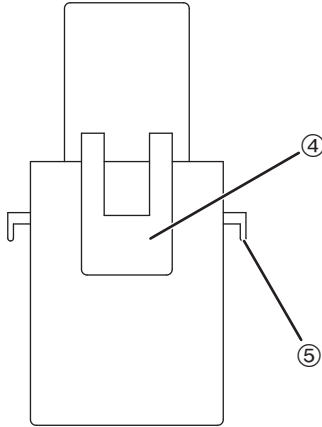

(Front)

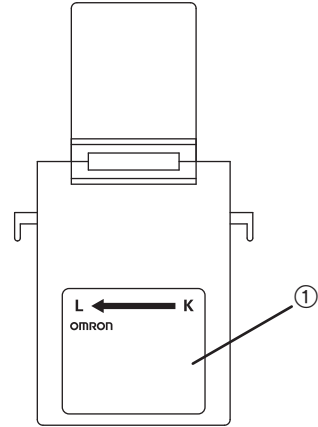

(Back)

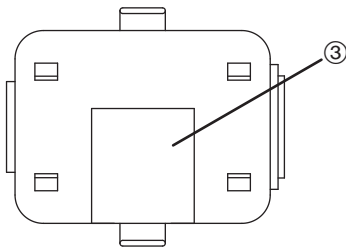

(Bottom)

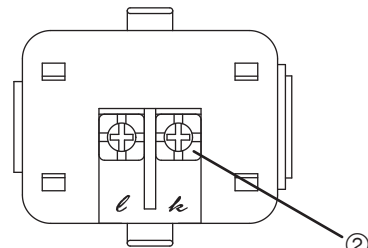

(Bottom (terminal cover removed))

Name	Function
① Label	Polarity of the primary side wiring, and models are written on this label
② Output terminal block	Secondary side current is output to this terminal block
③ Terminal cover	Protective cover of the output terminal block
④ Fitting claw	Claw that clamps the wire and fits the top and bottom of the transformer
⑤ Fixing claw	Used to reinforce the retention of the unit and insulation lock

1.3 Names of the parts and their functions (continued)

KM-NCT-E500A

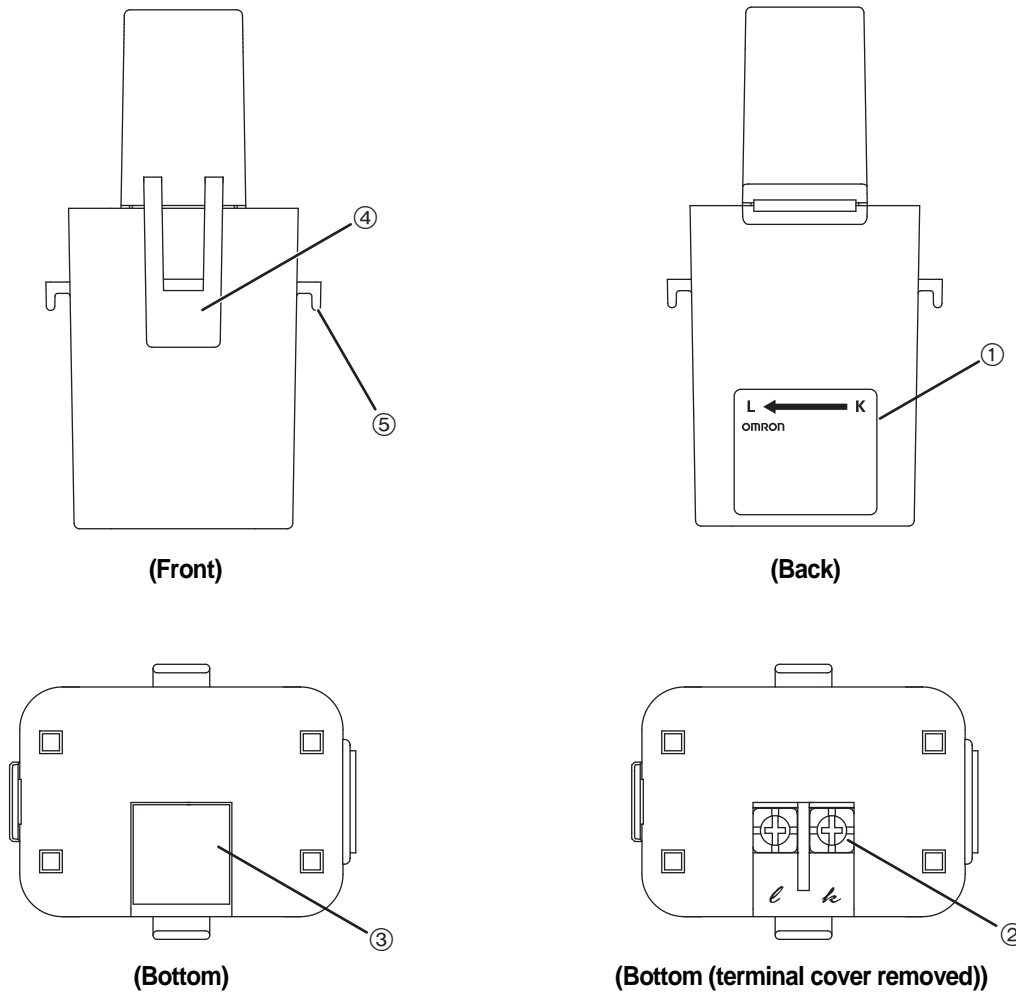

Name	Function
① Label	Polarity of the primary side wiring, and models are written on this label
② Output terminal block	Secondary side current is output to this terminal block
③ Terminal cover	Protective cover of the output terminal block
④ Fitting claw	Claw that clamps the wire and fits the top and bottom of the transformer
⑤ Fixing claw	Used to reinforce the retention of the unit and insulation lock

1.4 Dimensions

[Main unit]

Units (mm)

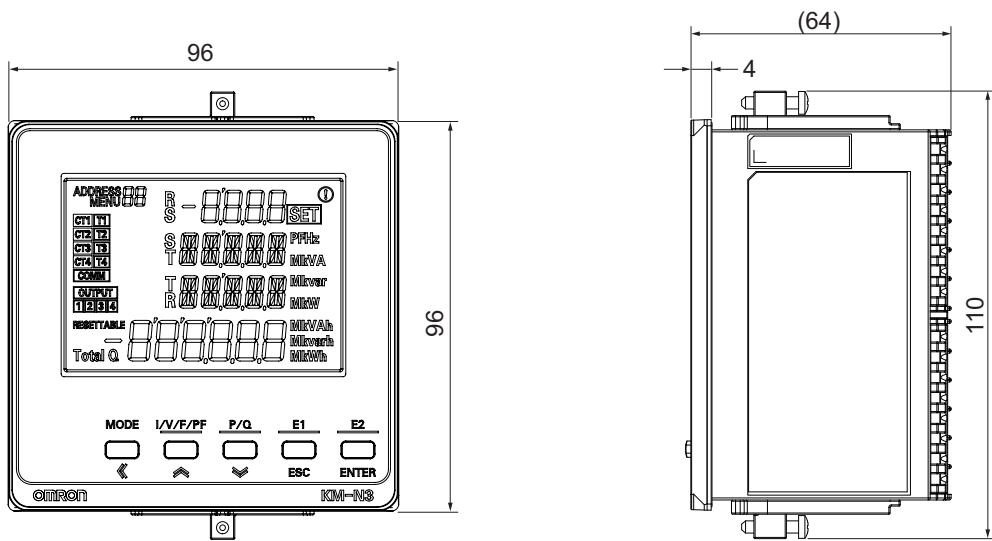

Panel cut-out dimensions for mounting

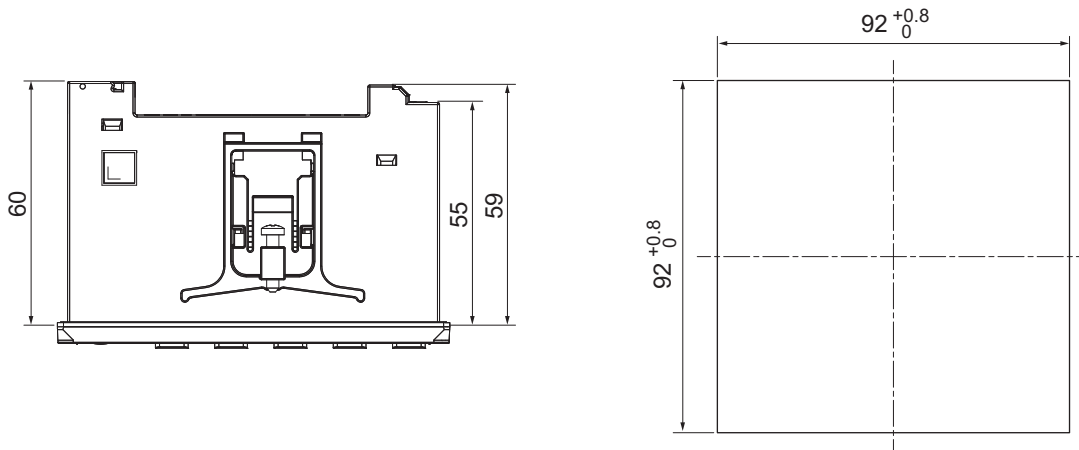

Optional Products (Order Separately)

Terminal Covers

E53-COV24 (Three Covers provided.)

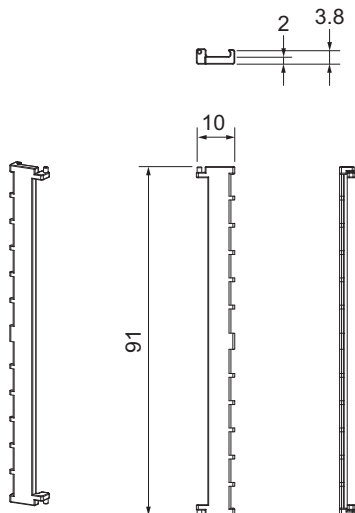

Waterproof Packing

Y92S-P10 (for DIN 96 × 96)

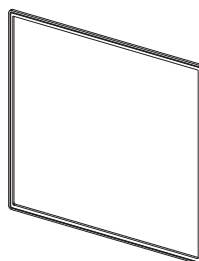

The Waterproof Packing is provided with the KM-N3. Order the Waterproof Packing separately if it becomes lost or damaged. The Waterproof Packing for the front-panel Setup Tool port must be periodically replaced because they may deteriorate, shrink, or harden depending on the operating environment. The replacement period will vary with the operating environment. Check the required period in the actual application. Use 3 years or sooner as a guideline.

Mounting Adapter

Y92F-51 (Two Adapters provided.)

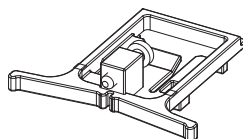

One pair is provided with the KM-N3. Order this Adapter separately if it becomes lost or damaged.

1.4 Dimensions (continued)

[Dedicated CT] KM-NCT-E100A, -250A

Units (mm)

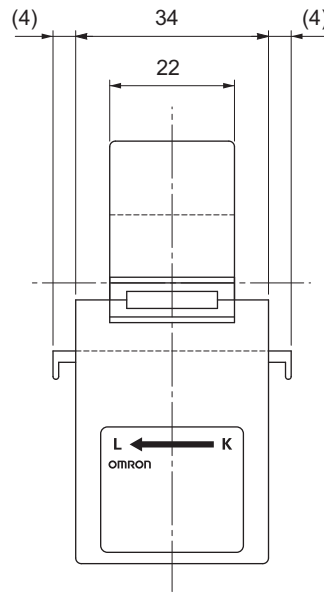
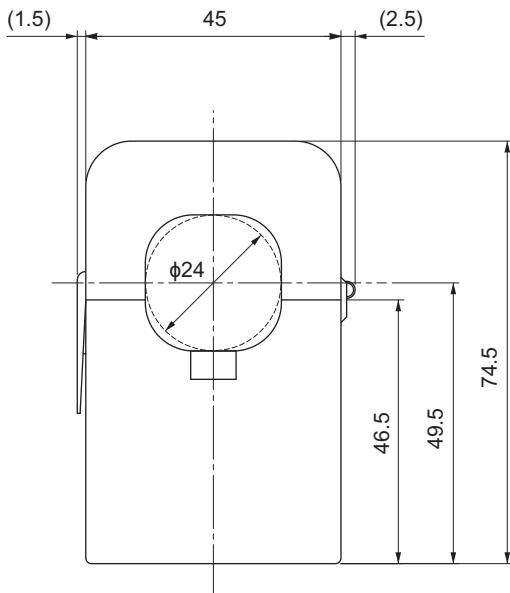

CT INNER DIAMETER

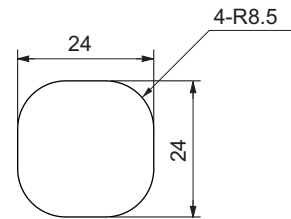

KM-NCT-E500A

Units (mm)

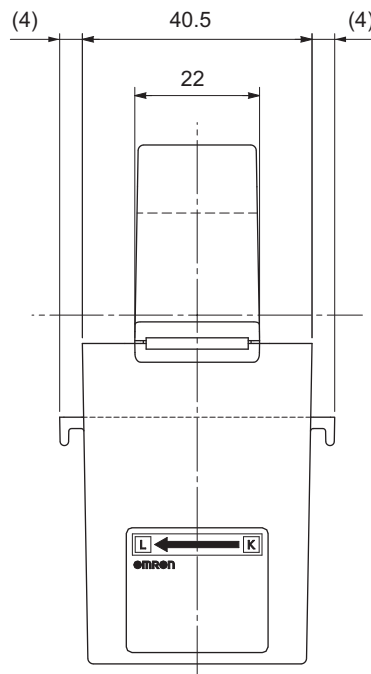
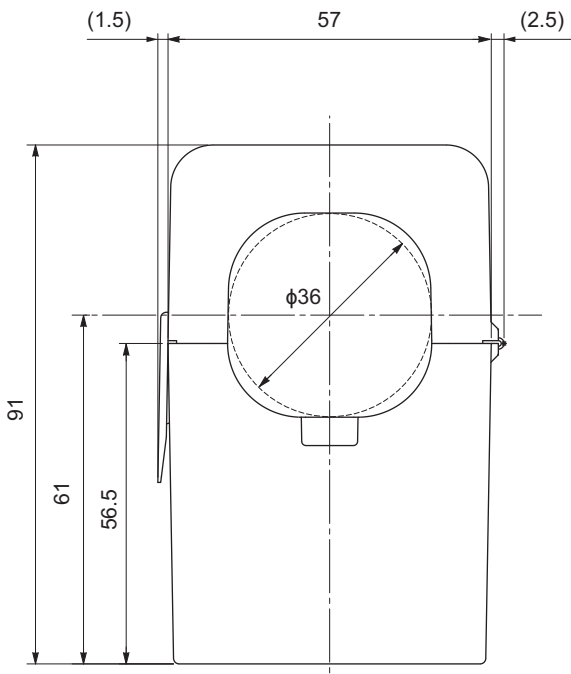

CT INNER DIAMETER

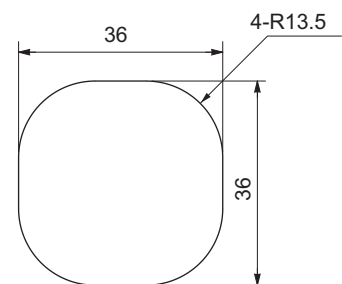

1.5 Multi-circuit metering

Multi-circuit metering is possible with this product. Measuring circuit refers to the measurement point where electricity measuring is conducted. Furthermore, this product measures voltage commonly across all circuits and measures current with each separate circuit by using generic CTs.

● Maximum number of measuring circuits for each phase and wire type

You can connect up to 4 generic CTs to this unit. The phase and wire types and the usable number of measuring circuits are shown in the following table.

Refer to "2.8Wiring diagrams (⇒ 38)" for more on wiring each of the phase and wire types.

Phase and wire type	Abbreviations for phase and wire types	Maximum number of measuring circuits	Circuits used
3-phase 4-wire	3P4W	1 circuit	Circuit A
1-phase 2-wire	1P2W	4 circuit	Circuit A, Circuit B, Circuit C, Circuit D
1-phase 3-wire	1P3W	2 circuit	Circuit A, Circuit C
3-phase 3-wire	3P3W	2 circuit	Circuit A, Circuit C
1-phase 2-wire voltage selected	1P2W2	4 circuit	Circuit A, Circuit B, Circuit C, Circuit D
1-phase 3-wire composite	1P3W2	1-phase 3-wire: 1 circuit	Circuit A
		1-phase 2-wire: 2 circuit	Circuit C, Circuit D

- Set 1-phase 2-wire voltage selected when measuring multiple 1-phase 2-wire with different phases branching off a 1-phase 3-wire switchboard. You can measure 1-phase 2-wire by selecting the corresponding voltage.
- Set 1-phase 3-wire composite to measure both the main 1-phase 3-wire switchboard and a 1-phase 2-wire branching off.
You can measure 1-phase 2-wire by selecting the corresponding voltage.
- Refer to "5.1Voltage assignment (⇒ 61)" for more on 1-phase 2-wire voltage selected and 1-phase 3-wire composite.

1.5 Multi-circuit metering (continued)

● Allocating the circuits used and the CTs for each phase and wire type

The following table shows the phase and wire types and the CT allocations for each measuring circuits. As circuit A is used irrespective of the phase and wire type, you must make settings for measurement ("Circuit A settings(⇒ 52)").

By enabling circuits B to D to increase the number of measurement points ("Settings for circuits B to D (when measuring 2 circuits or more) (⇒ 55)"), you can meter electricity using the required number of circuits. This are disabled by default.

Phase and wire type	Abbreviations for phase and wire types	Measuring circuits			
		Circuit A	Circuit B	Circuit C	Circuit D
3-phase 4-wire	3P4W	CT1, CT2, CT3	—	—	—
1-phase 2-wire	1P2W	CT1	CT2	CT3	CT4
1-phase 3-wire	1P3W	CT1, CT2	—	CT3, CT4	—
3-phase 3-wire	3P3W	CT1, CT2	—	CT3, CT4	—
1-phase 2-wire voltage selected	1P2W2	CT1	CT2	CT3	CT4
1-phase 3-wire composite	1P3W2	CT1, CT2	—	CT3	CT4

1.6 Multi-address system

This product is a multi-address system where different communications addresses (numbered in order) are allocated to each circuit. The communications addresses correspond to each measuring point, so data transmission management from the host device is simplified.

The following diagram is an overview of the multi-address system.

The measurement values and setting values for individual circuits are accessed via communications addresses for each of the circuits. The common settings are common to all of the circuits, so they can be accessed using any of the communications addresses, which allows changes to settings for all of the circuits at once.

Refer to "6.Detailed settings for communications (⇒ 72)" for details about commands, responses, and address maps.

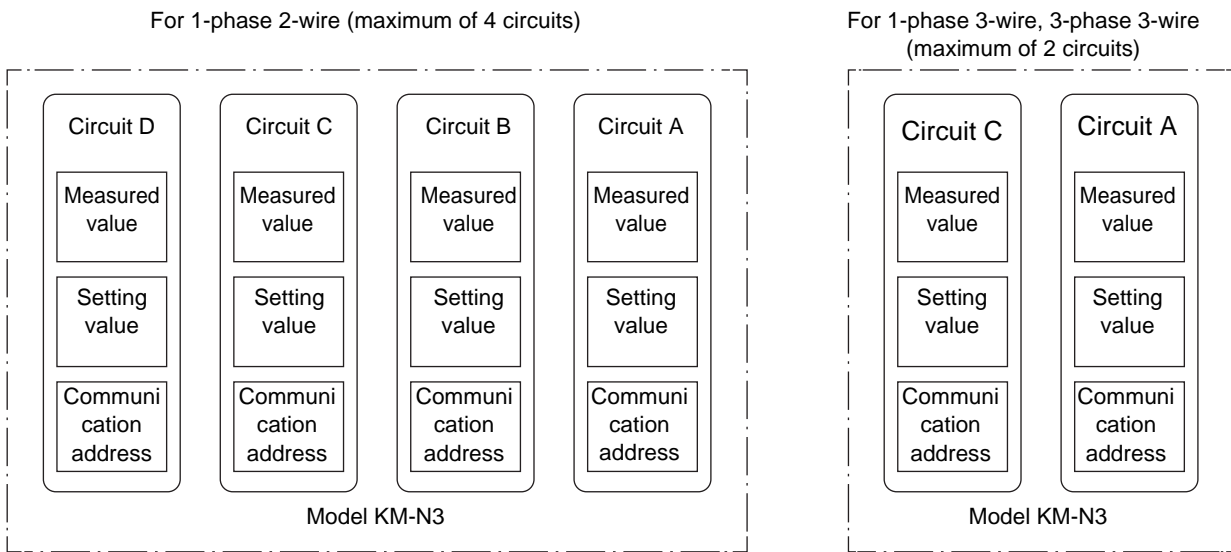

Caution

- Each circuit on this product needs to be allocated different communications addresses (numbered in order). Even if you connect several of these products on the same RS-485 line, all of the circuits need to be allocated different communications addresses.

1.7 Mode configuration

This model has three modes: measuring mode, setting mode, and communication setting mode.

- Measuring mode: The measured values for each circuit are displayed.
- Setting mode: By operating keys on the body of the unit you can change settings for each of the circuits, and make common settings for communications, output, the display, etc.
- Communication setting mode: Make settings on the units using RS-485 communication.

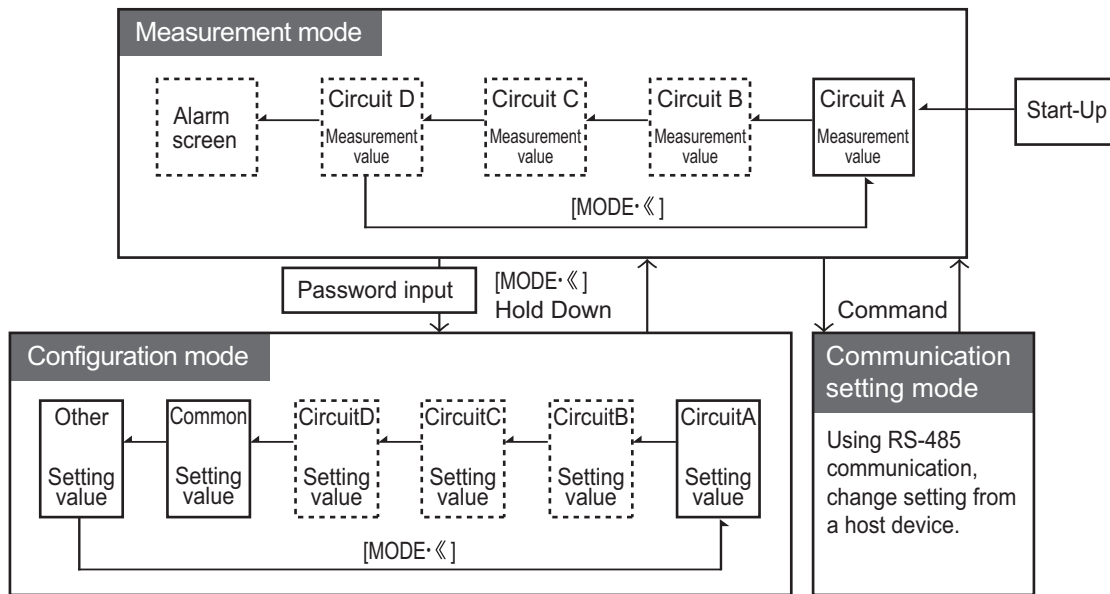

- In the measuring mode and setting mode, the circuit B to D items are displayed by switching the enable/disable settings for each of the circuits to "ON" (enabled). (The circuits indicated inside the dotted lines in the above diagram are "OFF" (disabled) in the default state.)
- The alarm screen is displayed when an alarm has occurred.

2.1 Attaching the body of the unit

For safety purposes, install the unit in a location where you won't touch the terminals when operating the main unit. For example, install so that the terminals are hidden within the control board so that a person working on the unit will not be able to touch live wires.

1 Create an opening on the panel according to the panel machining dimensions.

- Use a panel 1 to 8 mm thick.

Panel opening dimensions

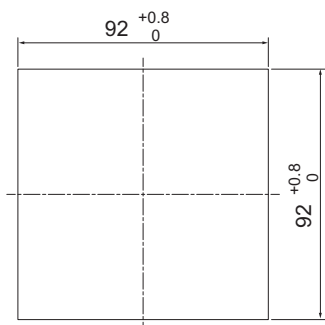

2 In order to make the unit waterproof, with the accessory waterproof packing on the front of the panel, insert the unit into the panel opening.

- Unless the waterproof packing is put, the product is not waterproof.

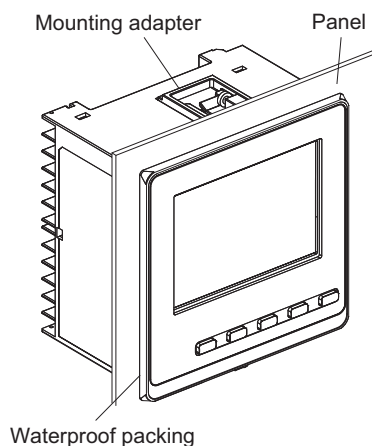

2.1 Attaching the body of the unit (continued)

- 3** Fit the attached mounting adapter into the fixing grooves on the top and bottom faces of the rear case.
- 4** Push in the mounting adapter from the terminal side until it contacts the panel to fix the main unit tentatively.
- 5** Fasten the fixing screws of the top and bottom mounting adapter alternately as keeping balance little by little.

– Apply a fastening torque of 0.29 to 0.39 N•m.

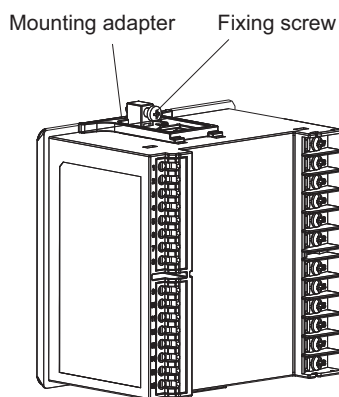

Important

- For safety purposes, install the main unit where you are not able to touch the terminals when operating the main unit. For example, install the main unit with the terminals hidden within the control board so that a person working on the unit will not be able to touch live wires.

Mounting the Terminal Cover

Slightly bend the E53-COV24 Terminal Cover to attach it to the terminal block as shown in the following diagram. The Terminal Cover cannot be attached in the opposite direction.

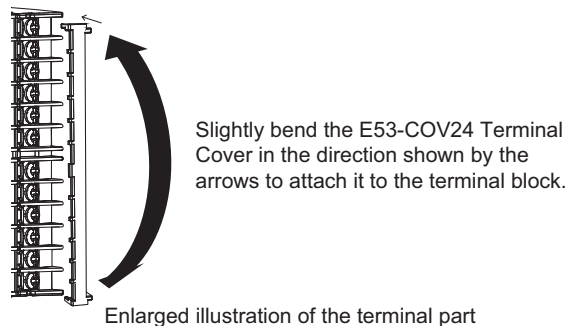

2.2 Wiring the CTs

You can connect up to a maximum of 4 generic CTs to this unit (⇒ 20). The number of CTs used depends on the phase and wire type of the power source being monitored. The following table shows the phase and wire types and the CTs to use for each. For example, use CT1 when measuring only one 1-phase 2-wire circuit. Further, when measuring two 1-phase 3-wire circuits, use CT1 and CT2 for circuit A and use CT3 and CT4 for circuit C.

The layout of CT input terminals is as follows.

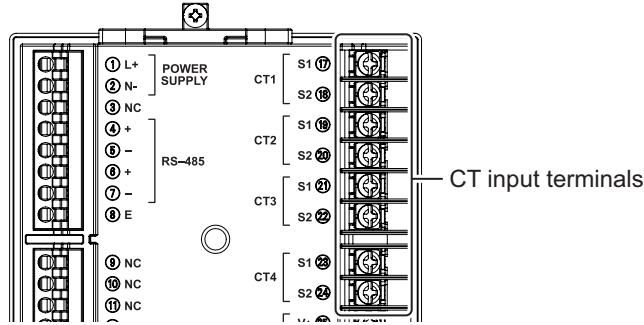

The following table shows the phase and wire types and the CT allocations for each measuring circuits.

Phase and wire type	Abbreviations for phase and wire types	Measuring circuits			
		Circuit A	Circuit B	Circuit C	Circuit D
3-phase 4-wire	3P4W	CT1, CT2, CT3	—	—	—
1-phase 2-wire	1P2W	CT1	CT2	CT3	CT4
1-phase 3-wire	1P3W	CT1, CT2	—	CT3, CT4	—
3-phase 3-wire	3P3W	CT1, CT2	—	CT3, CT4	—
1-phase 2-wire voltage selected	1P2W2	CT1	CT2	CT3	CT4
1-phase 3-wire composite	1P3W2	CT1, CT2	—	CT3	CT4

- Connect the CT cables for CT1/CT2/CT3/CT4 to the terminals on the main unit that are labeled CT1/CT2/CT3/CT4.
- For details about how to wire the CTs, connect the S1 terminal to the CT power supply side (K) and the S2 terminal to the CT load side (L). For the distinction between the power supply side (K) and load side (L) of the CT, refer to the manual of the CTs you are using.

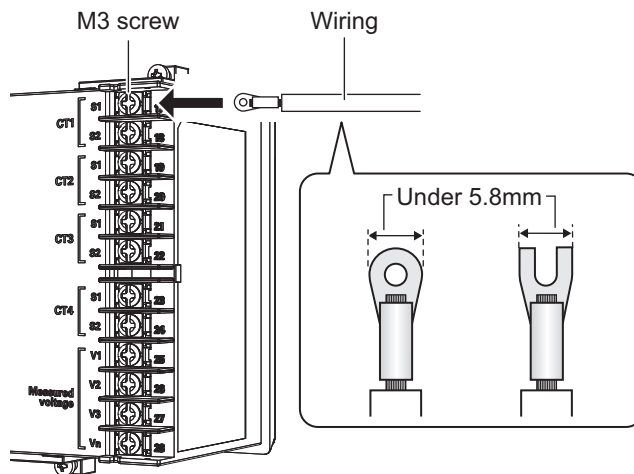

2.2 Wiring the CTs (continued)

Important

- For safety purposes, turn off the mains power and the breaker to ensure there is no power supply while you are working.
- Do not try to connect or disconnect CTs or CT cables during measurement or while the power of this product is on. There is a danger of electric shock. Furthermore, this may cause this unit and the CT to malfunction.
- To wire the CT input terminals, use AWG18-14 wire (with a cross-section of 0.75 to 2.0 mm²) and crimping terminals of the round shape or Y-shape (5.8mm wide or less) compatible with the M3 screw.
- The recommended torque for screwing the 3mm screws onto the terminal panel is 0.5 to 0.58 N·m. Make sure the crimping terminal is pushed all the way in and tightened firmly. After fixing the wiring, confirm that the wire is fixed securely.

Using KM-NCT-E□□□A

The wiring method when using the KM-NCT-E□□□A, a dedicated CT for 1A output, is as follows.

- For wiring of the output terminal of CT, use AWG18-14 electric wire (with a cross-section of 0.75-2.0mm²) and Y-shape terminal compatible with the M3 screw.
- The recommended torque for screwing the M3 screws onto the output terminal is 0.3 N·m. Make sure the Y terminal is pushed all the way in and tightened firmly. After fixing the wiring, confirm that the wire is fixed securely.
- The guideline of the maximum wiring length between the main unit and CT is as follows.

Wiring diameter	Guideline for wiring length limit
0.75 mm ² (AWG18 equivalent)	15m
2.0 mm ² (AWG14 equivalent)	43m

- The limit of the wiring length can also be calculated by the following formula. Calculate the wiring length limit according to the conductor resistivity of the wiring and keep the wiring length below the limit.
- The limits of the wiring length as shown on the table and expression below are for reference only. They do not guarantee proper use. They do not guarantee proper use.

$$\text{Wiring extension limit value (one-way) (m)} = 0.475 / \text{conductor resistivity } (\Omega/\text{m})$$

2.3 Wiring the power supply

Wire the input of the operational power supply with the power supply terminal.
The terminal layout of the power supply is as follows.

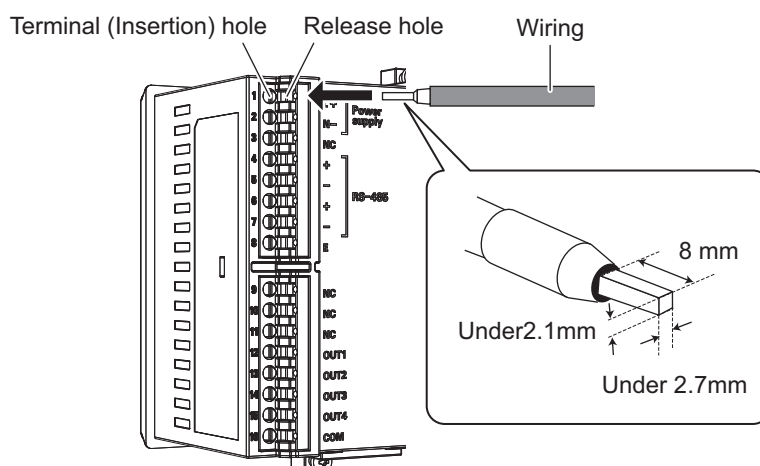
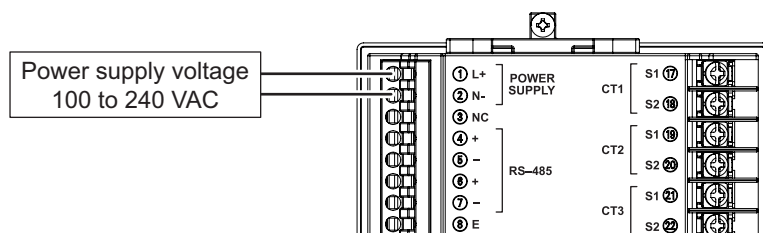

Important

- For safety purposes, turn off the mains power and the breaker to ensure there is no power supply while you are working.
- The terminal is the push-in type. Also read "Cautions when connecting the Push-In Plus terminal" when wiring.
- To wire with the power supply terminal, use AWG20-16 twisted or solid wire (with a cross-section of 0.5 to 1.5 mm²).
- Peel the wire-coating by 10 mm when using a ferrule terminal and by 8 mm when not using it.
- Use a ferrule terminal with a conductor portion 8mm long.

Recommended Ferrules

Applicable wire		Ferrule conductor length (mm)	Recommended ferrules		
(mm ²)	(AWG)		Manufactured by Phoenix Contact	Manufactured by Weidmuller	Manufactured by Wago
0.25	24	8	AI0.25-8	H0.25/12	FE-0.25-8N-YE
0.34	22	8	AI0.34-8	H0.34/12	FE-0.34-8N-TQ
0.5	20	8	AI0.5-8	H0.5/14	FE-0.5-8N-WH
0.75	18	8	AI0.75-8	H0.75/14	FE-0.75-8N-GY
1	18	8	AI1-8	H1.0/14	FE-1.0-8N-RD
1.5	16	8	AI1.5-8	H1.5/14	FE-1.5-8N-BK
Recommended crimp tool			CRIMPFOX6 CRIMPFOX6T-F CRIMPFOX10S	PZ6 roto	Variocrimp4

*1. Make sure that the outer diameter of the wire coating is smaller than the inner diameter of the insulation sleeve of the recommended ferrule.

2.4 Wiring the measured voltage input

To measure voltage, wire the measured voltage input terminal.

The terminal layout of the measured voltage input terminals is as follows.

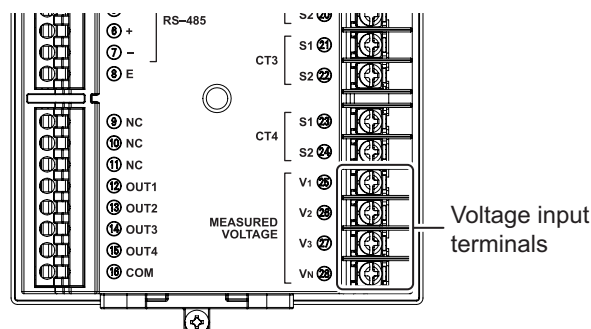

Phase and wire type	Voltage input terminals			
	V1	V2	V3	VN
4-phase 3-wire	R	S	T	N
1-phase 2-wire	L	—	—	N
1-phase 3-wire	R	—	T	N
3-phase 3-wire	R	S	T	—

Information

- R/S/T/N may be labeled U/V/W/O or L1/L2/L3/N in some cases.
- R/N/T may be labeled U/O/W or L1/N/L2 in some cases.

To wire the voltage input terminal, loosen the 3mm screw on the terminal panel, push the wire completely into the terminal, and fix in place with the crimping terminal.

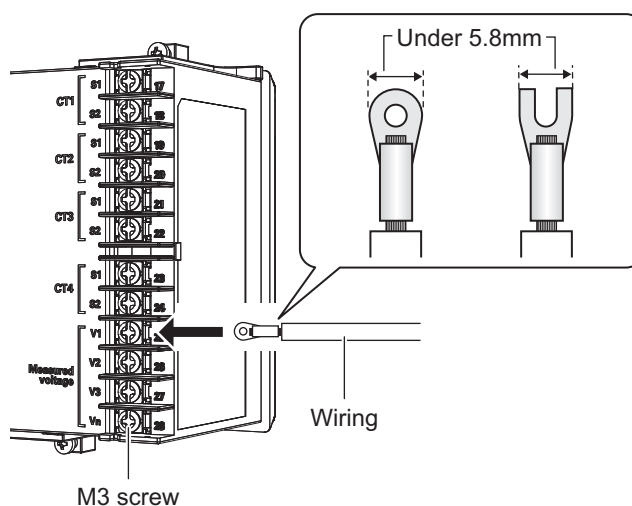

2.4 Wiring the measured voltage input (continued)

Wire the device according to the phase and wire type as shown in the following diagram.

Install a circuit breaker between the measured voltage input terminal and each wiring of R/S/T/N, L/N, and R/N/T so that the power supply can be turned OFF quickly.

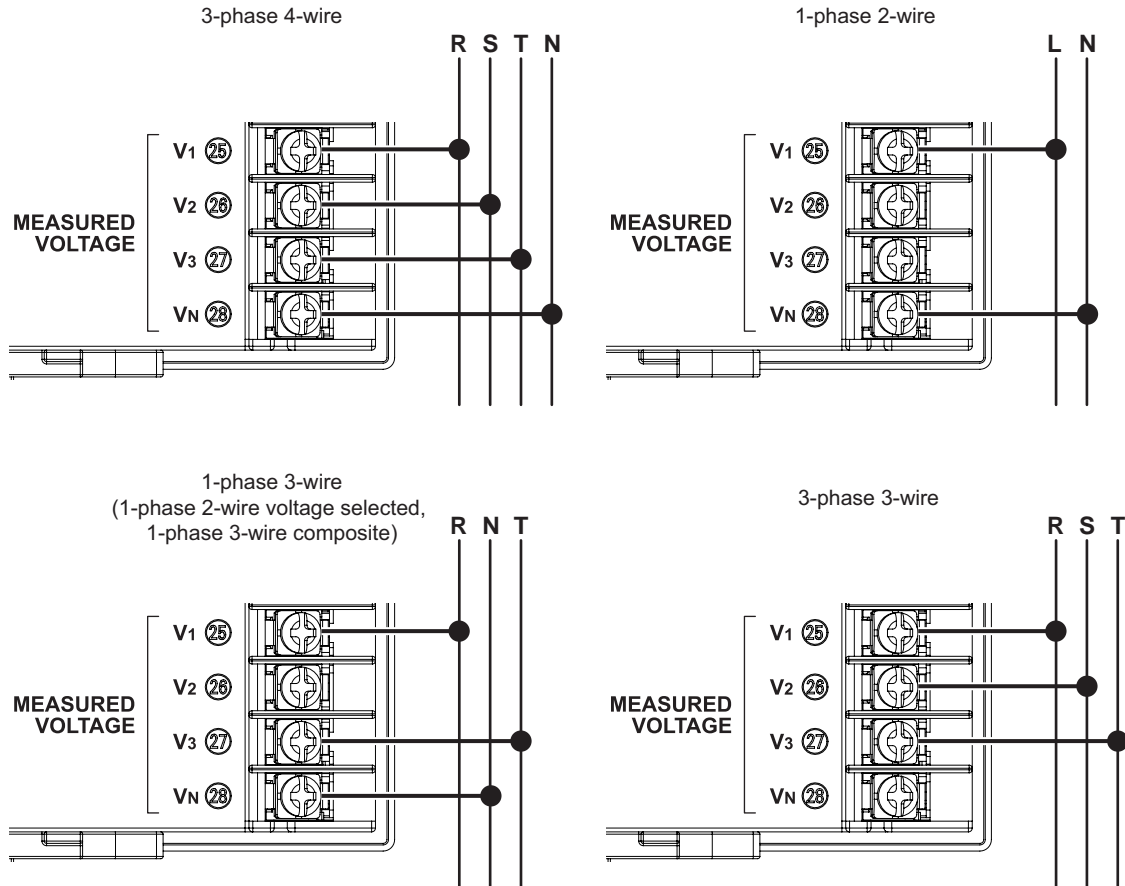

Important

- For safety purposes, turn off the mains power and the breaker to ensure there is no power supply while you are working.
- Wire correctly so the phase sequence is correct. You will be unable to measure the power and energy correctly if you fail to do so.
- To wire the voltage input terminals, use AWG18-14 wire (with a cross-section of 0.75 to 2.0 mm²) and crimping terminals of the round shape or Y-shape (5.8mm wide or less) compatible with the M3 screw.
- The recommended torque for screwing the 3mm screws onto the terminal panel is 0.5 to 0.58 N·m. Make sure the crimping terminal is pushed all the way in and tightened firmly. After fixing the wiring, confirm that the wire is fixed securely.

2.5 Fitting the CTs to the measuring wires

When monitoring one circuit with 1-phase 2-wire, you need one CT. When monitoring one circuit with 1-phase 3-wire, you need 2 CTs. When monitoring one circuit with 3-phase 4-wire, you need 3 CTs. The following diagram is an example of fitting CTs when monitoring one circuit with 1-phase 2-wire.

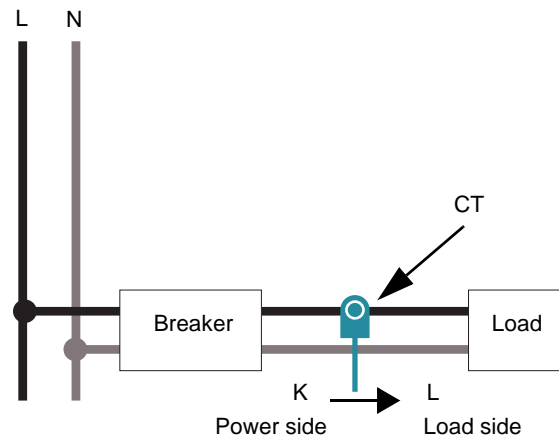

- For details about how to connect the CTs to the measuring wires, refer to the manual of the CTs you are using.
- Fit the CTs to the measuring wires after connecting the CT cables to the unit.
- Attach to the L-phase if measuring 1-phase 2-wire.
Attach to the R-phase and T-phase if measuring 1-phase 3-wire or 3-phase 3-wire.
Attach to the R-phase, S-phase, and T-phase if measuring 3-phase 4-wire.
- Refer to "2.8 Wiring diagrams (⇒ 38)" for more on attaching CTs according to the phase and wire types.
- The CT has polarity. Confirm the directions from the power side (K) to the load side (L) before connecting it. You will be unable to measure correctly if you make a mistake with the directions.

Important

- **Electric shock may occasionally occur.**
Always make sure that the power is turned OFF before connecting the CT.
- **Make sure that the primary electrical wire clamped at the CT is insulated coated wire.**
- **Do not expose the CTs to excessive vibrations or impacts.**

2.6 Pulse output wiring

Wire the pulse output terminals if using the pulse output feature. The layout of pulse output terminals is as follows.

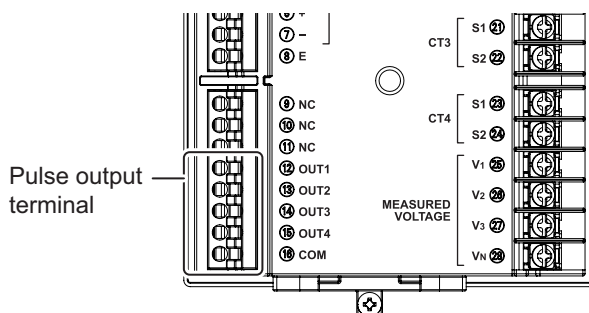

Terminal number	Terminal name	Description
12	OUT1	Pulse output 1
13	OUT2	Pulse output 2
14	OUT3	Pulse output 3
15	OUT4	Pulse output 4
16	COM	Common (common to the four outputs)

Push the wire to the very back of the pulse output terminals while pressing on the release hole. Refer to "Cautions when connecting the Push-In Plus terminal(⇒ 34)" for details about wiring and connections.

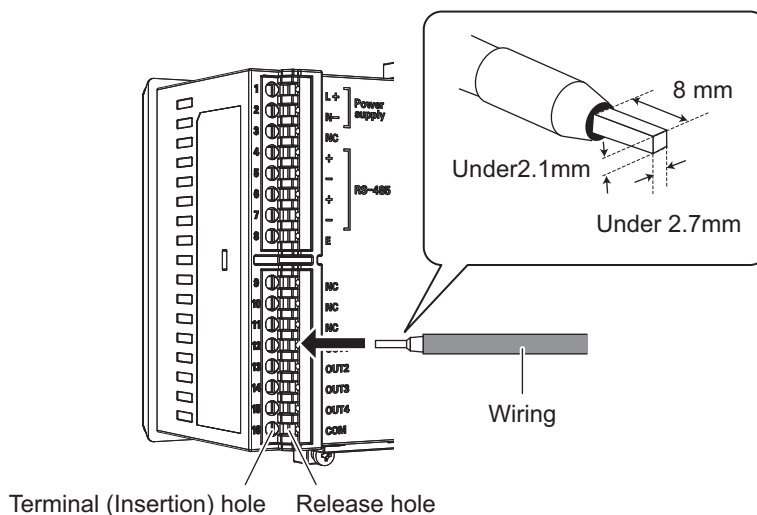

2.6 Pulse output wiring (continued)

The following diagram shows wiring for pulse output.

This unit is equipped with 4 pulse outputs. The common terminal is used commonly.

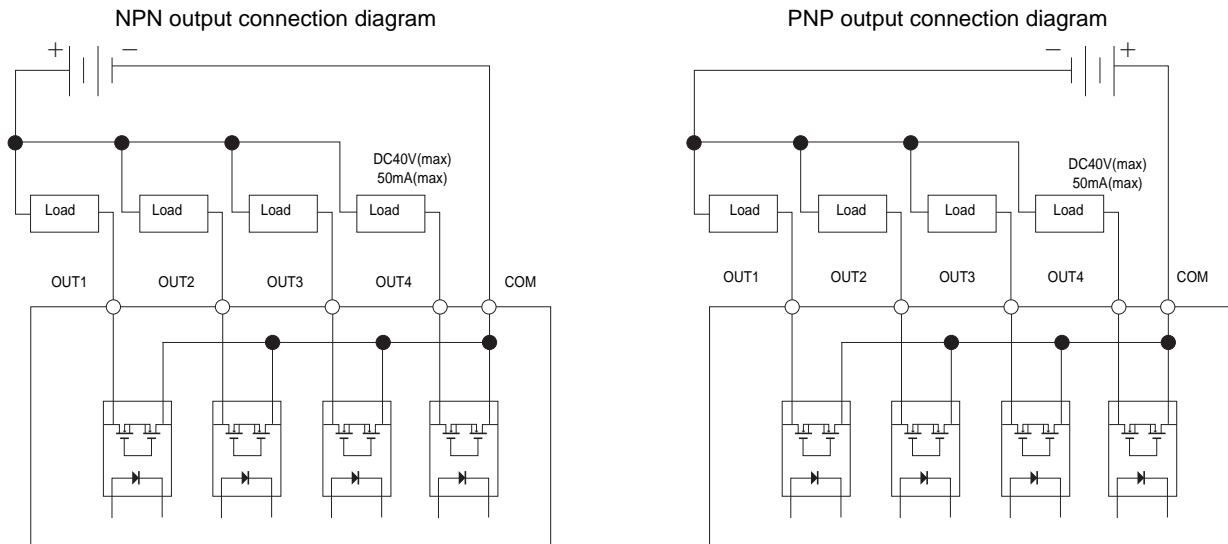

The table below shows the output specifications.

Output capacity	DC40V, 50mA or less
Residual voltage when ON	Less than 1.5V (when output current is 50mA)
Current leakage when OFF	0.1mA or less
Pulse output units	1,10,100,1k,5k,10k,50k,100kWh
Pulse ON time	500ms fixed

Important

- The terminal is the push-in type. Also read "Cautions when connecting the Push-In Plus terminal (⇒ 34)" when wiring.
- Do not directly connect an external power source to OUT or COM. Make sure the load is connected.
- To wire with the pulse output terminal, use AWG24-16 twisted or solid wire (with a cross-section of 0.25 to 1.5 mm²).
- Peel the wire-coating by 10 mm when using a ferrule terminal and by 8 mm when not using it.
- Use a ferrule terminal with a conductor portion 8mm long.
- To avoid the influence of noise, use separate wiring for the signals and for the power.
- Output for circuit A is allocated to OUT1, circuit B to OUT2, circuit C to OUT3, and circuit D to OUT4, and these allocations are fixed.

2.6 Pulse output wiring (continued)

Cautions when connecting the Push-In Plus terminal

Follow the below steps when connecting the Push-In Plus terminal (Power supply terminal, RS-485 communication terminal, and pulse output terminal).

1 Connecting Wires to Push-In Plus Terminal Block

• Part Names of the Terminal Block

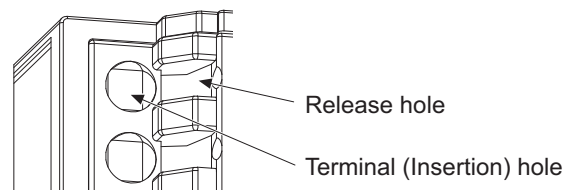

• Connecting Wires with Ferrules and Solid Wires

Insert the solid wire or ferrule straight into the terminal block until the end strikes the terminal block.

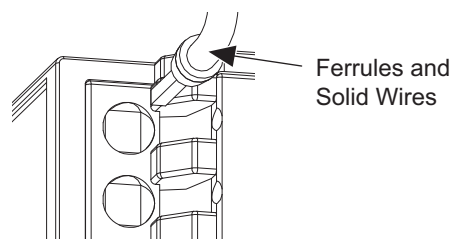

If a wire is difficult to connect because it is too thin, use a flat-blade screwdriver in the same way as when connecting stranded wire.

• Connecting Stranded Wires

Use the following procedure to connect the wires to the terminal block.

- 1 1. Hold a flat-blade screwdriver at an angle and insert it into the release hole. The angle should be between 10° and 15°. If the flat-blade screwdriver is inserted correctly, you will feel the spring in the release hole.
- 2 2. With the screwdriver still inserted into the release hole, insert the wire into the terminal hole until it strikes the terminal block.
- 3 3. Remove the flat-blade screwdriver from the release hole.

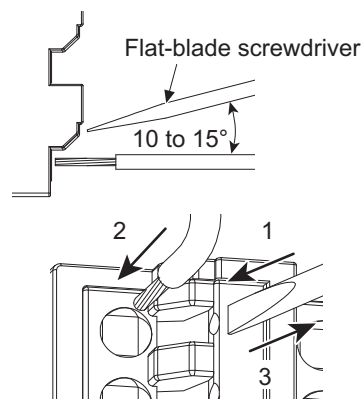

• Checking Connections

- After the insertion, pull gently on the wire to make sure that it will not come off and the wire is securely fastened to the terminal block.
- To prevent short circuits, insert the stripped part of a stranded or solid wire or the conductive part of a ferrule until it is hidden inside the terminal insertion hole. (See right diagram.)

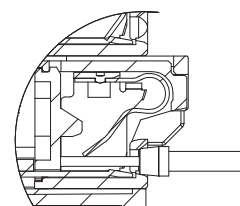

2.6 Pulse output wiring (continued)

2 Removing Wires from Push-In Plus Terminal Block

Use the following procedure to remove wires from the terminal block. The same method is used to remove stranded wires, solid wires, and ferrules.

- 1 Hold a flat-blade screwdriver at an angle and insert it into the release hole.
- 2 With the screwdriver still inserted into the release hole, remove the wire from the terminal insertion hole.
- 3 Remove the flat-blade screwdriver from the release hole.

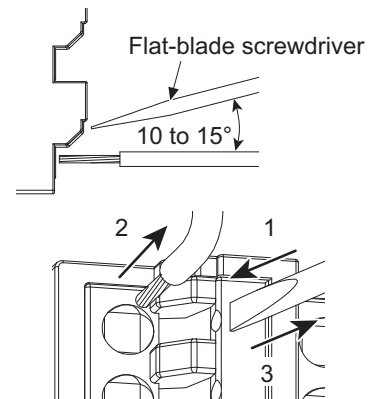

3 Recommended Tools

• Recommended Flat-blade Screwdriver

Use a flat-blade screwdriver to connect and remove wires. Use the following flat-blade screwdriver.

Model	Manufacturer
ESD0.40 x 2.5	Wera
SZF 0.4 x 2.5 SZF 0-0.4 x 2.5 *	Phoenix Contact
0.4 x 2.5 x 75 302	Wiha
AEF.2.5 x 75	Facom
210-719	Wago
SDI 0.4 x 2.5 x 75	Weidmuller

* SZF 0-0.4 x 2.5 (Phoenix Contact) is can be arranged from Omron XW4Z-00B.

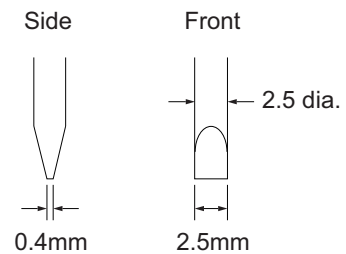

2.7 RS-485 wiring

Wire the RS-485 terminals if using the RS-485 communication feature. The layout of RS-485 terminals is as follows.

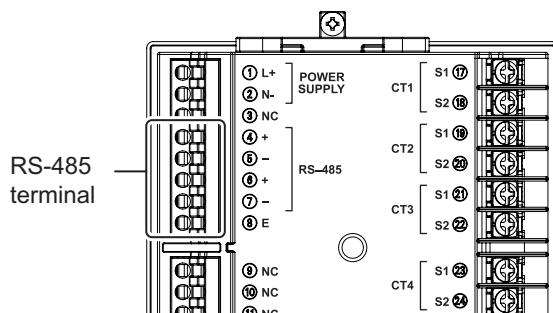

Terminal number	Terminal name	Description
4	RS-485 +	+ terminal for RS-485
5	RS-485 -	- terminal for RS-485
6	RS-485 +	+ terminal for RS-485 (for crossover wiring)
7	RS-485 -	- terminal for RS-485 (for crossover wiring)
8	RS-485 E	Terminating resistor for RS-485 (ON when shorted with terminal number 7)

Terminal number 4 and 6 and terminal number 5 and 7 are electrically connected inside this product. Push the wire to the very back of the RS-485 terminal while pressing on the release hole. Refer to "Cautions when connecting the Push-In Plus terminal (⇒ 34)" for details about wiring and connections.

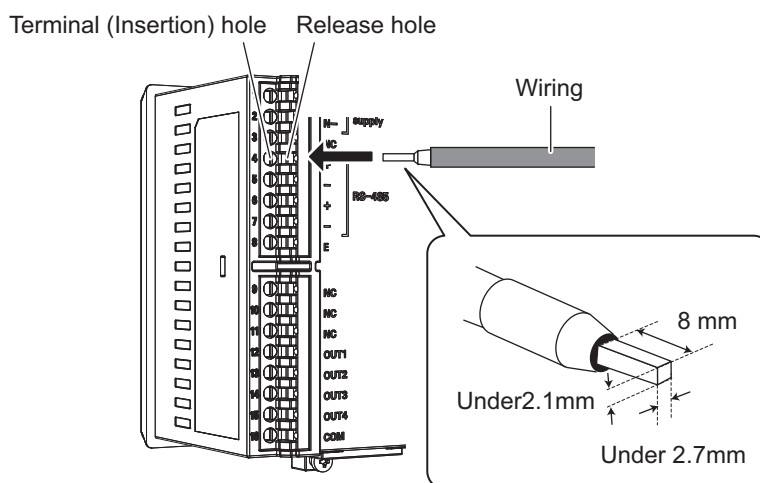

2.7 RS-485 wiring (continued)

The following diagram shows wiring for RS-485 communication.

The configuration of the connection should be either 1:1 or 1:N. If the 1:N connection is Modbus, up to 99 of this product can be connected. If CompoWay/F, up to 31 can be connected. Enable the terminating resistor that shorts terminal numbers 7 and 8 in the end unit.

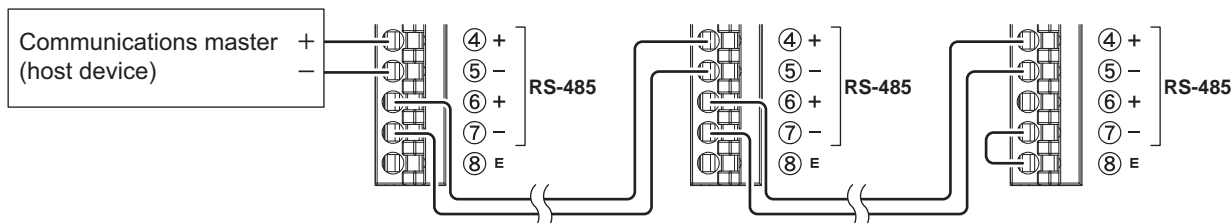

Termination settings

- This unit is equipped with a terminating resistor inside the main unit. On the unit that is the terminator for communications, short the RS-485 - terminal and the RS-485 E terminal with a cable. Connect with the internal terminating resistor.
- If the host device you are using does not have its own built in terminating resistor, connect a terminating resistor to the host device. The terminating resistance is 120Ω (1/2W).
- Do not wire in a terminating resistor terminal on KM-N3 that are along the transmission path. This can caused communication failures.

Important

- **The terminal panel is the push-in type. Also read "Cautions when connecting the Push-In Plus terminal (⇒ 34)" when wiring.**
- **The addresses for circuits B to D are automatically set, where 1 is added for each circuit in order to the address set for circuit A. Refer to "Settings for circuits B to D (when measuring 2 circuits or more) (⇒ 55)" for details.**
- **A communication address greater than 99 is invalid.**
- **There is no FG terminal on this product. Connect only the + wire and - wire of RS-485.**
- **Use twisted pair cables.**
- **To wire with the RS-485 terminal, use twisted or solid wire of AWG24-16 (with a cross-section of 0.25 to 1.5 mm²).**
- **Peel the wire-coating by 10 mm when using a ferrule terminal and by 8 mm when not using it.**
- **Use a ferrule terminal with a conductor portion 8mm long.**
- **To avoid the influence of noise, use separate wiring for the RS-485 communications and for the power.**
- **The maximum transmission distance is 1200m.**
- **Irrespective of the transmission distance and number of units connected, perform communications checks with the actual units.**

[Reference]

- If the upstream device does not support RS-485 communications, refer to the table below to select a converter for your purpose.

Protocol	KM-N Setting Tool	USB/RS-485 converter operability confirmed
Modbus	Yes	SI-35USB (LINEEYE Co., Ltd.)
	No	
CompoWay/F	Yes	K3SC-10 (Omron), SI-35USB (LINEEYE Co.,Ltd.)
	No	

2.8 Wiring diagrams

The below table shows the wiring for voltage, current, and CT by each phase and wire type.

■ For 3-phase 4-wire

3-phase 4-wire measures one circuit, as shown in the following diagram.

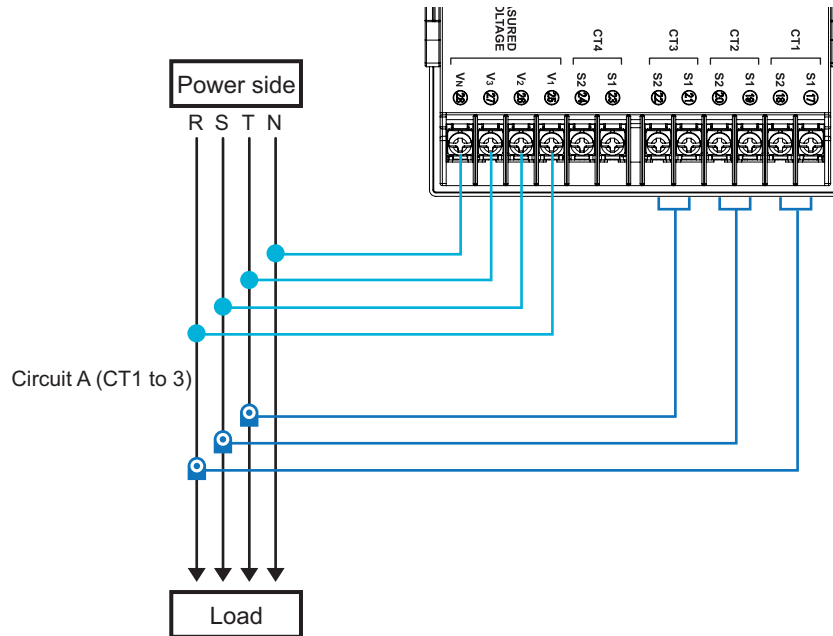

■ For 1-phase 2-wire

As shown below, 1-phase 2-wire can measure a maximum of 4 circuits. The CT must be attached to the L-phase.

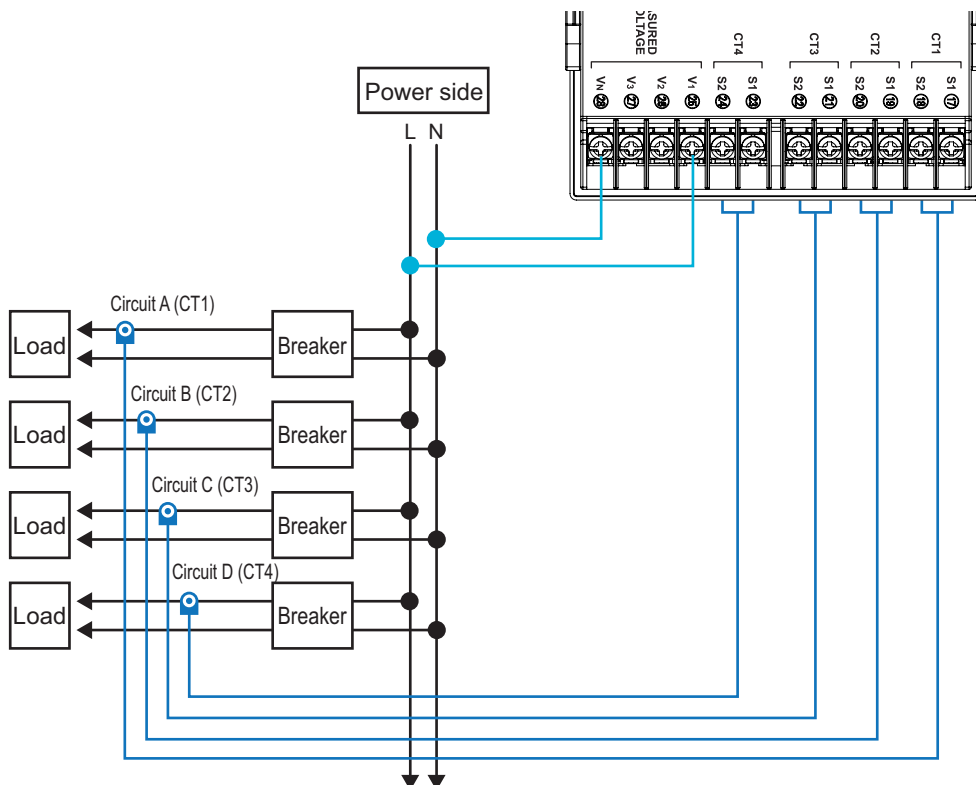

2.8 Wiring diagrams (continued)

The following wiring is also possible as a further method of measuring.

■ For 1-phase 2-wire voltage selected

The 1-phase 2-wire branching off from the 1-phase 3-wire is measured. With this connection, a setting is required according to which of R-N phase, T-N phase, or R-T phase is connected to the 1-phase 2-wire circuit. (⇒ 61) The CT must be attached to the R-phase or the T-phase.

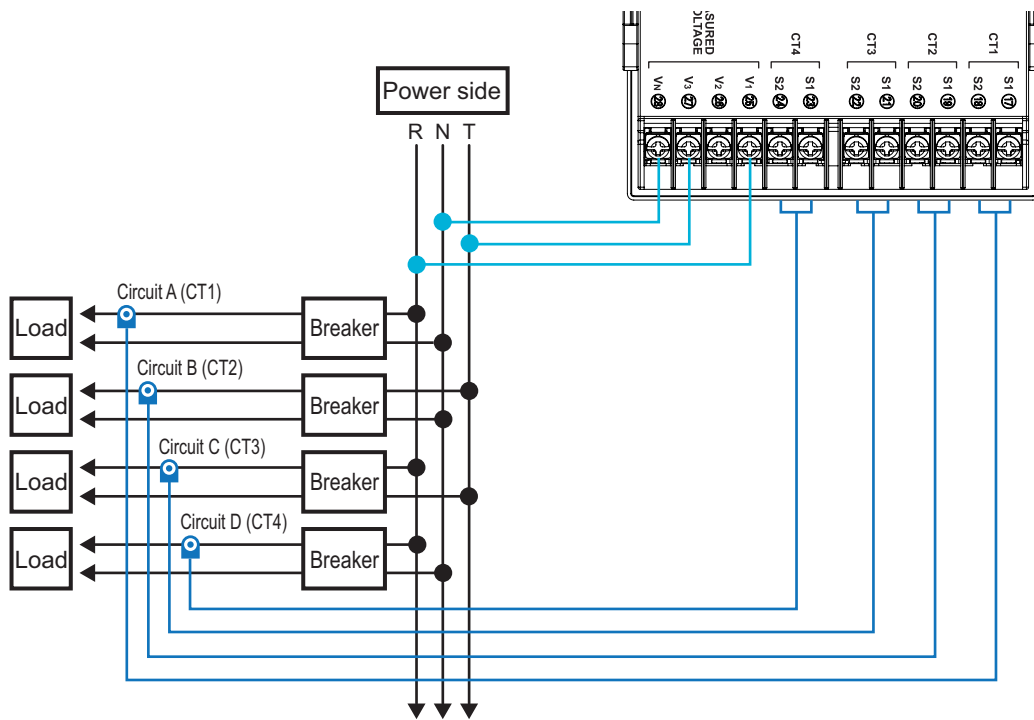

■ For 1-phase 3-wire composite

The 1-phase 3-wire circuit and the 1-phase 2-wire branching off from it are measured at the same time. With this connection, a setting is required according to which of R-N phase, T-N phase, or R-T phase is connected to the 1-phase 2-wire circuit. (⇒ 61) The 1-phase 2-wire circuit CT must be attached to the R-phase or the T-phase.

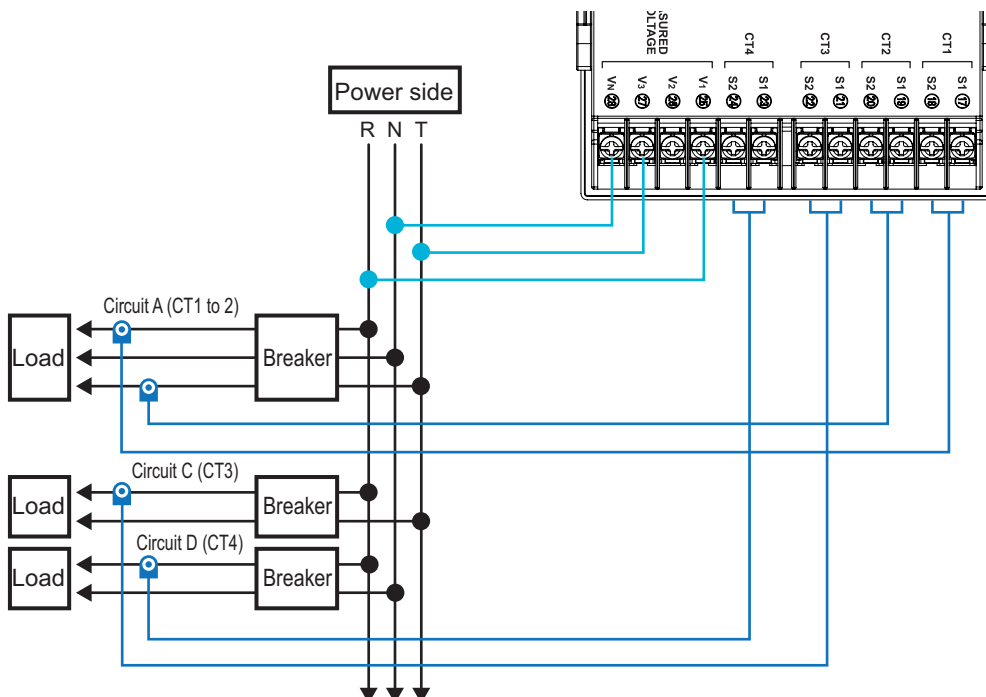

3.1 Turning the power on

Important

- Before turning on the power, ensure that there are no problems with the wiring.

Turn ON the circuit breaker to power up this product.

- The software version is displayed on the main display, and model "KM-N3" is displayed on the first display.
- The system moves to the measurement mode automatically, displaying the effective power of circuit A (each phase, kW) and the integrated effective energy (kWh).

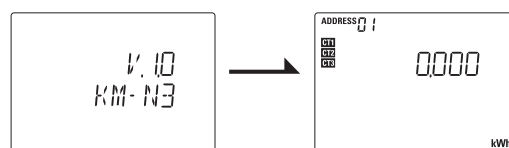
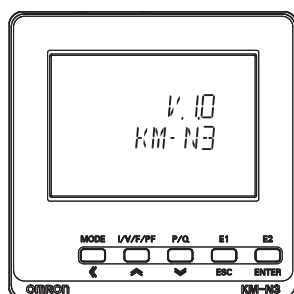

(An example of software version 1.0.x)

3.2 Switching between modes

Switching between the measuring mode and the setting mode

Switch between the measuring mode and setting mode by pressing and holding the [←/MODE] key.

- "Press and hold" means pressing the key for 1 or more seconds.

■ Measuring mode → Setting mode

- Screen to enter the password
- Enter password (password authentication OK)
- "SET MODE" displayed → Setting mode

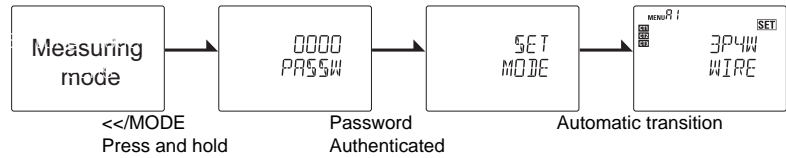

The initial password is "0001."

■ Setting mode → Measuring mode

- 1 If settings are not changed in the setting mode "MEASR MODE" displayed → Measuring mode
- 2 If settings are changed in the setting mode "SAVE" display → restart → Measuring mode – Restarting is done automatically.

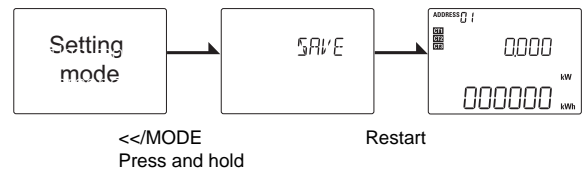
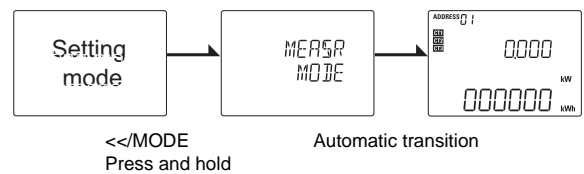

Switching between the measuring mode and the communication setting mode

You can switch between the communication setting mode and the measuring mode by sending particular commands. Refer to "6.Detailed settings for communications (⇒ 72)" for details about the commands to move to each mode.

■ Switching from measuring mode to communication setting mode

- Command sent → "COMM MODE" displayed ("COMM MODE" is displayed while in communication setting mode)

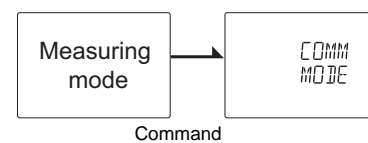

■ Switching from communication setting mode to measuring mode

- Command sent → "MEASR MODE" displayed → Measuring mode
- 1 If settings are not changed in the communication setting mode "MEASR MODE" displayed → Measuring mode
- 2 If settings are changed in the communication setting mode "SAVE" displayed → restart → Measuring mode – Restarting is done automatically.

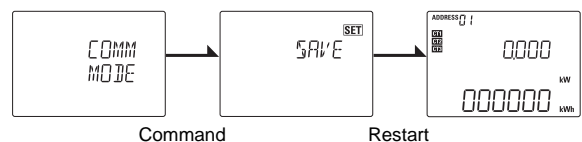
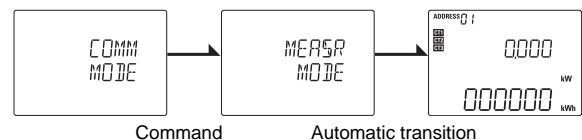

3.2 Switching between modes (continued)

Switching between the setting mode and the communication setting mode

You can switch between the setting mode and the communication setting mode by sending particular commands. Refer to "6.Detailed settings for communications (⇒ 72)" for details about the commands.

It is not possible to move from the communication setting mode to the setting mode.

■ Switching from the setting mode to the communication setting mode

Command sent → "COMM MODE" displayed

("COMM MODE" is displayed while in communication setting mode)

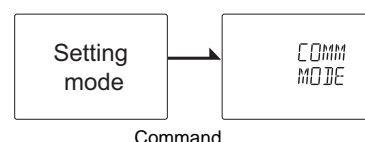

How to enter the password

- When moving from the measuring mode to the setting mode, you need to enter the password that has been set.
- The default password is "0001".
- You can set a password of 4 numerals between 0000 and 9999. Change the password as necessary. (5.7Change password (⇒ 67))

■ Enter the password (Ex.: enter password "3060")

- 1 Enter "3060" with the [↵][⇐] keys in the password entry screen.
 - Press the [MODE•⏪] key to move one place to the left.
 - If you press the [MODE•⏪] key on the end at the left, the cursor moves to the right end.
- 2 The password is verified when you press the [ENTER] key and "OK" is displayed. After this, the transition to setting mode is automatic.



"NG" is displayed if the password you entered was wrong.
Reenter the password.

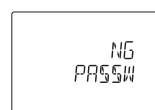

3.3 How to read the measurements

The measurements are shown for circuits A to D in the measuring mode. Depending on the phase and wire type selected, the display changes as follows.

The parts in broken lines (circuits B to D) are displayed if you have enabled the circuit settings (⇒ 55).

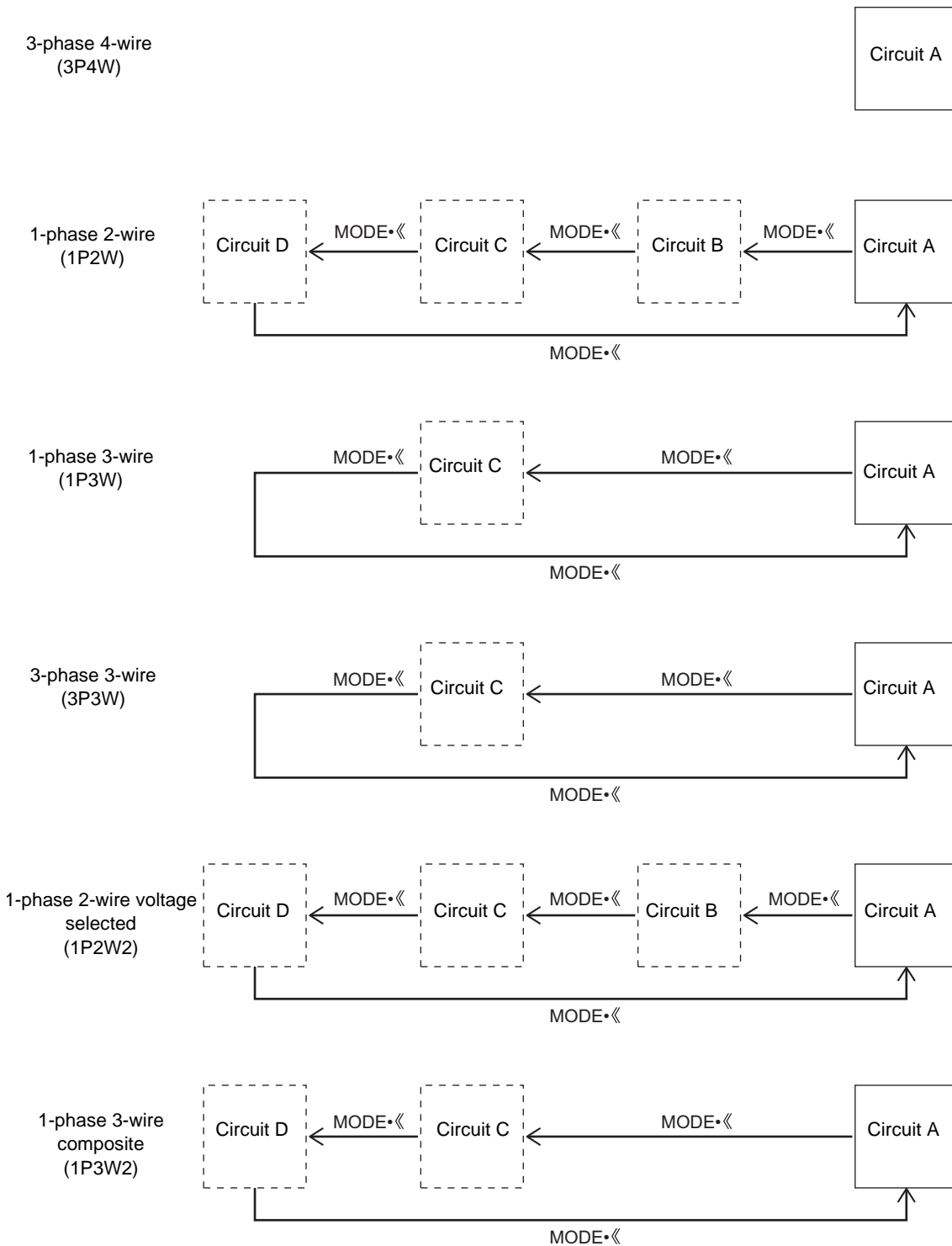

3.3 How to read the measurements (continued)

● Switching circuits

When the [MODE◀] key is pressed, the measuring items are displayed after the screen for showing the destination circuit.

- The measuring items for circuits B to D are displayed when the circuit settings are enabled (ON).
- With 3P4W, only circuit A is displayed. With 1P3W and 3P3W, only circuits A and C are displayed.
- By pressing the [I/V/F/PF], [P/Q], [E1], or [E2] key, the measuring items are switched.
- When an alarm has occurred, the screen transits to not only the screen displaying the measured values but also the screen displaying the alarm details.

(1P2W display example)

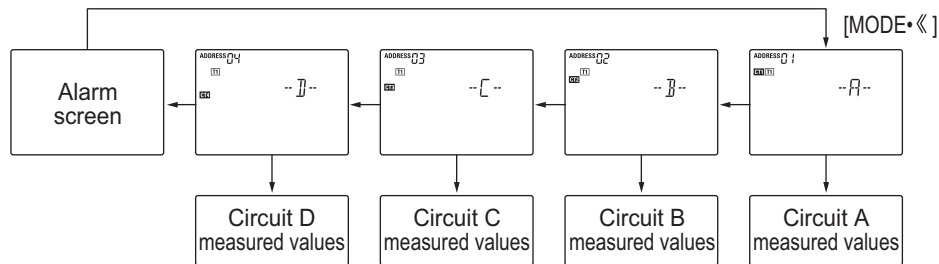

(Display of circuit A measured values)

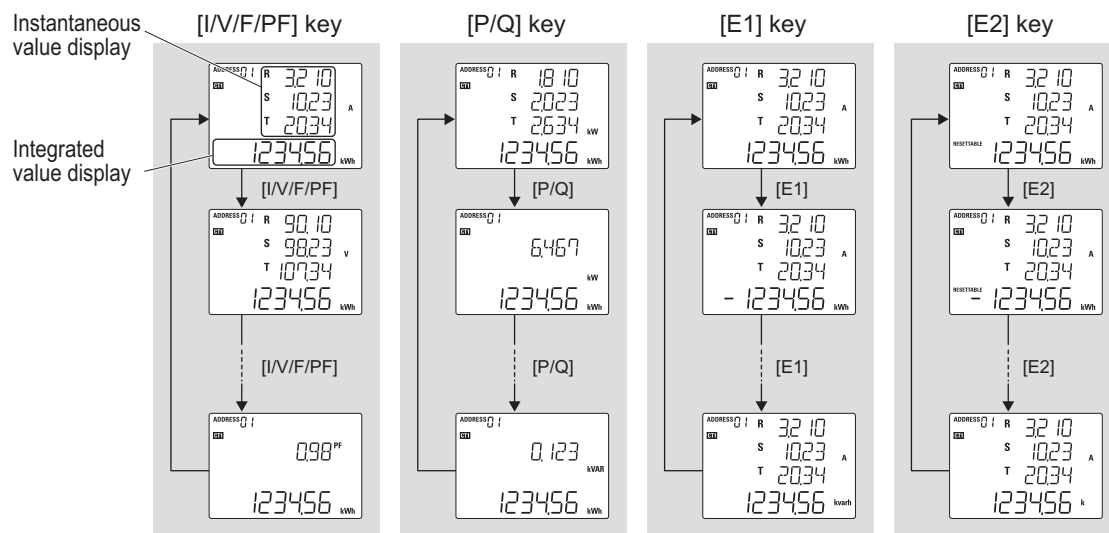

*By pressing the [I/V/F/PF] or [P/Q] key, the instantaneous value display is switched.

*By pressing the [E1] or [E2] key, the integrated value display is switched.

● Switching the measured values display

The measurement items are switched by pressing the [I/V/F/PF] key, [P/Q] key, [E1] key, or [E2] key. Depending on the phase and wire type, some items are not displayed.

- Refer to "Measurement display list (⇒ 46)" for details about measuring items.

■ Display of CTs used

The measurements are shown for each of the circuits in the measuring mode. The CTs being used by each circuit are displayed in the display of CTs used at this time.

For example, for 1-phase 3-wire or 3-phase 3-wire, the measurement display for circuit A also displays CT1 and CT2 as shown at right.

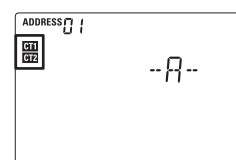

3.3 How to read the measurements (continued)

■ Measurement display list

	key	Item	Instantaneous value display	Integrated value display	units
1	I/V/F/PF	Current	0.000 to 9999	----	A
2		Voltage A *1	0.000 to 9999	----	V/kV
3		Voltage B *2	0.000 to 9999	----	V/kV
4		Frequency	45.0 to 65.0	----	Hz
5		Power factor	-1.00 to 1.00	----	PF
1	P/Q	Active power (each phase)	-9999 to 9999	----	kW/MW
2		Active power (total)	-9999 to 9999	----	kW/MW
3		Reactive power (each phase)	-9999 to 9999	----	kvar/Mvar
4		Reactive power (total)	-9999 to 9999	----	kvar/Mvar
1	E1	Active energy (import)	----	0 to 999999	kWh/MWh
2		Active energy (export)	----	0 to 999999	kWh/MWh ("-" is lit)
3		Cumulative total reactive power	----	0 to 999999	kvarh/Mvarh ("Total Q" is lit)
4		Reactive energy (import)	----	0 to 999999	kvarh/Mvarh ("-" is lit)
5		Reactive energy (export)	----	0 to 999999	kvarh/Mvarh
6		T1 active energy (import)	----	0 to 999999	kWh/MWh
7		T2 active energy (import)	----	0 to 999999	kWh/MWh
8		T3 active energy (import)	----	0 to 999999	kWh/MWh
9		T4 active energy (import)	----	0 to 999999	kWh/MWh
1	E2	Active energy (import) (resettable)	----	0 to 999999	kWh/MWh ("RESETTABLE" is lit)
2		Active energy (export) (resettable)	----	0 to 999999	kWh/MWh ("-" is lit) ("RESETTABLE" is lit)
3		Cumulative total reactive power (resettable)	----	0 to 999999	kvarh/Mvarh ("Total Q" is lit) ("RESETTABLE" is lit)
4		Reactive energy (import) (resettable)	----	0 to 999999	kvarh/Mvarh ("-" is lit) ("RESETTABLE" is lit)
5		Reactive energy (export) (resettable)	----	0 to 999999	kvarh/Mvarh ("RESETTABLE" is lit)
6		T1 active energy (import) (resettable)	----	0 to 999999	kWh/MWh ("RESETTABLE" is lit)
7		T2 active energy (import) (resettable)	----	0 to 999999	kWh/MWh ("RESETTABLE" is lit)
8		T3 active energy (import) (resettable)	----	0 to 999999	kWh/MWh ("RESETTABLE" is lit)
9		T4 active energy (import) (resettable)	----	0 to 999999	kWh/MWh ("RESETTABLE" is lit)
10		Conversion value	----	0 to 999999	N/A

*The unit such as k or M is switched automatically.

- The unit of voltage is switched to 1.000kV if exceeding 999.9V.
- The unit of effective power is switched to 1.000MW if exceeding 999.9kW.
- The unit of effective power is switched to -1.000MW if becoming lower than -999.9kW.
- The unit of reactive power is switched to 1.000Mvar if exceeding 999.9kvar.
- The unit of reactive power is switched to -1.000Mvar if becoming lower than -999.9kvar.
- The unit of integrated effective power is switched to 1000.00MWh if exceeding 999999kWh.
- The unit of integrated reactive power is switched to 1000.00Mvar if exceeding 999999kWh.
- The unit of calculated value is switched to 1000.00k if exceeding 999999 and 1000.00M if exceeding 999999k.

*Although the indication value of the model KM-N3 main unit is returned to zero when the integrated value has reached the maximum, the unit continues to integrate the measured value. Correct values can be obtained by using the communication function.

Voltage A: The phase voltage and line voltage of the each phase and wire type are displayed.

Voltage B: The line voltage is displayed only for the three-phase four-wire type.

3.4 How to read the setting values

The setting mode is organized into the categories "Individual setting items for circuits A to D", "Common settings", and "Other settings".

Category	Description
Circuits (A, B, C, D)	Individual setting items for the circuits
Common (CMMN)	Setting items common to all of the circuits (communication, pulse output, etc.)
Others (ETC)	Settings for initializing, resetting cumulative values, etc.

Depending on the phase and wire type selected, the displayed settings change as follows. The setting items for circuits in the broken lines are displayed if you have enabled the circuits.

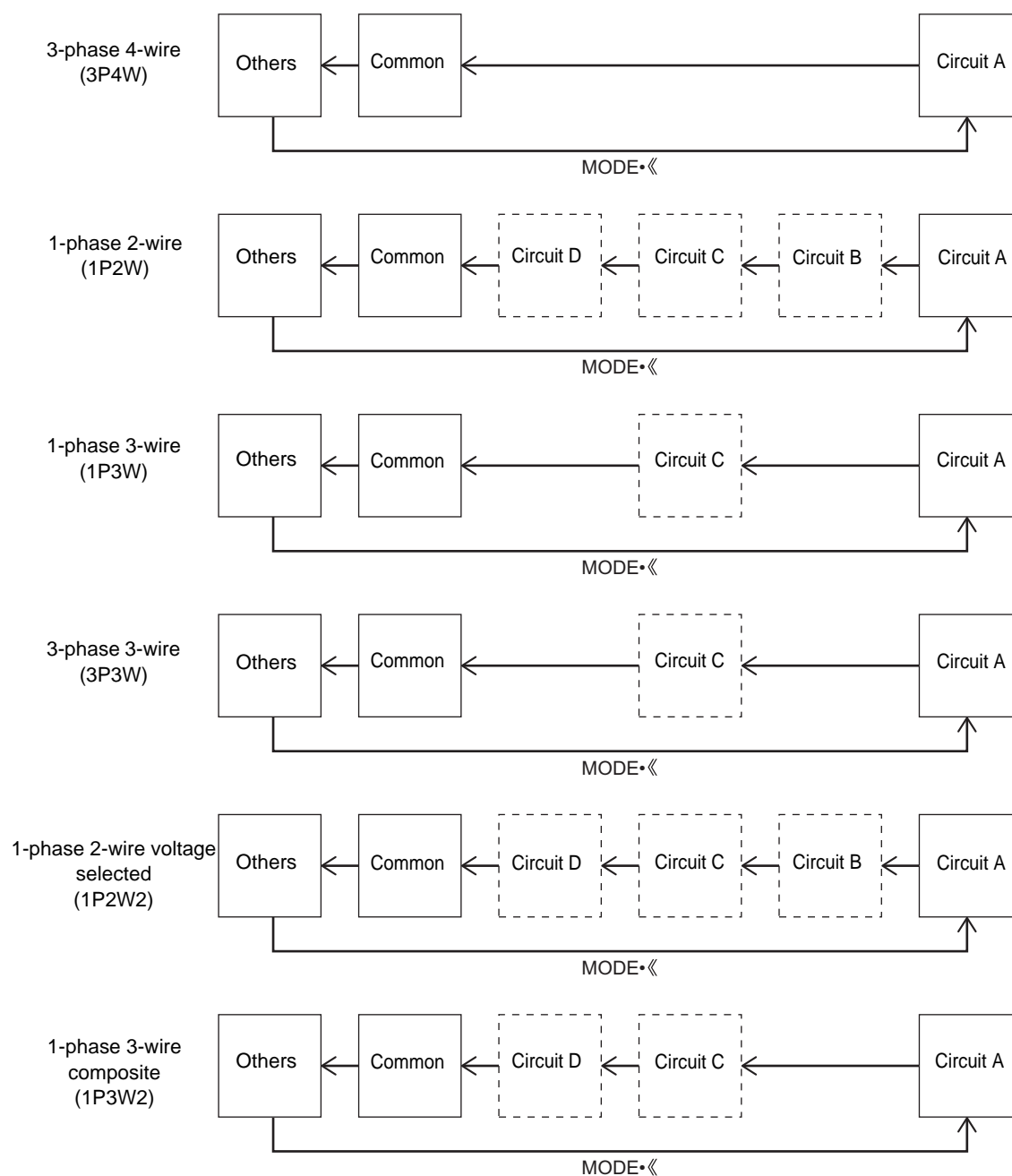

3.4 How to read the setting values (continued)

● How to switch setting items

When the [MODE+<<] key is pressed, the setting items are displayed after the screen for showing the destination circuit.

- The setting items for circuits B to D are displayed when the circuit settings are enabled (ON).
- Press the [↗][↘] keys to switch the setting items.
- Refer to "Setting item list (⇒ 49)" for details about all of the setting items.

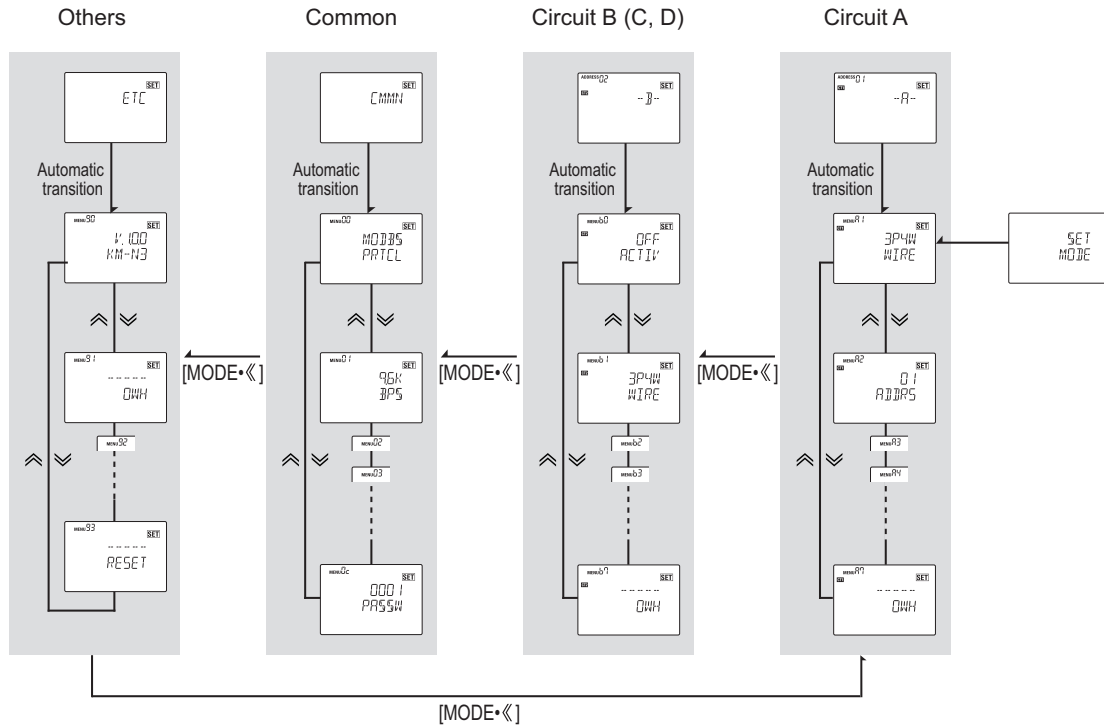

* For circuit C the MENU No. are c0, c1, c2, c3, ... c7
 For circuit D the MENU No. are d0, d1, d2, d3, ... d7

3.4 How to read the setting values (continued)

■ Setting item list

	MENU No.	Setting Item	Main display Display of options and input values	Default Value	Remarks
Circuit A	A1	Phase and wire type	3P4W / 1P2W / 1P3W / 3P3W / 1P2W2 / 1P3W2	3P4W	3P4W: 3-phase 4-wire, 1P2W: 1-phase 2-wire 1P3W: 1-phase 3-wire, 3P3W: 3-phase 3-wire 1P2W2: 1-phase 2-wire voltage selected 1P3W2: 1-phase 3-wire composite
	A2	Communication address	Modbus : --, 01 to 99 CompoWay/F : -- 00 to 99	01	Set a different number for each circuit.
	A3	Current on the CT secondary side	1A / 5A	5A	Set to match the rating of the CT to be used.
	A4	Current on the CT primary side	1 to 99999	5	Rated values for the primary side of the CT to be connected. Set CT individually.
	A5	Voltage assignment	V_R / V_T / V_R-T	V_R	Set the voltage phase for 1-phase 2-wire circuits when 1P2W2 is selected.
	A6	Pulse output ON/OFF	ON / OFF	OFF	
	A7	Active energy reset	-----	-----	Clear the active energy for the circuit.
Circuit B	B0	Circuit B ON/OFF	ON / OFF	OFF	ON: Circuit enabled, measuring and setting possible. OFF: Circuit disabled, measuring and setting not possible.
	B1	Phase and wire type	The phase and wire type set by menu No. A1 is displayed.	/	Phase and wire type set in MENU No. A1
	B2	Communication address	Modbus : --, 01 to 99 CompoWay/F : -- 00 to 99	Automatic S/N	Set a different number for each circuit.
	B3	Current on the CT secondary side	1A / 5A	5A	Set to match the rating of the CT to be used.
	B4	Current on the CT primary side	1 to 9999	5	Rated values for the primary side of the CT to be connected. Set CT individually.
	B5	Voltage assignment	V_R / V_T / V_R-T	V_R	Set the voltage phase for 1-phase 2-wire circuits when 1P2W2 is selected.
	B7	Active energy reset	-----	-----	Clear the active energy for the circuit.
Circuit C	C0	Circuit B ON/OFF	ON / OFF	OFF	ON: Circuit enabled, measuring and setting possible. OFF: Circuit disabled, measuring and setting not possible.
	C1	Phase and wire type	The phase and wire type set by menu No. A1 is displayed.	/	Phase and wire type set in MENU No. A1
	C2	Communication address	Modbus : --, 01 to 99 CompoWay/F : -- 00 to 99	Automatic S/N	Set a different number for each circuit.
	C3	Current on the CT secondary side	1A / 5A	5A	Set to match the rating of the CT to be used.
	C4	Current on the CT primary side	1 to 9999	5	Set CT individually.
	C5	Voltage assignment	V_R / V_T / V_R-T	V_R	Set the voltage phase for 1-phase 2-wire circuits when 1P2W2 or 1P3W2 is selected.
	C7	Active energy reset	-----	-----	Clear the active energy for the circuit.
Circuit D	D0	Circuit B ON/OFF	ON / OFF	OFF	ON: Circuit enabled, measuring and setting possible. OFF: Circuit disabled, measuring and setting not possible.
	D1	Phase and wire type	The phase and wire type set by menu No. A1 is displayed.	/	Phase and wire type set in MENU No. A1
	D2	Communication address	Modbus : --, 01 to 99 CompoWay/F : -- 00 to 99	Automatic S/N	Set a different number for each circuit.
	D3	Current on the CT secondary side	1A / 5A	5A	Set to match the rating of the CT to be used.
	D4	Current on the CT primary side	1 to 9999	5	Set CT individually.
	D5	Voltage assignment	V_R / V_T / V_R-T	V_R	Set the voltage phase for 1-phase 2-wire circuits when 1P2W2 or 1P3W2 is selected.
	D7	Active energy reset	-----	-----	Clear the active energy for the circuit.

3.4 How to read the setting values (continued)

	MENU No.	Setting Item	Main display Display of options and input values	Default Value	Remarks
Common CMMN	00	Protocol	MODBS / COMPF	MODBS	
	01	Communication speed	1.2K / 2.4K / 4.8K 9.6K / 19.2K / 38.4K(bps)	9.6K	
	02	Data length	7 / 8	8	Modbus: 8 (fixed) CompoWay/F: Select between 7 or 8
	03	Stop bit	1 / 2	1	
	04	Parity	NONE / ODD / EVEN	EVEN	
	05	Transmission wait time	00 to 99	20	
	06	VT ratio	1.00 to 999.99	1.00	Set the ratio between the primary voltage and the secondary voltage when voltage using VT is input
	07	Conversion rate	0.000 to 99.999	10.000	Set the conversion factor by which active energy is multiplied for each circuit
	08	Pulse output units	1 / 10 / 100 / 1K / 5K 10K / 50K / 100K (Wh)	100	
	09	Automatic LCD off	OFF / 1.0 / 5.0 / 10.0 (minutes)	OFF	OFF means alight constantly
	0A	Alarm display with negative effective power value ON/OFF	ON / OFF	ON	Set up the alarm display issued when the effective power is negative.
	0B	Tariff ON/OFF	ON / OFF	OFF	
0C	Change password	0000 to 9999	0001	Change the password used when making settings.	
Others ETC	90	Software version display	V.1.0.0		The main display shows an example when the version is 1.0.0.
	91	All active energy reset	----	----	Clear the active energy for all circuits.
	92	Initialize	----	----	Restore the factory defaults. All settings and all measured values are initialized.
	93	Restart	----	----	

4.1 Setting items for measuring electricity

The following are the setting items for measuring electricity.

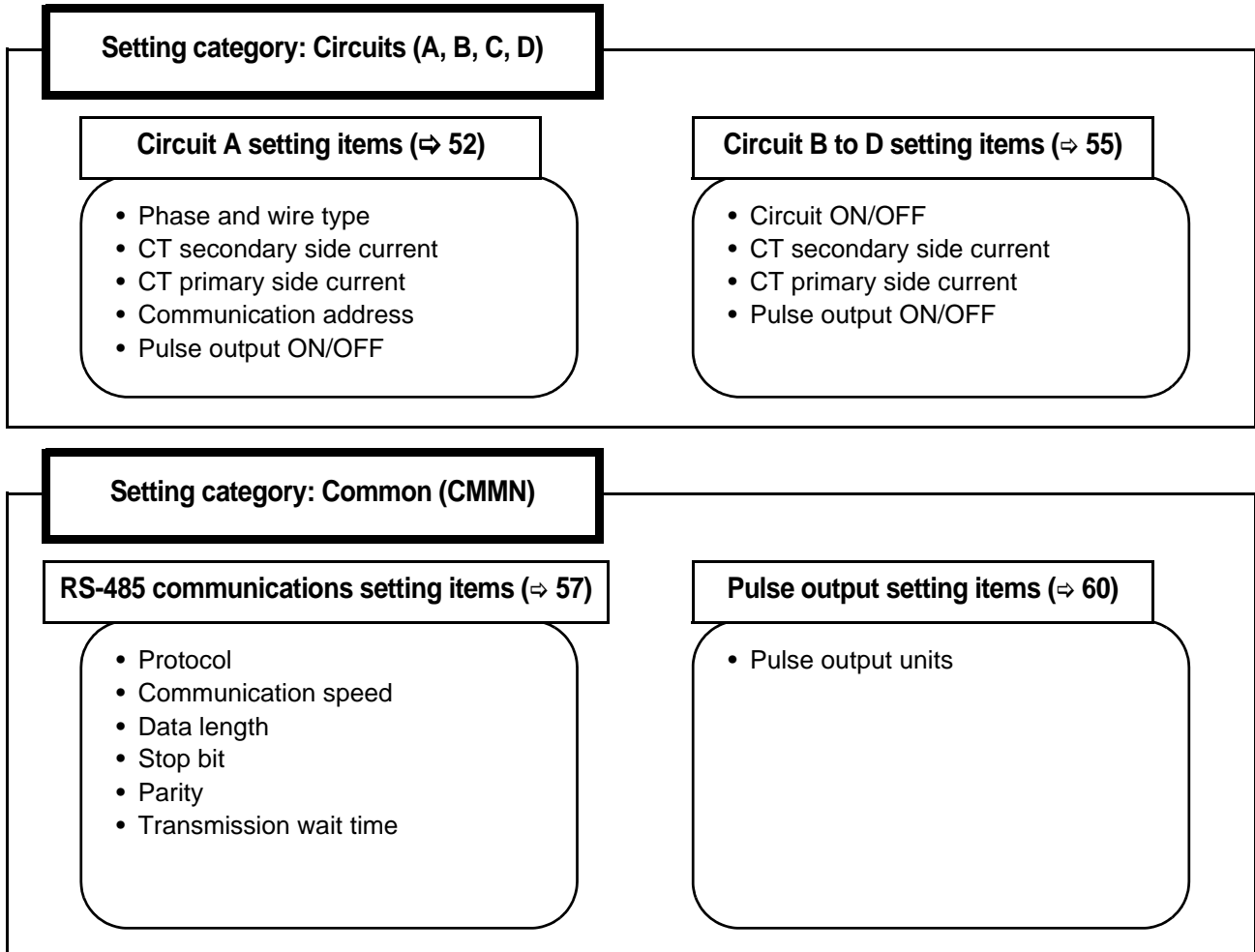

4.2 Circuit settings

Correct measurement requires the correct settings for phase and wire type, CT secondary side, and CT primary side. If points of measurement are added, enable the use of circuits B to D and set them.

● Circuit A settings

The following are the setting items required for measuring with circuit A.
 When RS-485 communication is to be used, set the communication address beforehand (⇒ 53).
 You can cancel a change by pressing the [ESC] key before confirming the change.

1 Moving to setting mode

- 1 After turning on the power, the measuring mode is moved to automatically and the active energy (import) for circuit A is displayed.
- 2 Press and hold the [MODE•◀] key to move from the measuring mode to the password entry screen.
- 3 Press the [↵][⇐] keys and enter the password "0001 (default value)".
 - Press the [MODE•◀] key to move one place to the left.
 - If you press the [MODE•◀] key on the end at the left, the cursor moves to the right end.
- 4 The password is verified when you press the [ENTER] key and "OK" is displayed.
- 5 The screen then moves to the settings mode and the "SET MODE" screen is shown for about 1 second. After the "SET MODE" screen is shown for about 1 second, the screen moves to the settings category display screen for circuit A.



2 Set the phase and wire type (Ex.; set to 1-phase 3-wire)

- 1 Transition from the settings category display screen for circuit A to the settings for circuit A is automatic. "Phase and wire type (MENU A1)" is displayed.
- 2 Press the [ENTER] key to enter the setting mode. The setting value in the main display flashes.
- 3 Press the [↵][⇐] keys to select "1P3W" (1-phase 3-wire).
- 4 Press the [ENTER] key to confirm your selection.

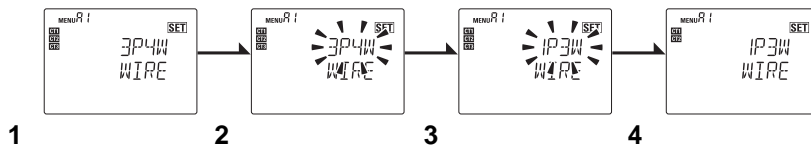

Caution

When the phase and wire type is changed, the enable/disable settings for circuits B to D are switched to "OFF" (disabled).

4.2 Circuit settings (continued)

3 Setting up the communication address (Ex.: set to 15)

- 1 On the setup items of circuit A, press [\curvearrowright] or [\curvearrowleft] key to move to the "Communication address (MENU A2)."
- 2 Press the [ENTER] key to enter the setup mode. The ones place of the main display blinks.
- 3 Press the [\curvearrowright] or [\curvearrowleft] key to change the numerical value to "15."
 - By pressing the [MODE• \curvearrowleft] key, the cursor moves left by one digit.
 - By pressing the [MODE• \curvearrowright] key at the leftmost digit, the cursor moves to the rightmost digit.
- 4 Press the [ENTER] key to determine the settings.

*1. The communication address settings are assigned to circuit A. When multi-address is used, the values on the table below are assigned automatically.

*2. The communication addresses of circuits B-D cannot be set up individually.

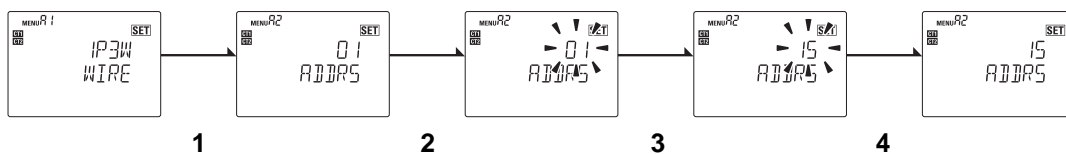

4 Set the CT secondary side current (Ex.: set to 1A)

- 1 From the circuit A setting item, press the [\curvearrowright][\curvearrowleft] keys to move to "CT secondary current (MENU A3)".
- 2 Press the [ENTER] key to enter the setting mode. The setting value in the main display flashes.
- 3 Press the [\curvearrowright][\curvearrowleft] keys to select "1A".
- 4 Press the [ENTER] key to confirm your selection.

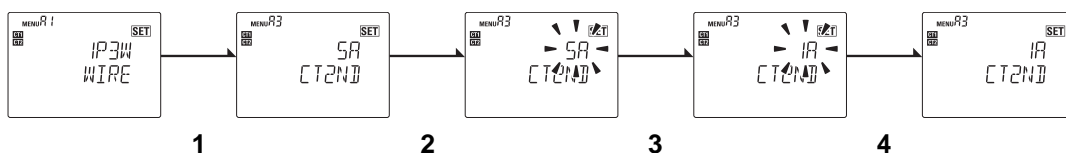

5 Set the CT primary side current (Ex.: set to 50A)

- 1 From the circuit A setting item, press the [\curvearrowright][\curvearrowleft] keys to move to "CT primary current (MENU A4)".
- 2 Press the [ENTER] key to enter the setting mode.
- 3 Press the [\curvearrowright][\curvearrowleft] keys to change the value to "50".
 - Press the [MODE• \curvearrowleft] key to move one place to the left.
 - If you press the [MODE• \curvearrowleft] key on the end at the left, the cursor moves to the right end.
- 4 Press the [ENTER] key to confirm your change.

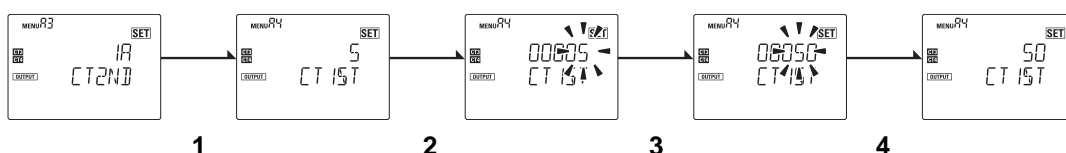

4.2 Circuit settings (continued)

6 Set pulse output ON or OFF(MENU A6) (Ex.: set to ON)

- 1 From the circuit A setting item, press the [\curvearrowright][\curvearrowleft] keys to move to "Pulse output ON/OFF (MENU A6)".
- 2 Press the [ENTER] key to enter the setting mode.
- 3 Press the [\curvearrowright][\curvearrowleft] keys to select "ON".
- 4 Press the [ENTER] key to confirm your selection.

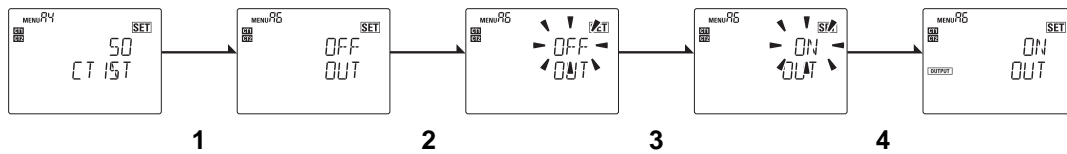

4.2 Circuit settings (continued)

● Settings for circuits B to D (when measuring 2 circuits or more)

This product can measure up to 4 circuits. If you increase the number of circuits, you must enable the circuits and set the items for them. (⇒ 20) Make sure you disable those circuits you are not using.

You cannot set the communications addresses for circuits B to D individually. It is set automatically as follows based on the setup values of circuit A.

Phase and wire type	Communication address			
	Circuit A	Circuit B	Circuit C	Circuit D
3-phase 4-wire	Setup values by MENU A2	—	—	—
1-phase 2-wire		(Value of Circuit A +1)	(Value of Circuit A +2)	(Value of Circuit A +3)
1-phase 3-wire		—	(Value of Circuit A +1)	—
3-phase 3-wire		—	(Value of Circuit A +1)	—
1-phase 2-wire voltage selected		(Value of Circuit A +1)	(Value of Circuit A +2)	(Value of Circuit A +3)
1-phase 3-wire composite		—	(Value of Circuit A +1)	(Value of Circuit A +2)

Caution

- A communication address greater than 99 is invalid.

1 Enable just those circuits from B to D that will be used (Ex.: enable circuit C)

If a measured value is displayed, press and hold the [MODE•◀] key and enter your password to switch to the setting mode.

- 1 Press the [MODE•◀] key to move to the settings category display screen for circuit C.
"Circuit C ON/OFF (MENU C0)" is displayed.
- 2 Press the [ENTER] key to enter the setting mode.
- 3 Press the [↵][⏏] keys to select "ON".
- 4 Press the [ENTER] key to confirm your selection.

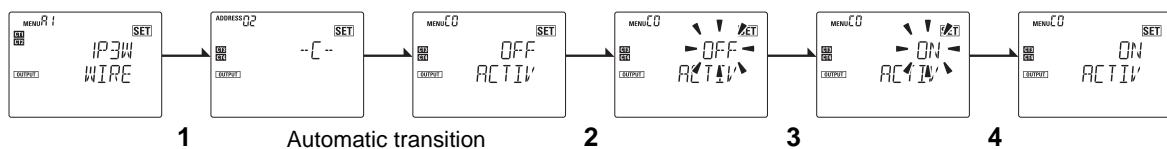

2 Set the CT secondary current for the circuits enabled from B to D (Ex.: set the CT secondary current for circuit C to 1A)

- 1 From the circuit C setting item, press the [↵][⏏] keys to move to "CT secondary current (MENU C3)".
- 2 Press the [ENTER] key to enter the setting mode. The setting value in the main display flashes.
- 3 Press the [↵][⏏] keys to select "1A".
- 4 Press the [ENTER] key to confirm your selection.

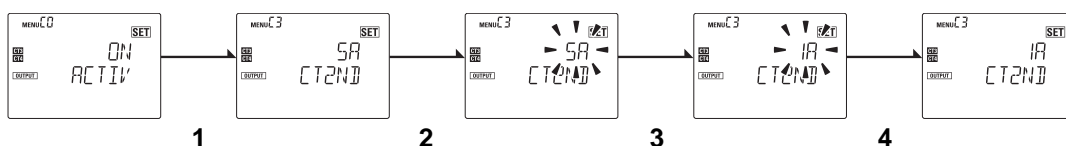

4.2 Circuit settings (continued)

3 Set the CT primary current for the circuits enabled from B to D (Ex.: set the CT primary current for circuit C to 50A)

- 1 From the circuit C setting item, press the [↵][⇩] keys to move to "CT primary current (MENU C4)".
- 2 Press the [ENTER] key to enter the setting mode.
- 3 Press the [↵][⇩] keys to change the value to "50".
 - Press the [MODE•◀] key to move one place to the left.
 - If you press the [MODE•◀◀] key on the end at the left, the cursor moves to the right end.
- 4 Press the [ENTER] key to confirm your selection.

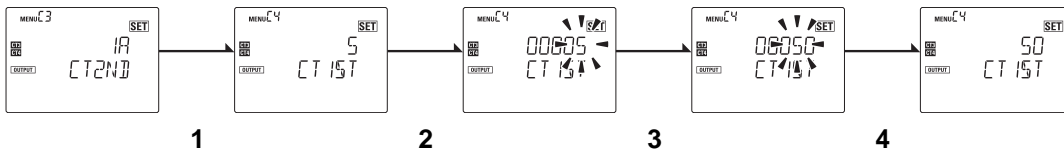

4 Set pulse output ON or OFF (MENU C6) (Ex.: set circuit C to ON)

- 1 From the circuit C setting item, press the [↵][⇩] keys to move to "Pulse output ON/OFF (MENU C6)".
- 2 Press the [ENTER] key to enter the setting mode.
- 3 Press the [↵][⇩] keys to select "ON".
- 4 Press the [ENTER] key to confirm your selection.

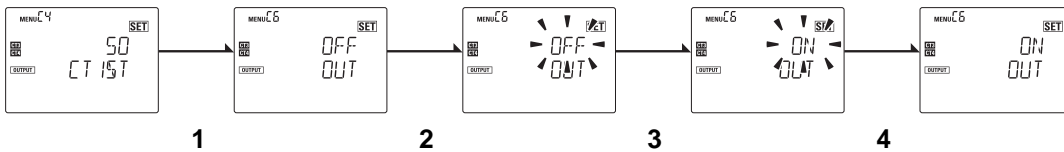

The menu numbers to assign the pulse output terminals of circuits B-D are B6 for circuit B, C6 for circuit C, and D6 for circuit D.

Caution

- The phase and wire type is set in circuit A. The phase and wire type set for circuit A is shown in the circuit B to D setting items (MENU B1, C1, and D1) and cannot be changed.
- Depending on the phase and wire type set for circuit A, there will be circuits that are unavailable for use. The setting items for circuits unavailable for use will not be displayed.
- You need to set the current for the CT secondary side and CT primary side for each circuit. Confirm the rated values for the CT you are using and set correctly.

4.3 RS-485 communication settings

For communications settings other than the communications address, set in the common settings in the settings mode. All circuits will have the same setting.

- You can cancel a change by pressing the [ESC] key before confirming the change.

■ Set the protocol (Ex.: set to CompoWay/F)

This unit support the Modbus and CompoWay/F communications protocols. The initial setting is Modbus.

If a measured value is displayed, press and hold the [←/MODE] key and enter your password to switch to the setting mode.

- Press the [MODE•←] key to move to the common settings "CMMN" category display screen. After this, the screen moves automatically to the common settings items and "Protocol (MENU 00)" is displayed.
- Press the [ENTER] key to enter the setting mode.
- Press the [↵][⇩] keys to select "COMPF".
- Press the [ENTER] key to confirm your selection.

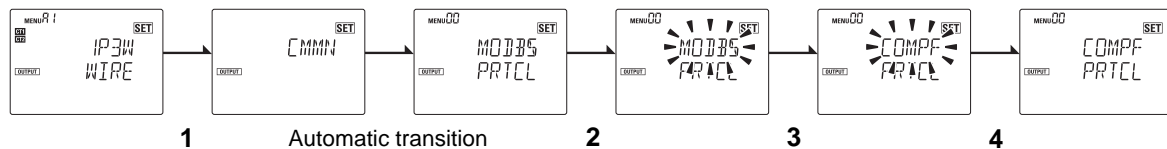

■ Set the communication speed (Ex.: set to 38.4 kbps)

- Press the [MODE•←] key to move to the common settings "CMMN" category display screen.
- From the common setting items, press the [↵][⇩] keys to move to "Communication speed (MENU 01)".
- Press the [ENTER] key to enter the setting mode.
- Press the [↵][⇩] keys to select "38.4K".
- Press the [ENTER] key to confirm your selection.

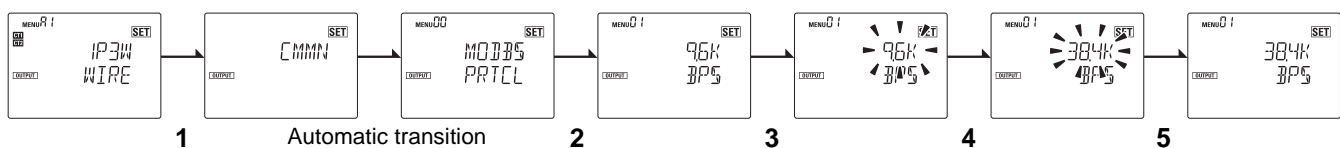

4.3 RS-485 communication settings (continued)

■ Set the data bit length (Ex.: set to 7 bits)

Can only be set when the protocol is CompoWay/F.

- 1 Press the [MODE•◀] key to move to the common settings "CMMN" category display screen.
- 2 From the common setting items, press the [↵][≡] keys to move to "Data length (MENU 02)".
- 3 Press the [ENTER] key to enter the setting mode.
- 4 Press the [↵][≡] keys to select "7".
- 5 Press the [ENTER] key to confirm your selection.

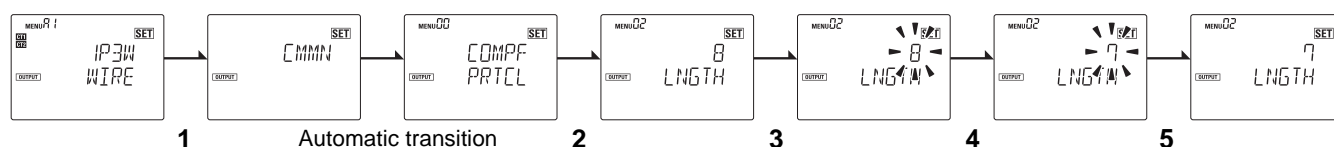

Caution

- If the protocol is Modbus, the data bit length is fixed at 8bits.

■ Set the stop bit length (Ex.: set to 2 bits)

Can only be set when the protocol is CompoWay/F.

- 1 Press the [MODE•◀] key to move to the common settings "CMMN" category display screen.
- 2 From the common setting items, press the [↵][≡] keys to move to "Stop bit length (MENU 03)".
- 3 Press the [ENTER] key to enter the setting mode.
- 4 Press the [↵][≡] keys to select "2".
- 5 Press the [ENTER] key to confirm your selection.

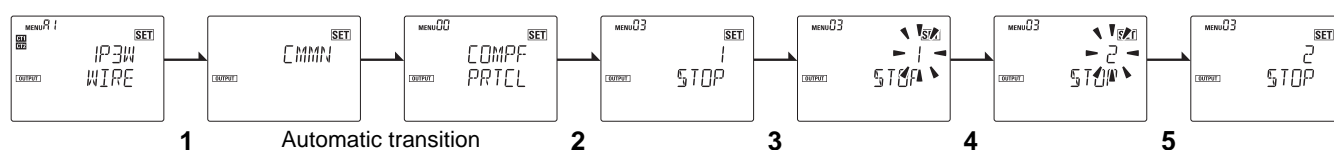

Caution

- If the protocol is Modbus, then the stop bit length is automatically set according to the vertical parity setting (⇒ 59) as follows:
 - "2" if the vertical parity is "NONE"
 - "1" if the vertical parity is "ODD" or "EVEN"

4.3 RS-485 communication settings (continued)

■ Set the vertical parity (Ex.: set to ODD)

Select "NONE" for no parity, "EVEN" for even parity, and "ODD" for odd parity.

- 1 Press the [MODE•◀] key to move to the common settings "CMMN" category display screen.
- 2 From the common setting items, press the [↵][⇐] keys to move to "Parity (MENU 04)".
- 3 Press the [ENTER] key to enter the setting mode.
- 4 Press the [↵][⇐] keys to select "ODD".
- 5 Press the [ENTER] key to confirm your selection.

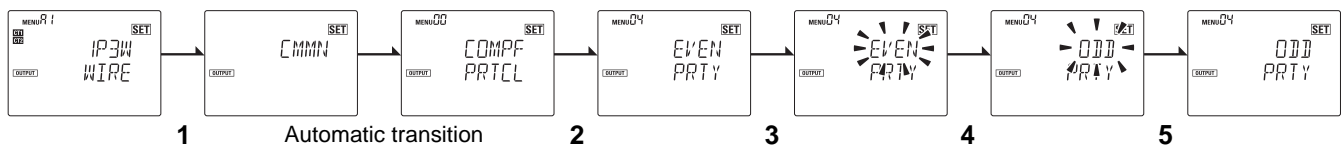

■ Set the transmission wait time (Ex.: set to 15 msec)

You can set the time to wait between when a response is created and when it is sent. The setting can be changed in units of 1ms. The default value is 20ms.

- 1 Press the [MODE•◀] key to move to the common settings "CMMN" category display screen.
- 2 From the common setting items, press the [↵][⇐] keys to move to "Transmission wait time (MENU 05)".
- 3 Press the [ENTER] key to enter the setting mode.
- 4 Press the [↵][⇐] keys to change the value to "15".
 - Press the [MODE•◀] key to move one place to the left.
 - If you press the [MODE•◀] key on the end at the left, the cursor moves to the right end.
- 5 Press the [ENTER] key to confirm your change.

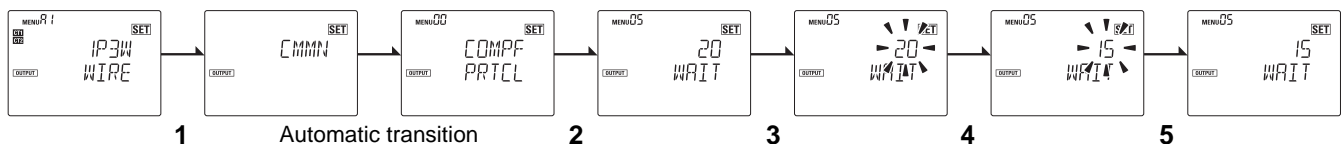

4.4 Pulse output settings

This product has 4 pulse output ports (OUT1, OUT2, OUT3, OUT4). You can set output ON or OFF for each output port in the pulse output settings.

When the active energy exceeds the output units, a pulse wave is output from the ports for which pulse output is set to ON.

The following diagram shows pulse output waveforms. The ON output width is fixed at 500ms. The OFF sustained width after output is 100ms.

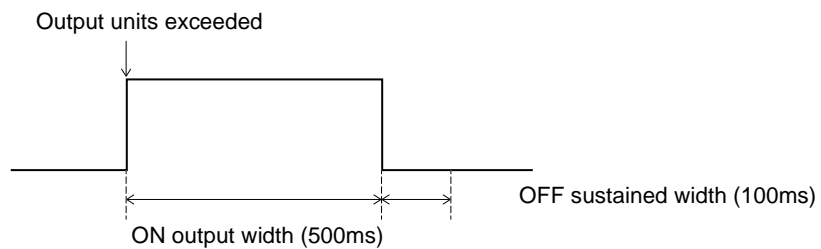

Basic pulse output waveform

An alarm is displayed when there is a pulse output error (⇒ 100). A pulse output error may be either of the following states.

- The output unit is exceeded again while still in the ON output state.
Action when error occurs: The pulse output continues for more than 500ms due to the unit being exceeded again.
- Output unit is exceeded within the OFF sustained width.
Action when error occurs: Pulse is output within the time of the OFF sustained width.

■ Set the pulse output units (Ex.: set to 10kWh/pulse)

Pulse output units settings are common to all ports. The default value is 100Wh/pulse. You can cancel a change by pressing the [ESC] key before confirming the change.

- 1 Press the [MODE] key to move to the common settings "CMMN" category display screen.
- 2 From the common setting items, press the [↵][⇐] keys to move to "Pulse output units (MENU 08)".
- 3 Press the [ENTER] key to enter the setting mode.
- 4 Press the [↵][⇐] keys to select "10k".
- 5 Press the [ENTER] key to confirm your selection.

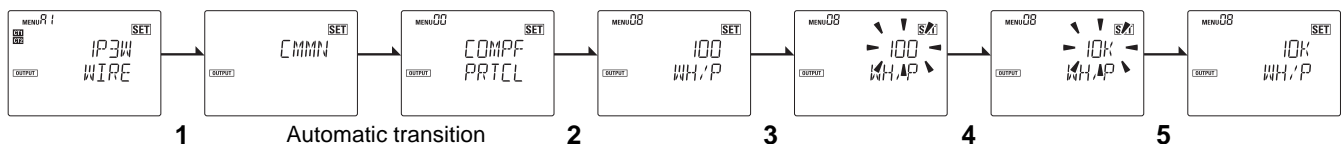

5.1 Voltage assignment

If the phase and wire type has been set to 1-phase 2-wire voltage selected (1P2W2) or 1-phase 3-wire composite (1P3W2), then you need to set the voltage for the 1-phase 2-wire circuit doing the measuring. Set either R-N phase or T-N phase if the input voltage is AC100V, and set R-T phase of the input voltage is AC200V.

As the following diagram shows, the 1-phase 2-wire circuit for which the voltage allocation is set is circuit A, circuit B, circuit C, and circuit D for 1P2W2 wiring and circuit C and circuit D in the 1P3W2 wiring diagram.

You need to allocate voltage for each circuit.

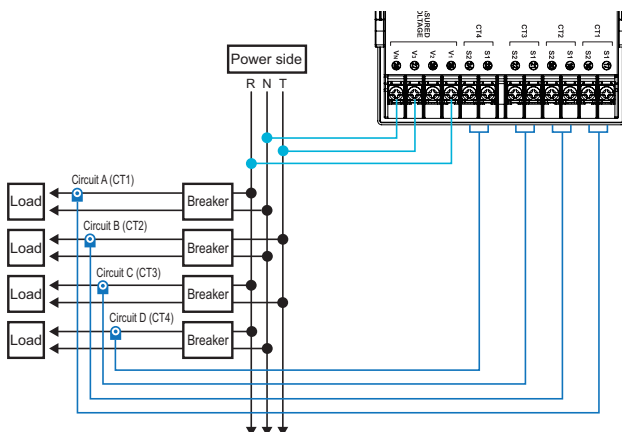

Wiring diagram for 1-phase 2-wire voltage selected

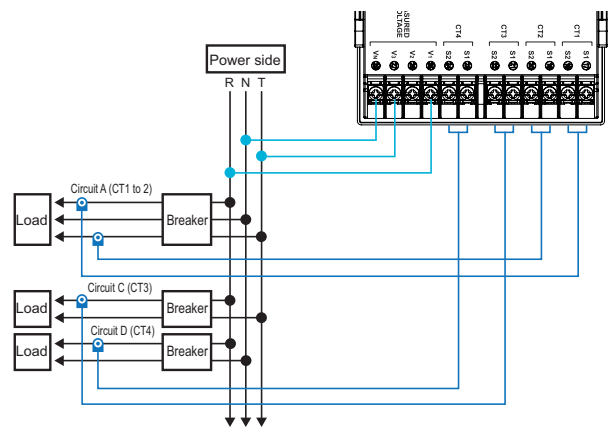

Wiring diagram for 1-phase 3-wire composite

■ Set the voltage assignment (Ex.: set the voltage assignment for circuit C to V_R-T)

If a measured value is displayed, press and hold the [MODE•<<] key and enter your password to switch to the setting mode.

- 1 Press the [MODE•<<] key to move to the settings category display screen for circuit C.
- 2 From the circuit C setting item, press the [↗][↘] keys to move to "Voltage assignment (MENU C5)".
- 3 Press the [ENTER] key to enter the setting mode.
- 4 Press the [↗][↘] keys to select "V_R-T".
- 5 Press the [ENTER] key to confirm your selection.

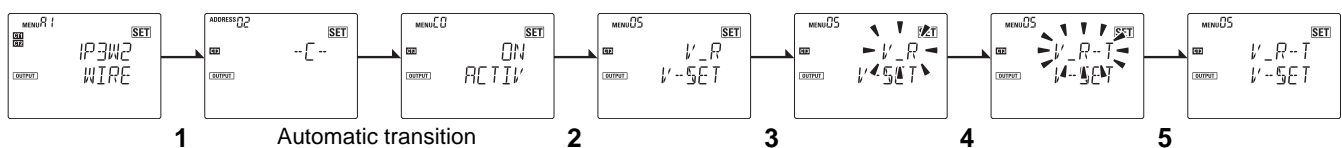

Information

- The MENU No. for allocating voltage for circuit A is "A5".
- The MENU No. for allocating voltage for circuits B to D are circuit B "B5", circuit C "C5", and circuit D "D5".

5.2 Measuring high voltage

If the line voltage measured is 480V or more, for example, measuring 6,600V in the cubicle, use a transformer to convert the line voltage within the input voltage range of this product. Set the multiplication factor from the primary voltage value and the secondary voltage value. For example, if the primary voltage is 880V and the secondary voltage is 110V, this becomes $880/110=8.00$.

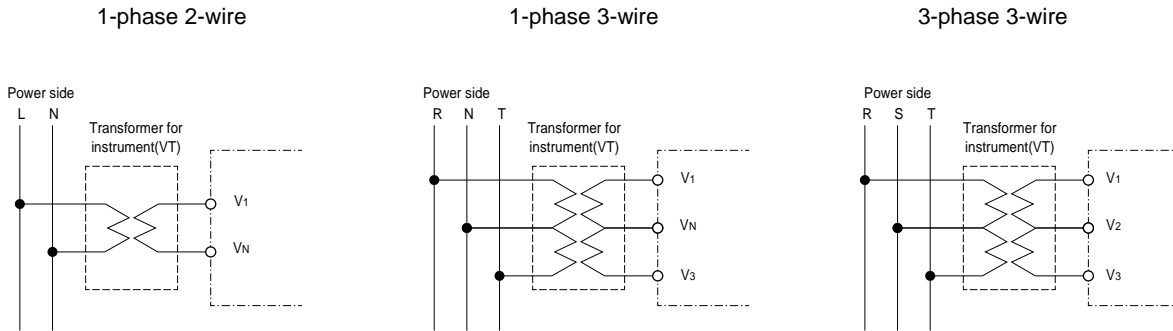

■ Set the VT ratio (Ex.: set to 8.00)

If a measured value is displayed, press and hold the [MODE•◀] key and enter your password to switch to the setting mode.

- 1 Press the [MODE•◀] key to move to the common settings "CMMN" category display screen.
- 2 From the common setting items, press the [↵][≡] keys to move to "VT ratio (MENU 06)".
- 3 Press the [ENTER] key to enter the setting mode. The second decimal place of the setting value in the main display flashes.
- 4 Press the [↵][≡] keys to change the value to "8.00".
 - Press the [MODE•◀] key to move one place to the left.
 - If you press the [MODE•◀] key on the end at the left, the cursor moves to the right end.
- 5 Press the [ENTER] key to confirm your change.

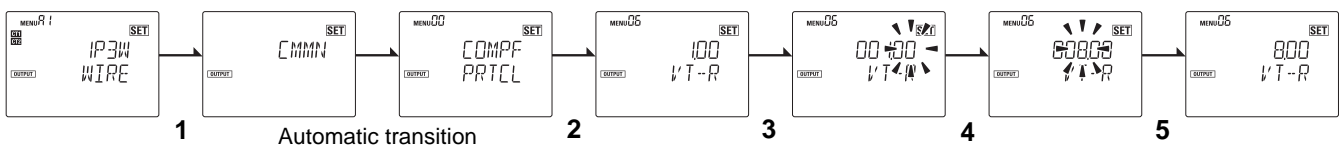

Caution

- When measuring voltage under 480V, accuracy can be improved by directly entering the voltage rather than by using a transformer.

5.3 Display unit conversion

You can display a value calculated by multiplying the integrated electric energy of each circuit by a specified coefficient. You can convert the active energy to a monetary figure or volume of CO₂.

■ Set the conversion rate (Ex.: set to 0.300)

If a measured value is displayed, press and hold the [MODE•◀] key and enter your password to switch to the setting mode.

- 1 Press the [MODE•◀] key to move to the common settings "CMMN" category display screen.
- 2 From the common setting items, press the [↵][⇐] keys to move to "Conversion rate (MENU 07)".
- 3 Press the [ENTER] key to enter the setting mode. The third decimal place of the setting value in the main display flashes. The decimal point cannot be changed.
- 4 Press the [↵][⇐] keys to change the value to "0.300".
 - Press the [MODE•◀] key to move one place to the left.
 - If you press the [MODE•◀] key on the end at the left, the cursor moves to the right end.
- 5 Press the [ENTER] key to confirm your change.

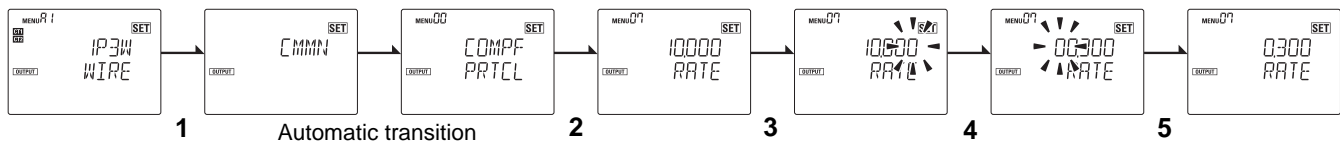

5.4 Automatic LCD OFF

This feature turns the LCD display off after the set time elapses. When the LCD is off, it can be turned on again by operating any key. When Automatic LCD OFF is turned OFF, the LCD display is always lighting.

■ Set the automatic LCD off time (Ex.: set to 10 minutes)

If a measured value is displayed, press and hold the [MODE•◀] key and enter your password to switch to the setting mode.

- 1 Press the [MODE•◀] key to move to the common settings "CMMN" category display screen.
- 2 From the common setting items, press the [↵][↵] keys to move to "Automatic LCD off (MENU 09)".
- 3 Press the [ENTER] key to enter the setting mode.
- 4 Press the [↵][↵] keys to select "10.0".
- 5 Press the [ENTER] key to confirm your selection.

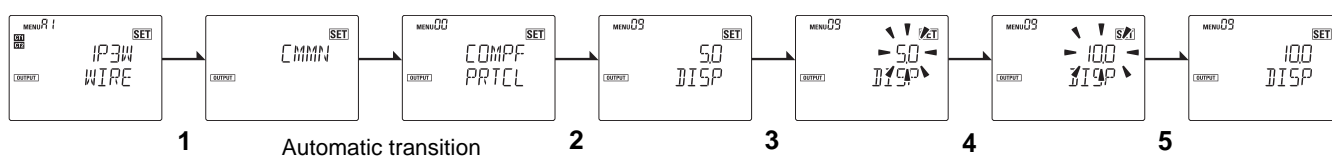

5.5 Alarm display with negative effective power value

This is a function to display an alarm if effective power becomes a negative value. (⇒ 100).

- If the phase of the voltage and current differ and the active power is a negative value, the error is "Active power is a negative value".

Information

- The alarm display is cancelled by starting up the product again after the wiring and input are corrected.

■ Set the alarm display with negative effective power value (Ex.; set to OFF)

If a measured value is displayed, press and hold the [MODE•◀] key and enter your password to switch to the setting mode.

- 1 Press the [MODE•◀] key to move to the common settings "CMMN" category display screen.
- 2 From the common setting items, press the [↗][↘] keys to move to "Alarm display with negative effective power value ON/OFF (MENU 0A)".
- 3 Press the [ENTER] key to enter the setting mode.
- 4 Press the [↗][↘] keys to select "OFF".
- 5 Press the [ENTER] key to confirm your selection.

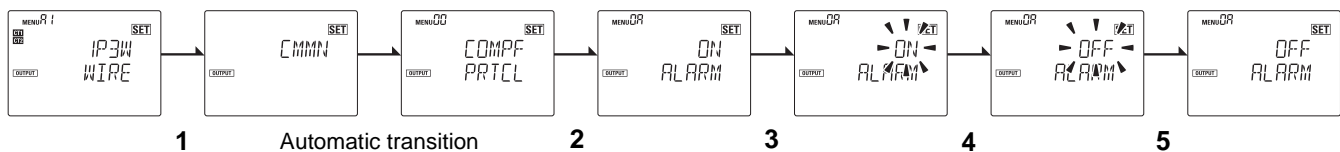

5.6 Tariff feature

This feature allows you to select a location to save cumulative active energy data from T1 to T4.

Using the tariff feature allows you to, for example, change the location to save active energy so that you can later on check the sum of active energy during a particular time period (for example, night and day when the electricity charges are different).

- The current tariff default value is T1.
- The value for the current tariff can only be changed from the communication settings (⇒ 72).

■ Set the tariff function (Ex.: set to ON)

If a measured value is displayed, press and hold the [MODE•◀] key and enter your password to switch to the setting mode.

- 1 Press the [MODE•◀] key to move to the common settings "CMMN" category display screen.
- 2 From the common setting items, press the [↵][⇩] keys to move to "Tariff ON/OFF (MENU 0C)".
- 3 Press the [ENTER] key to enter the setting mode.
- 4 Press the [↵][⇩] keys to select "ON".
- 5 Press the [ENTER] key to confirm your selection.

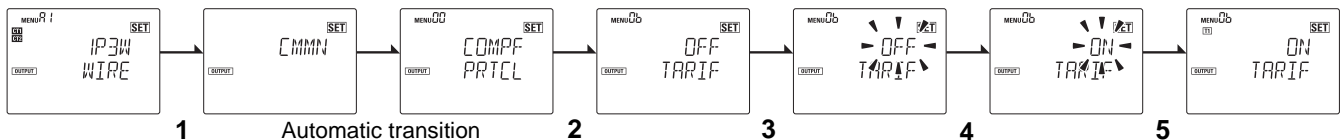

5.7 Change password

- This enables you to change the password that you need to enter when moving from the measuring mode to the setting mode.
- You can set a password of 4 numerals between 0000 and 9999.
- The default password is "0001".
- There is no functionality to disable the password setting.

■ Set the password (Ex.: set to 3060)

If a measured value is displayed, press and hold the [MODE•◀] key and enter your password to switch to the setting mode.

- 1 Press the [MODE•◀] key to move to the common settings "CMMN" category display screen.
- 2 From the common setting items, press the [↵][↵] keys to move to "Change password (MENU 0C)".
- 3 Press the [ENTER] key to enter the setting mode.
- 4 Press the [↵][↵] keys to change to "3060".
 - Press the [MODE•◀] key to move one place to the left.
 - If you press the [MODE•◀] key on the end at the left, the cursor moves to the right end.
- 5 "ONCE AGAIN" is displayed when you press the [ENTER] key.
- 6 The screen to enter the password the second time is displayed.
- 7 Input the password you entered in 4 (3060) again.
- 8 "OK" is displayed when you press the [ENTER] key, the display transitions to the "Change password (MENU 0C)" display, and the password has been changed successfully.

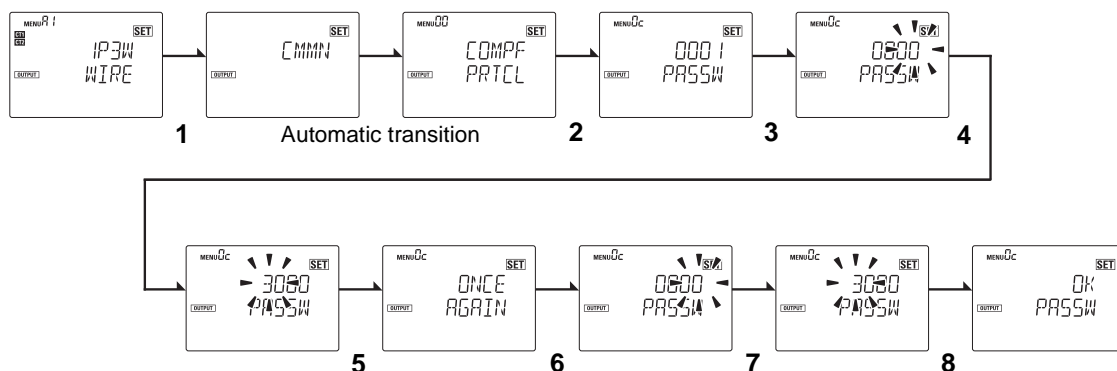

NG is displayed if the password you entered the first time and the second time are different, and the display returns to "Change password (MENU 0C)".

Change the password again.



Important

- You will be unable to reset the password if you forget it. Take care to note the password carefully when changing it.
- If you forget the password, contact the place of purchase or the manufacturer.

5.8 Checking software version

You can check the version of software this product is using.

■ Checking software version

If a measured value is displayed, press and hold the [MODE•◀] key and enter your password to switch to the setting mode.

- 1 Press the [MODE•◀] key to move to the other settings "ETC" category display screen.
Next, the display automatically transitions to the "Check software version (MENU 90)" screen, displaying the software version on the upper line and the product model on the lower line.

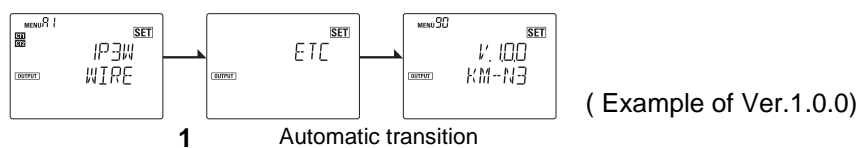

5.9 Initialize

There are three different types of initialization.

- (1) Resetting the active energy for each circuit
- (2) Resetting the active energy for all circuits
- (3) Resetting the active energy and setting values for all circuits

- Setting values remain unchanged if you do either (1) or (2).
- The settings for each of the circuits are also reset if you do (3). The unit restarts after you do this.
- Only the integrated electric energy which can be reset is initialized.

■ Resetting the active energy for each circuit (example: resetting circuit A)

If a measured value is displayed, press and hold the [MODE•◀] key and enter your password to switch to the setting mode.

- 1 From the circuit A setting items, press the [↗][↘] keys to move to "Active energy reset (MENU A7)".
- 2 When you press and hold the [ENTER] key, the dashes (-) reduce from the left side of the main screen.
- 3 Keep pressing the [ENTER] key.
- 4 When the dashes (-) disappear, and "DONE" flashes on the screen, the active energy for Circuit A has been reset.

After completing initialization, "MENU 07" is displayed again.

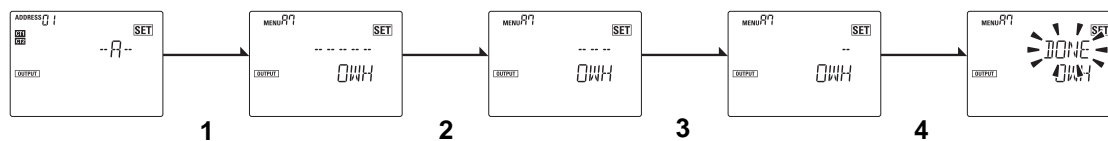

Information

- The MENU No. for resetting active energy values for circuits B to D are circuit B "B7", circuit C "C7", and circuit D "D7".

5.9 Initialize (continued)

■ Resetting the active energy for all circuits

If a measured value is displayed, press and hold the [MODE•◀] key and enter your password to switch to the setting mode.

- 1 Press the [MODE•◀] key to move to the other settings "ETC" category display screen.
- 2 From the other setting items, press the [▲][▼] keys to move to "All active energy reset (MENU 91)".
- 3 When you press and hold the [ENTER] key, the dashes (-) reduce from the left side of the main screen.
- 4 Keep pressing the [ENTER] key.
- 5 When the dash (-) disappears, and "DONE" flashes on the screen, the active energy for all circuits has been reset.

After completing initialization, "MENU 91" is displayed again.

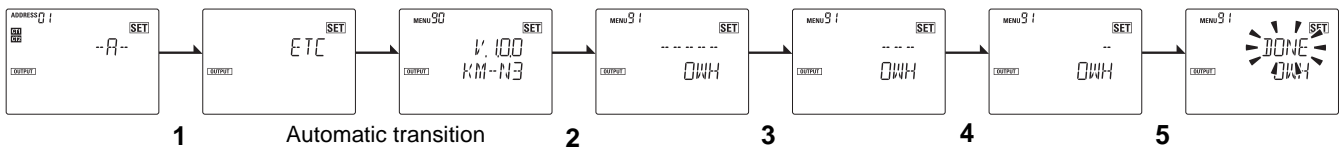

■ Resetting the active energy and setting values for all circuits

If a measured value is displayed, press and hold the [MODE•◀] key and enter your password to switch to the setting mode.

- 1 Press the [MODE•◀] key to move to the other settings "ETC" category display screen.
- 2 From the other setting items, press the [▲][▼] keys to move to "Initialize (MENU 92)".
- 3 When you press and hold the [ENTER] key, the dashes (-) reduce from the left side of the main screen.
- 4 Keep pressing the [ENTER] key.
- 5 When the dash (-) disappears, and "DONE" flashes on the screen, the active energy and setting values for all circuits has been reset.

After initializing, press and hold the [MODE•◀] key to move to the measuring mode and restart the unit.

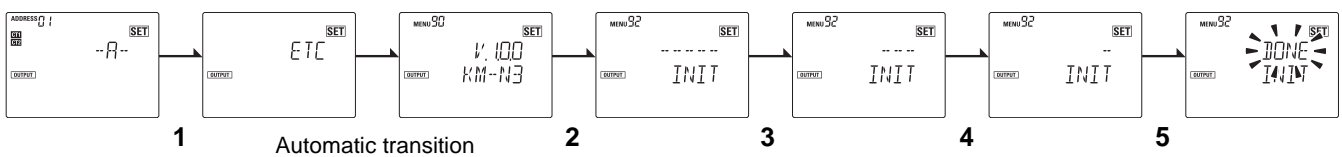

Information

- You can cancel the reset by pressing [ESC] before "DONE" is displayed.

5.10 Restart

Restart this product.

■ Restarting

If a measured value is displayed, press and hold the [MODE•◀] key to enter a password to move to the setup mode.

- 1 Press the [MODE•◀] key to move to the other settings "ETC" category display screen.
- 2 From the other setting items, press the [▲][▼] keys to move to "Restart (MENU 93)".
- 3 When you press and hold the [ENTER] key, the dashes (-) reduce from the left side of the main screen.
- 4 Keep pressing the [ENTER] key.
- 5 When the dash (-) disappears, and "DONE" flashes on the screen, the product is restarted.

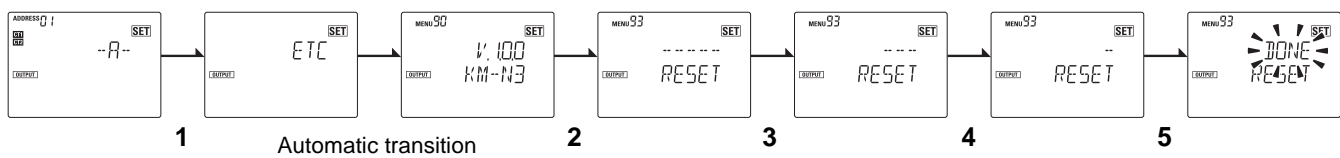

Information

- You can cancel the reset by pressing [ESC] before "DONE" is displayed.

6.1 Overview of communications

Using the communications features enables you to create programs on host devices (such as computers) to collect the data measured by this product and to change its settings.

Each circuit on this product is allocated different communications addresses (numbered in order).

(⇒ 22) Even if you connect several of these products on the same RS-485 line, all of the circuits need to be allocated different communications addresses. (⇒ 57)

Circuits are identified by their communications addresses. These are indicated in the address maps in "6.4 Address map (⇒ 96)" and the addresses for each circuit are all the same.

You can use the Modbus and CompoWay/F protocols for communication.

■ Communications specifications

Communications protocols	Modbus	CompoWay/F
Transmission connections	Multi-drop (1:N connection)	
Communication system	2 line half duplex	
Sync method	Asynchronous	
Baud rate	2.4, 4.8, <u>9.6</u> , 19.2, 38.4kbps	
Transfer code	Binary	ASCII
Data bit length	<u>8 bits (fixed)</u>	7 or 8 bits
Stop bit length	With parity: <u>1 bit</u> Without parity: 2 bits	1 or 2 bits
Error detection	Vertical parity (none, <u>odd</u> , even) Check code: CRC-16	Vertical parity (none, odd, even) Check code: BCC
Flow control	None	
Interface	RS-485	
Retry function	None	
Communication response Transmission wait time	0 to 99 (ms), <u>Default 20 (ms)</u>	
Transmission buffer	230 (byte)	

* Default values are underlined.

■ Transmission procedure

The host device (a computer, for example) sends the command frame and model KM-N3 sends the response frame that corresponds to the command content. So 1 response frame is sent in response to one command frame. The command frame and response frame act as follows.

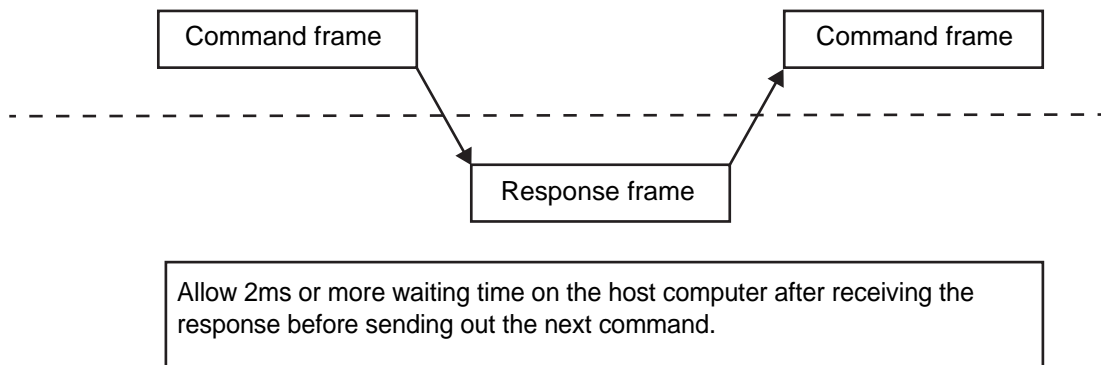

6.2 Modbus

● Data format

In the following explanations, values preceded by H' (as in H'02) indicate hexadecimal values. The numbers under the frame sections are the number of bytes. Also, the transfer code is binary for Modbus.

■ Command frame

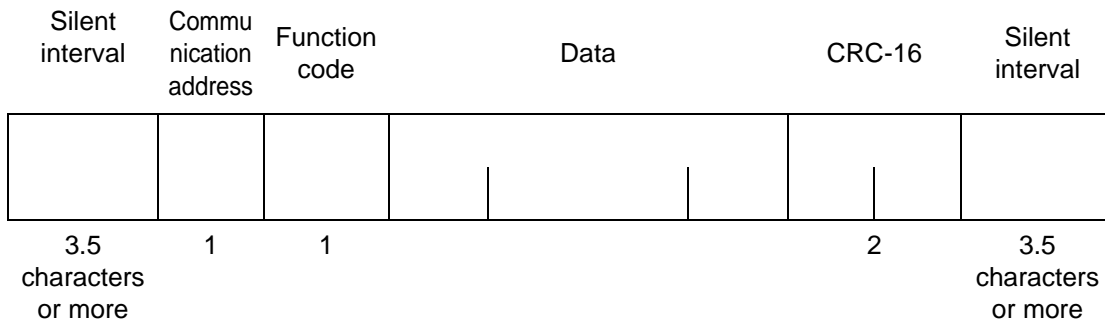

Silent interval	A non-communication time of 3.5 characters worth of time or more
Communication address	<ul style="list-style-type: none"> Specifies the "Communication address" of this product. Figures in hexadecimal format between H'01 to H'63 (01 to 99) can be set. Specify H'00 to communicate to all at the same time. There will be no response if this is specified however.
Function code	Code to indicate the type of command.
Data	Data text to match the function code.
CRC-16	Cyclical Redundancy Check This check code is for the communication address until the end of the data.

■ Response frame when normal

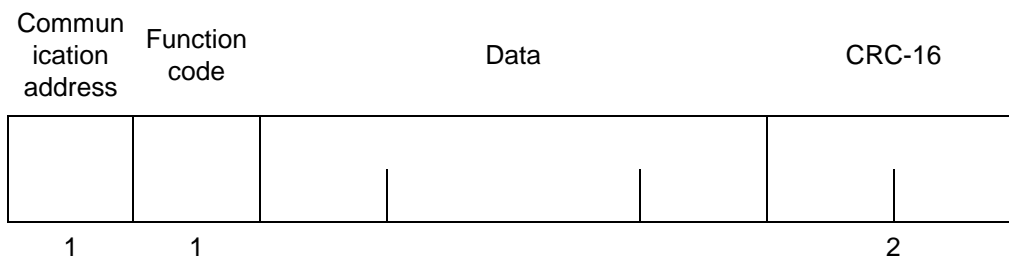

Communication address	The number specified by the command from is inserted as is. The communication address that returned the response.
Function code	Function code that was received.
Data	Data received.
CRC-16	Cyclical Redundancy Check This check code is for the communication address until the end of the data.

6.2 Modbus (continued)

■ Response frame when there is an error

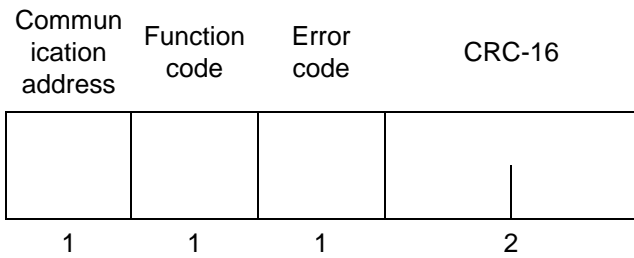

Communication address	The number specified by the command from is inserted as is. This is the communication address that returned the response.
Function code	In the response frame when an error occurs, the addition of "H'80" to the received function code indicates that it is an error response. For example: If the response is H'03 normally, then a response when there is an error would be H'83.
Error code	An exit code to describe an error.
CRC-16	Cyclical Redundancy Check This check code is for the communication address until the end of the data.

■ An example for CRC-16 calculation

The work for calculation (16 bit register: CRC register hereunder) is processed byte by byte in the message.

- 1 Make the initial value of the CRC register H'FFFF
- 2 Use an XOR on the lower 8 bits of the CRC register and the first byte of data, return that result to the CRC register.
- 3 While embedding the "0", move the CRC register 1 bit to the right.
- 4 If the bit shifted from the LSB is "0", repeat step 3 (the following bit shift process). If the bit shifted from the LSB is a "1", use an XOR calculation on the CRC register and H'A001, returning that result to the CRC register
- 5 Repeat steps 3 and 4 until 8 bits worth of data has been shifted
- 6 If the end of the message is not reached, use an XOR on the CRC register and the next byte of data, return that result to the CRC register and repeat step 3
- 7 The calculated result (the value of the CRC register) is appended to the message starting from the lower byte

Example of appending the calculated result

If the calculated CRC value is H'1234, it is appended to the command frame as below.

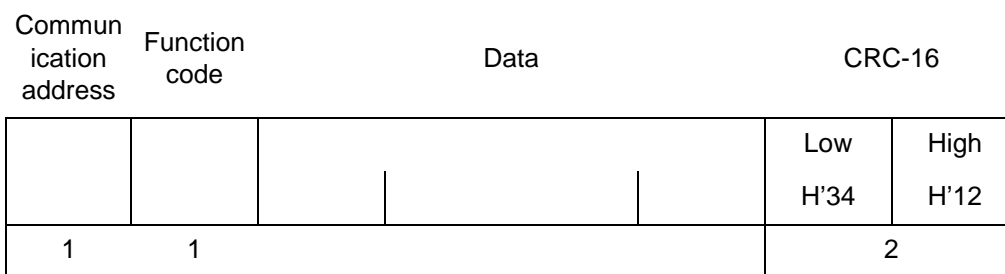

Range of CRC-16 calculation

6.2 Modbus (continued)

● List of function codes (FC)

Function code	Name	Description
03(H'03)	Variable area reading	Variable area is read successively.
16(H'10)	Variable area writing	Variable area is written successively.
06(H'06)	Command	Operations are performed according to commands.
08(H'08)	Echo back test	Echo back test is performed.

● List of error codes

Error code	Name	Description	Error detection Priority
H'01	Function code error	Using an unsupported function code.	1
H'02	Variable address error	Invalid value specified for variable address.	2
H'03	Variable data error	Data is invalid. <ul style="list-style-type: none"> • Mismatch with the number of elements • Data outside of range 	3
H'04	Operation error	The mode is not appropriate.	4
H'05	Status error (error is occurring)	A malfunction has occurred and the unit continues to be unusable.	5

6.2 Modbus (continued)

● Service details

■ Variable area read (03: H'03)

This service allows you to read all variable areas.

Reading of the variable areas is conducted by setting the required data in the following command frame. To read setting values "Parameter area list (⇒ 98)", you need to first move to the setting mode with a command. To read measurement values "List of variable areas (measurement values) (⇒ 96)", you can be in either the measuring mode or the setting mode. Also, measuring continues even while in the setting mode.

Command frame

Commu- nication address	Function code	Start reading address	Number of elements	CRC-16
1	H'03	2	2	2

- **Start reading address**

Specify the address for the measurement value or setting data you want to read. Refer to "6.4 Address map (⇒ 96)" for the address.

- **Number of elements**

Specify the number of pieces of data that you want to read times 2 as the number of elements. Only the consecutive addresses can be read in a batch.
Range: H'0002 to 0032 (2 to 50).

- **CRC-16**

This is a check code calculated from the communication address until the end of the data. Refer to "An example for CRC-16 calculation" for the calculation. (⇒ 74)

6.2 Modbus (continued)

Response frame

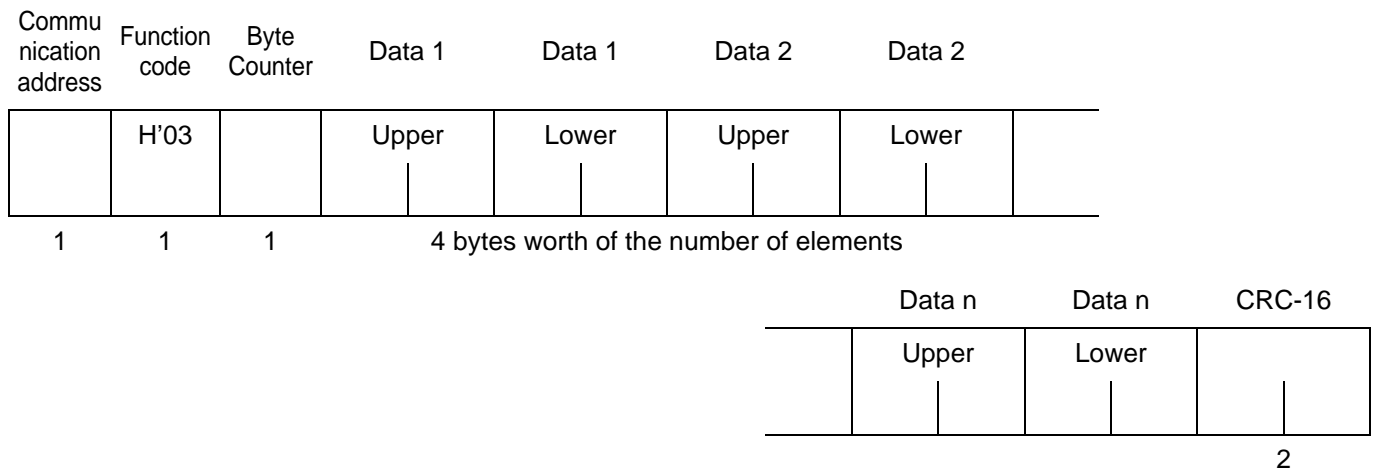

- **Byte counter**
The number of bytes of the read data is put here.
- **Data 1 to n**
The value of the read data is put here.
- **CRC-16**
This is a check code calculated from the communication address until the end of the data.
Refer to "An example for CRC-16 calculation" for the calculation. (⇒ 74)

Command/Response example

The following is an example of reading voltage 1.
(Communication address: When H'01)

Command

Commu nication address	Function code	Start reading address	Number of elements	CRC-16
01	03	0000	0002	C40B

Response

Commu nication address	Function code	Byte Coun ter	Data 1	Data 1	CRC-16
01	03	04	0000	0960	FC4B

6.2 Modbus (continued)

■ Variable area writing (16: H'10)

Writing to the variable areas is conducted by setting the required data in the following command frame. The parameter area can be written to. Before writing, you need to first move to the setting mode with a command. The content written is reflected by moving to the measuring mode in response to an instruction after writing of the parameters. Measuring continues even while in the setting mode.

Command frame

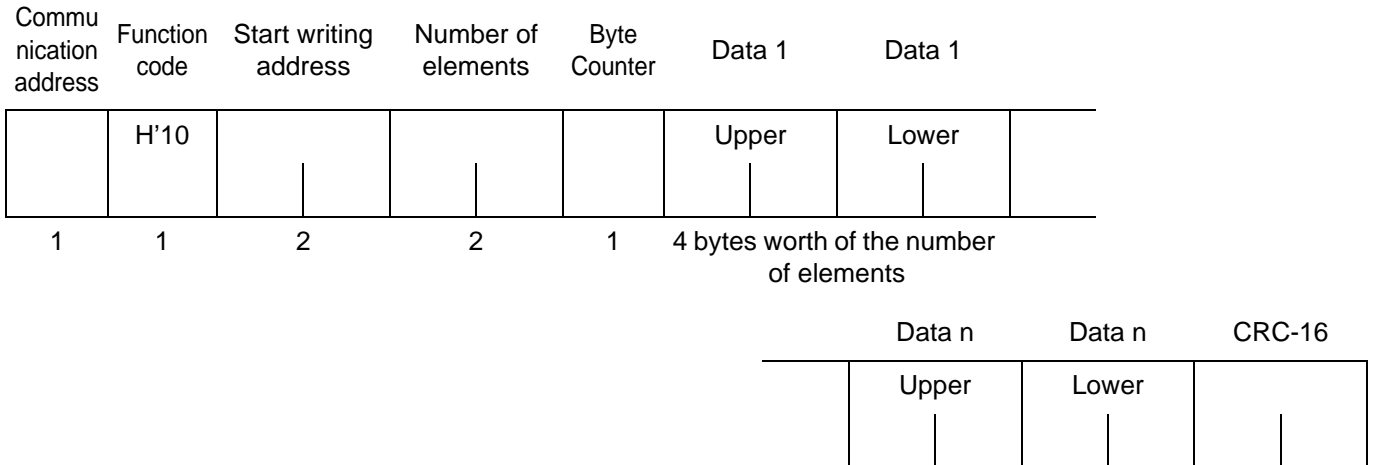

- Start writing address**
 Specify the address for setting data you want to write. Refer to "6.4 Address map (⇒ 96)" for the address.
- Number of elements**
 Specify the number of pieces of data that you want to write times 2 as the number of elements.
 Range: H'0002 to 0032 (2 to 50).
- Byte counter**
 Specify the number of bytes for written data.
- CRC-16**
 This is a check code calculated from the communication address until the data immediately preceding.
 Refer to "An example for CRC-16 calculation" for the calculation. (⇒ 74)

6.2 Modbus (continued)

Response frame

Commu- nication address	Function code	Start writing address	Number of elements	CRC-16
	H'10			
1	1	2	2	2

- **Start writing address**

The start writing address that was received.

- **Number of elements**

The number of elements that were received.

- **CRC-16**

This is a check code calculated from the communication address until the data immediately preceding. Refer to "An example for CRC-16 calculation" for the calculation. (⇒ 74)

Command/Response example

The following shows an example of writing when changing the phase and wire type to 1-phase 2-wire.

(Communication address: When H'01)

Address: H'2000 Written data: H'00000000

Command

Commu- nication address	Function code	Start writing address	Number of elements	Byte Counter	Data 1	Data 1	CRC-16
01	10	2000	0002	04	0000	0000	6A6E

Response

Commu- nication address	Function code	Byte Counter	Number of elements	CRC-16
01	10	04	0002	DD00

6.2 Modbus (continued)

■ Command (06: H'06)

Command frame

Communication address	Function code	Start writing address	Written data	CRC-16
	H'06	H'FF Fixed	H'FF Fixed	
1	1	2	2	2

Response frame

Communication address	Function code	Start writing address	Written data	CRC-16
	H'06	H'FF Fixed	H'FF Fixed	
1	1	2	2	2

- **Start writing address**

Set "FFFF" as the dedicated address for commands.

- **Written data**

The written data is 4 places consisting of the command code plus the related information. Commands are as follows. Specify command codes using hexadecimal numbers.

Instruction code	Related information	Instruction details
03(H'03)	00	Resets any active energy values that can be reset (individual units)
04(H'04)	00	Move to measuring mode
07(H'07)	00	Moving to setting mode
09(H'09)	00	Initialize (any active energy values that can be reset and setting values)
99(H'99)	00	Restart

6.2 Modbus (continued)

Command/Response example

The following is an example of an instruction for clearing the active energy.

(Communication address: When H'01)

Command code: "03" Related information: "00"

Command

Communication address	Function code	Start writing address	Written data	CRC-16
01	06	FFFF	0300	891E

Response

Communication address	Function code	Start writing address	Written data	CRC-16
01	06	FFFF	0300	891E

■ Echo back test (08: H'08)

Command frame

Communication address	Function code	Start writing address	Test data	CRC-16
	H'08	H'00 Fixed Fixed		
1	1	2	2	2

Response frame

Communication address	Function code	Start writing address	Test data	CRC-16
	H'08	H'00 Fixed Fixed		
1	1	2	2	2

- **Start writing address**

Set "0000" as the address for the echo back test.

- **Test data**

This is any data in 2-byte HEX format.

6.3 CompoWay/F

● Data format

In the following explanations, values preceded by H' (as in H'02) indicate hexadecimal values. Only items expressed as normal numerals or characters indicate ASCII characters.

The numbers under the frame sections are the number of bytes.

■ Command frame

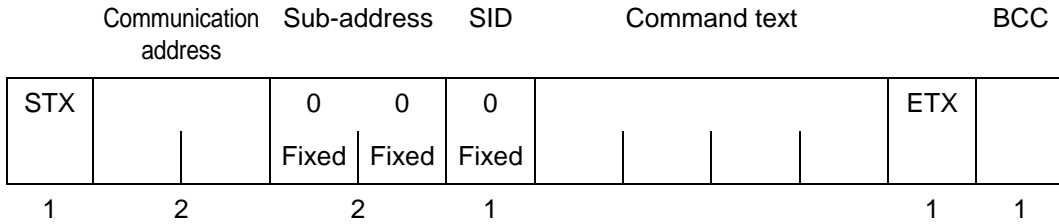

STX	This is the start code for the communication frame (H'02). • Make sure you set this code as the first byte.
Communication address	Specify the "communications address" of this product. • You can set a number between 00 and 99 or XX (upper case). • Specify "XX" to communicate to all at the same time. There will be no response if this is specified however. • Specify the communications address between 00 and 99 (BCD). There will be no response to any other communications address.
Sub-address	Not used for this product. Specify "00".
SID	Not used for this product. Specify "0".
Command text	This part describes the command.
ETX	Code to indicate the end of text. • Make sure you set the H'03 code as the end byte.
BCC	The block check character. • The BCC shall be the value gained from an exclusive OR (XOR) function conducted on each byte from the communications address to ETX.

■ Example of BCC calculation

The block check character (BCC) is calculated using an exclusive OR function on each byte of the values between the communications address and ETX, then that 8-bit data is set in the BCC section.

	Communication address		Sub-address		SID	Command text				ETX	BCC
02H	0(30H)	0(30H)	0(30H)	0(30H)	0(30H)	0(30H)	5(35H)	0(30H)	3(33H)	03H	35H
	BCC calculation range										

$$BCC = 30H \oplus 30H \oplus 30H \oplus 30H \oplus 30H \oplus 30H \oplus 35H \oplus 30H \oplus 33H \oplus 03H = 35H$$

The calculation result 35H is set in the BCC section.

6.3 CompoWay/F (continued)

■ Response frame

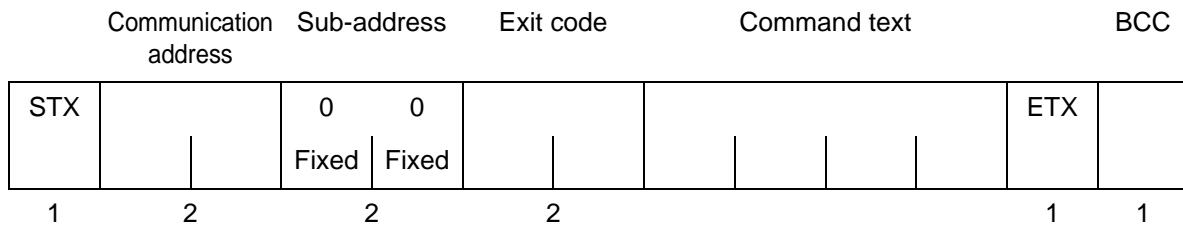

Exit code	Name	Description	Error detection Priority
00	Normal end	This indicates that the command ended normally and that there was no error.	None
0F	FINS command error	The specified FINS command could not be executed. Determine the reason for non-execution from the FINS response code.	3
14	Format error	<ul style="list-style-type: none"> The numbers 0 to 9 and letters A to F are used in command text (except in echo back tests). There is no SID or command text. Alternatively, there is no command text. MRC/SRC in the command text is incomplete. 	2
16	Sub-address error	<ul style="list-style-type: none"> The sub-address is invalid. 	1

- The exit code is returned as the reply when 1 command frame is received when sent to this unit.
- There is no response if the command is not complete between ETX and BCC.
- The error detection priority is the order when more than one error occurs.

■ Example exit codes

The following is an example of exit codes when the command did not end normally.
For example: When there is no command text

Command

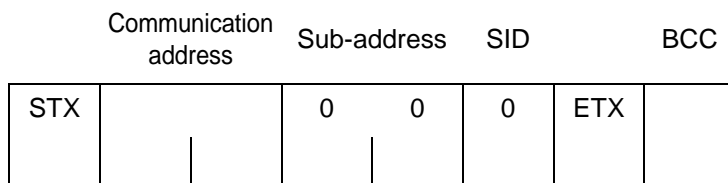

Response

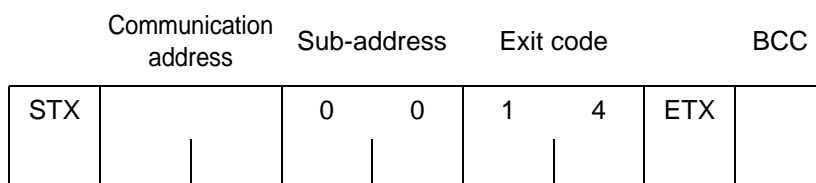

The exit code will be "14" (format error).

6.3 CompoWay/F (continued)

For example: The sub-address is less than 2 characters and there is no SID or FINS-mini

Command

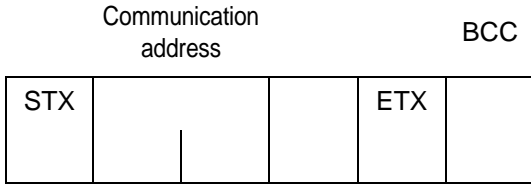

The sub-address lacks a character

Response

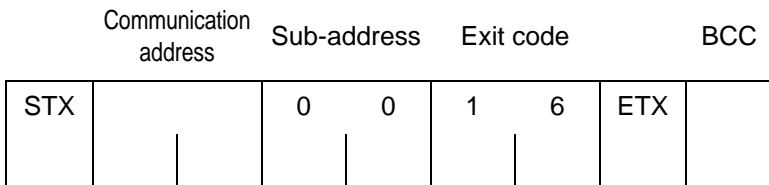

The sub-address is "00" and the exit code is "16" (a sub-address error).

- The composition of the Protocol Data Unit (PDU)**

Command text (or PDU) consists of the main request code (MRC), the sub-request code (SRC), and the data required by these, and these are transferred.

Service request PDU



Continuing on from the above MRC and SRC, main response codes (MRES) and sub-response codes (SRES) are transferred to the response frame, and then the data is transferred.

Service response PDU (normal)

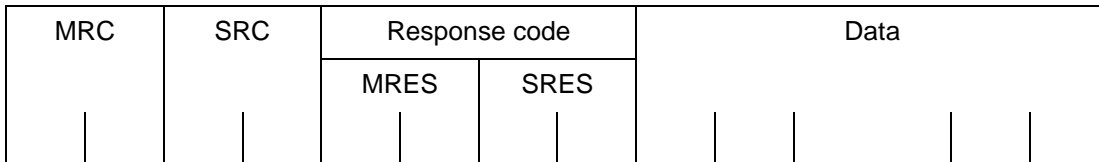

If the specified command text could not be executed, then the service response PDU will consist of only the MRC/SRC and response code.

6.3 CompoWay/F (continued)

● Type code

The type codes used with this product are as follows.

■ Variable area

Variable type code	Description
C0	The measured values

■ Parameter area

Variable type code	Description
C000	The parameter values for various settings

● List of services

MRC	SRC	Service name	Processing
01	01	Read variable area	Variable area is read.
02	01	Read parameter area	Parameter area is read.
02	02	Write parameter area	The parameter area is written.
05	03	Read unit properties	The model and the communication buffer size are read.
06	01	Read controller status	Operating status is read.
08	01	Echo back test	Echo back test is performed.
30	05	Command	Operations are performed according to commands.

6.3 CompoWay/F (continued)

● List of response codes

When normal end

code	Name	Description	Priority
0000	Normal end	No error.	None

When an error occurs

code	Name	Description	Priority
0401	Unsupported command	This is an unsupported service function.	1
1001	Over command length	The command length is too long.	2
1002	Insufficient command length	The command is not long enough.	3
1003	Mismatched element and data numbers	There is a mismatch between the number of elements and the number of pieces of data.	6
1100	Parameter error	The parameter value is unsupported.	8
1101	Area type error	An unsupported area type has been specified.	4
1103	Start writing address out of range error	The value of the start writing address is out of range.	5
110B	Response length too long	The length exceeds the communications buffer.	7
2203	Operation error	Cannot process the command.	10
3000	Status error (error is occurring)	The unit is malfunctioning.	11
3003	Read only	Writing to the variable area.	9

6.3 CompoWay/F (continued)

● Service details

Addresses, numbers of elements, and data are shown in hexadecimal notation.

■ Variable area read (0101)

Variable area is read.

Service request PDU

MRC		SRC		Variable Type		Start reading address				Bit Position		Number of elements			
0	1	0	1	C	0					0	0				
2		2		2		4				2					

Service response PDU (normal)

MRC		SRC		Response code				Read data (For the number of elements)							
0	1	0	1												
2		2		4				8xn(n:0 to 25)							

- **Variable type and address to start reading**

Refer to "6.4 Address map" for the different variable types and the start reading address. (⇒ 96)

- **Bit position**

This product does not support bit access. Fixed at "00".

- **Number of elements**

Specifies the number of variables to read.

Number of elements	Processing
0000	Nothing is read and the end is normal. (Read data is not appended to the service response PDU)
0001 to 0019	A maximum of 25 (H'19) are read and the end is normal.

- When the start reading address is an address within the variable area and the end reading address (the start reading address plus the number of elements) exceeds the valid addresses of the variable area, then if the number of data up to the end of the end address is within the range specified by the number of elements, reading is done and the end is normal. In this case, the number of data read will be fewer than the number of elements specified in the command. Further, if the start reading address is outside of the variable area, there will be a start address out of range error.

- **Response code**

Refer to "List of response codes" for details about each response code. (⇒ 86)

6.3 CompoWay/F (continued)

Example of read variable area communications

This example shows how to read the two measurement values with one command when the measurement is of voltage 1 at 103.7V and voltage 2 at 103.6V

Command

"(H'02)	<u>00</u>	<u>00</u>	<u>0</u>	<u>01</u>	<u>01</u>	<u>C0</u>	<u>0000</u>	<u>00</u>	<u>0002</u>	<u>(H'03)</u>	<u>(H'42)</u> "
STX	Commu- nication address	Sub- address	SID	MRC	SRC	Variable Type	Start reading address	Bit Position	Number of elements	ETX	BCC

Response

"(H'02)	<u>00</u>	<u>00</u>	<u>00</u>	<u>01</u>	<u>01</u>	<u>0000</u>	<u>0000040D</u>	<u>0000040C</u>	<u>(H'03)</u>	<u>(H'02)</u> "
STX	Commu- nication address	Sub- address	Exit code	MRC	SRC	Respon- se code	Voltage 1	Voltage 2	ETX	BCC

This product converts measured values to hexadecimal without decimal points for response. H'0000040D would be 1037 (in decimal).

6.3 CompoWay/F (continued)

■ Read parameter area (0201)

Parameter area is read.

Service request PDU

MRC	SRC	Parameter type	Start reading address	Number of elements
0 2	0 1	C 0 0 0		
2	2	4	4	4

Service response PDU (normal)

MRC	SRC	Response code	Parameter Type	Start reading address	Number of elements	Read data (For the number of elements)
0 2	0 1					
2	2	4	4	4	4	8xn (n: 0 to 25)

- **Variable type and address to start reading**
Refer to "Address map" for the variable types and the start reading address. (⇒ 96)
- **Number of elements**
Specifies the number of variables to read.

Number of elements	Processing
8000	Nothing is read and the end is normal. (Read data is not appended to the service response PDU)
8001 to 8019	A maximum of 25 (H'19) are read and the end is normal. • The uppermost but must always be set to 1.

- When the start reading address is an address within the variable area and the end reading address (the start reading address plus the number of elements) exceeds the valid addresses of the variable area, then if the number of data up to the end of the end address is within the range specified by the number of elements, reading is done and the end is normal. In this case, the number of data read will be fewer than the number of elements specified in the command. Further, if the start reading address is outside of the variable area, there will be a start address out of range error.
- **Response code**
Refer to "List of response codes" for details about each response code. (⇒ 86)

6.3 CompoWay/F (continued)

Example of read parameter area communications

This example shows how to read two settings with one command where the phase and wire type is set to 1-phase 2-wire and the communications address is 10

Command

"(H'02)	<u>10</u>	<u>00</u>	<u>0</u>	<u>02</u>	<u>01</u>	<u>C000</u>	<u>1000</u>	<u>8002</u>	<u>(H'03)</u>	<u>(H'49)"</u>
STX	Communi- cation address	Sub- address	SID	MRC	SRC	Parameter Type	Start reading address	Number of element s	ETX	BCC

Response

"(H'02)	<u>10</u>	<u>00</u>	<u>00</u>	<u>02</u>	<u>01</u>	<u>0000</u>	<u>1000</u>	<u>8002</u>		
STX	Communi- cation address	Sub- address	Exit code	MRC	SRC	Parameter Type	Start reading address	Number of element s		
						<u>00000000</u>	<u>0000000A</u>		<u>(H'03)</u>	<u>(H'08)"</u>
						Phase and wire type	Communication address		ETX	BCC

- If the phase and wire type is 1-phase 2-wire, H'00000000 is read. The communications address will be H'0000000A=10 (decimal).

6.3 CompoWay/F (continued)

■ Write parameter area (0202)

Writing to the parameter area starts.

This service is made valid by using a command to move to the settings mode. The content written is reflected by moving to the measuring mode in response to an instruction after writing of the parameters.

Service request PDU

MRC	SRC	Parameter type	Start writing address	Number of elements	Written data (For the number of elements)
0 2	0 2	C 0 0 0			
2	2	4	4	4	8xn(n:0 to 25)

Service response PDU (normal)

MRC	SRC	Response code
0 2	0 2	
2	2	4

- **Variable type and address to start writing**

Refer to "Address map" for the different variable types and the start writing address.(⇒ 96)

- **Number of elements**

Specifies the number of variables to be written.

Number of elements	Processing
8000	Nothing is written and the end is normal. (Written data is not appended to the service response PDU)
8001 to 8019	A maximum of 25 (H'19) are written and the end is normal. <ul style="list-style-type: none"> • The uppermost bit must always be set to 1.

- When the start writing address is an address within the variable area and the end writing address (the start writing address plus the number of elements) exceeds the valid addresses of the variable area, then if the number of data up to the end of the end address is within the range specified by the number of elements, writing is done and the end is normal. In this case, the number of data written will be fewer than the number of elements specified in the command. Further, if the start writing address is outside of the variable area, there will be a start address out of range error.
- Response code
Refer to "List of response codes" for details about each response code. (⇒ 86)

6.3 CompoWay/F (continued)

Example of write parameter communications

Example of a command to set the CT secondary side to 1A

Command

"(H'02)	00	00	0	02	02	C000	100A	8001	00000000	(H'03)	(H'48)"
STX	Communica- tion address	Sub- address	SID	MRC	SRC	Parameter Type	Start writing address	Number of element s	Written data CT used:1A	ETX	BCC

Response

"(H'02)	00	00	00	02	02	0000	(H'03)	(H'03)"
STX	Communica- tion address	Sub- address	Exit code	MRC	SRC	Response code	ETX	BCC

The address for the CT secondary side is 100A, and setting the used CT to 1A is H'00000000.

■ Read unit properties (0503)

The model and buffer size are read.

Service request PDU

MRC	SRC
0 5	0 3
2	2

Service response PDU

MRC	SRC	Response code	Model	Buffer size
0 5	0 3			0 0 E 6
2	2	4	10	4

- **Model**

The model is displayed in 10 bytes of ASCII code. Space codes are used if the model doesn't take up 10 bytes. For example: This will be as follows for model KM-N3-FLK

K	M	-	N	3	-	F	L	K	
---	---	---	---	---	---	---	---	---	--

- **Buffer size**

The buffer size 230 is read as "00E6" (fixed value).

- **Response code**

Refer to "List of response codes" for details about each response code. (⇒ 86)

6.3 CompoWay/F (continued)

■ Controller status read (0601)

Reads operational state and error status.

Service request PDU

MRC	SRC
0 6	0 1
2	2

Service response PDU (normal)

MRC	SRC	Response code	Operational state	Related information
0 6	0 1			
2	2	4	2	2

• Operational state

Operational state	Description
00	The unit is measuring without error.
01	An error has occurred and measuring has stopped.

• Related information

Bit position	Meaning	Description
B0(LSB)	Memory error	0: no error, 1: error
B1	VR open phase warning	0: No warning, 1: Warning
B2	VS open phase warning	0: No warning, 1: Warning
B3	VT open phase warning	0: No warning, 1: Warning
B4	Input frequency warning	0: No warning, 1: Warning
B5	Phase sequence error	0: No warning, 1: Warning
B6	Active power is a negative value	0: No warning, 1: Warning
B7(MSB)	Pulse output warning	0: No warning, 1: Warning

- If there is one pulse output warning from amongst OUT1 to 4, the B7 will be 1.

• Response code

Refer to "List of response codes" for details about each response code. (⇒ 86)

Example of bit information for related information

If a memory error (B0) occurs, the bits in the related information of the status information appear as follows. Displayed as "01" in the PDU.

B7	B6	B5	B4	B3	B2	B1	B0
0	0	0	0	0	0	0	1

6.3 CompoWay/F (continued)

■ Echo back test (0801)

Echo back test is performed.

Service request PDU

MRC		SRC		Test data															
0	8	0	1																
2		2		0 to 200															

Service response PDU (normal)

MRC		SRC		Response code				Test data											
0	8	0	1																
2		2		4				0 to 200											

- **Test data**

Set any test data within the range 0 to 200.

- **Response code**

Refer to "List of response codes" for details about each response code. (⇒ 86)

6.3 CompoWay/F (continued)

■ Command (3005)

Used when remotely controlling the unit.

Service request PDU

MRC		SRC		Instruction code	Related information
3	0	0	5		
2		2		2	2

Service response PDU (normal)

MRC		SRC		Response code	
3	0	0	5		
2		2		4	

- **List of command codes and related information**

Related information is fixed at 00.

Instruction code	Related information	Instruction details
03	00	Resets any active energy values that can be reset (individual units)
04	00	Move to measuring mode
07	00	Moving to setting mode
09	00	Initialize (any active energy values that can be reset and setting values)
99	00	Restart

- **Response code**

Refer to "List of response codes" for details about each response code. (⇒ 86)

6.4 Address map

● List of variable areas (measurement values)

Used when remotely controlling the unit.

address		Type	Item		R/W
CompoWay/F	Modbus RTU		Parameter name	Monitor value	
0000	0000	Measured value (momentary)	Voltage V1 (V)	H'00000000 to H'0098967F (0 to 9999999) 10 times the voltage	R
0001	0002		Voltage V2 (V)		R
0002	0004		Voltage V3 (V)		R
0003	0006		Current I1 (A)	H'00000000 to H'05F5E0FF (0 to 99999999) 1000 times the current	R
0004	0008		Current I2 (A)		R
0005	000A		Current I3 (A)		R
0006	000C		Power factor	H'FFFFFF9C to H'00000064 (-100 to 100) 100 times the power factor	R
0007	000E		Frequency (Hz)	H'000001C2 to H'0000028A (450 to 650) 10 times the frequency	R
0008	0010		Effective power (total) (W)	H'80000000 to H'7FFFFFFF (-2147483648 to 2147483647) 10 times the active and reactive power	R
0009	0012		Reactive power (total) (W)		R
000A	0014		Voltage V1-V2 (V)	H'00000000 to H'0098967F (0 to 9999999) 10 times the voltage	R
000B	0016		Voltage V1-V3 (V)		R
000C	0018		Voltage V2-V3 (V)		R
000D	001A		Effective power 1 (W)	H'80000000 to H'7FFFFFFF (-2147483648 to 2147483647) 10 times the active and reactive power	R
000E	001C		Effective power 2 (W)		R
000F	001E		Effective power 3 (W)		R
0010	0020		Reactive power 1 (Var)		R
0011	0022		Reactive power 2 (Var)		R
0012	0024		Reactive power 3 (Var)		R
0100	0200		Integrate effective energy (Wh)		H'00000000 to H'3B9AC9FF (0 to 99999999) Value that is 1 times each value
0101	0202	Integrate regenerative energy (Wh)	R		
0102	0204	Integrated reactive energy of advance (Varh)	R		
0103	0206	Integrated reactive energy of delay (Varh)	R		
0104	0208	Integrated total reactive energy (Varh)	R		
0105	020A	Integrated T1 effective energy (Wh)	R		
0106	020C	Integrated T2 effective energy (Wh)	R		
0107	020E	Integrated T3 effective energy (Wh)	R		
0108	0210	Integrated T4 effective energy (Wh)	R		
0110	0220	Integrate effective energy (kWh)	H'00000000 to H'3B9AC9FF (0 to 99999999) Value that is 1 times each value	R	
0111	0222	Integrate regenerative energy (kWh)		R	
0112	0224	Integrated reactive energy of advance (kVarh)		R	
0113	0226	Integrated reactive energy of delay (kVarh)		R	
0114	0228	Integrated total reactive energy (kVarh)		R	
0115	022A	Integrated T1 effective energy (kWh)		R	
0116	022C	Integrated T2 effective energy (kWh)		R	
0117	022E	Integrated T3 effective energy (kWh)		R	
0118	0230	Integrated T4 effective energy (kWh)	R		

6.4 Address map (continued)

address		Type	Item		R/W
CompoWay/F	Modbus RTU		Parameter name	Monitor value	
0120	0240	Measured value (integration) Able to reset	Integrate effective energy (Wh)	H'00000000 to H'3B9AC9FF (0 to 999999999) Value that is 1 times each value	R
0121	0242		Integrate regenerative energy (Wh)		R
0122	0244		Integrated reactive energy of advance (Varh)		R
0123	0246		Integrated reactive energy of delay (Varh)		R
0124	0248		Integrated total reactive energy (Varh)		R
0125	024A		Integrated T1 effective energy (Wh)		R
0126	024C		Integrated T2 effective energy (Wh)		R
0127	024E		Integrated T3 effective energy (Wh)		R
0128	0250		Integrated T4 effective energy (Wh)		R
0130	0260		Measured value (integration 2) Able to reset		Integrate effective energy (kWh)
0131	0262	Integrate regenerative energy (kWh)		R	
0132	0264	Integrated reactive energy of advance (kVarh)		R	
0133	0266	Integrated reactive energy of delay (kVarh)		R	
0134	0268	Integrated total reactive energy (kVarh)		R	
0135	026A	Integrated T1 effective energy (kWh)		R	
0136	026C	Integrated T2 effective energy (kWh)		R	
0137	026E	Integrated T3 effective energy (kWh)		R	
0138	0270	Integrated T4 effective energy (kWh)		R	
0180	0300	Converted value	Converted value (x1000 value of calculated value)	H'00000000 to H'3B9AC9FF (0 to 999999999) Value that is 1 times each value	R
0181	0302		Converted value (x0.001 value of calculated value)		R

- Only the consecutive address items can be read in a batch.
- The relationship between phase and wire type and the data is shown in the table below.

CompoWay/F	Modbus RTU	Parameter name	1P2W	1P3W	3P3W	3P4W
0000	0000	Voltage V1 (V)	Vrn	Vrn	—	Vrn
0001	0002	Voltage V2 (V)	—	—	—	Vsn
0002	0004	Voltage V3 (V)	—	Vtn	—	Vtn
0003	0006	Current I1 (A)	IR	IR	IR	IR
0004	0008	Current I2 (A)	—	IN*	IS*	IS
0005	000A	Current I3 (A)	—	IT	IT	IT
000A	0014	Voltage V1-V2 (V)	—	—	Vrs	Vrs
000B	0016	Voltage V1-V3 (V)	—	Vrt	Vrt	Vrt
000C	0018	Voltage V2-V3 (V)	—	—	Vst	Vst
000D	001A	Effective power 1 (W)	—	Pr	—	Pr
000E	001C	Effective power 2 (W)	—	—	—	Ps
000F	001E	Effective power 3 (W)	—	Pt	—	Pt
0010	0020	Reactive power 1 (Var)	—	Qr	—	Qr
0011	0022	Reactive power 2 (Var)	—	—	—	Qs
0012	0024	Reactive power 3 (Var)	—	Qt	—	Qt

* Current is the measured value calculated from current I1 and current I3.

6.4 Address map (continued)

● Parameter area list

Address		Type	Item	R/W
CompoWay/F	Modbus RTU			
1000	2000	Unit Individual setting	Phase and wire type H'00000000 : 1P2W H'00000001 : 1P3W H'00000002 : 3P3W H'00000003 : 1P2W2 H'00000004 : 1P3W2 H'00000005 : 3P4W	R/W
1001	2002		Communication address 00 to 99 : CompoWay/F 01 to 99 : Modbus RTU	R
1008	2010		Pulse output ON/OFF 0 : OFF 1 : ON	R/W
1009	2012		Voltage selected 0 : V_R 1 : V_T 2 : V_R-T	R/W
100A	2014		CT secondary side current H'00000000 : 1A H'00000001 : 5A	R/W
100B	2016		CT primary side current x1 value of amperage 1 to 9999	R/W
1100	2200		Common settings	Protocol 0 : CompoWay/F 1 : Modbus
1101	2202	Communication speed 0 : 1200bps 1 : 2400bps 2 : 4800bps 3 : 9600bps 4 : 19200bps 5 : 38400bps		R/W
1102	2204	Data length 0 : 7bit 1 : 8bit		R/W
1103	2206	Stop bit 0 : 1bit 1 : 2bit		R/W
1104	2208	Parity 0 : NONE 1 : ODD 2 : EVEN		R/W
1105	220A	Transmission wait time Unit: ms 0 to 99		R/W
1106	220C	Pulse output units 0 : 1Wh 1 : 10Wh 2 : 100Wh 3 : 1kWh 4 : 5kWh 5 : 10kWh 6 : 50kWh 7 : 100kWh		R/W

6.4 Address map (continued)

address		Type	Item	R/W
CompoWay/F	Modbus RTU			
1107	220E	Common settings	VT-ratio setup VT ratio x 100 100 to 99999	R/W
1108	2210		Conversion factor Factor x 100 0 to 99999	R/W
110A	2214		LCD OFF waiting time 0 : OFF 1 : 1 minute 2 : 5 minutes 3 : 10 minutes	R/W
110C	2218		Alarm ON/OFF 0 : OFF 1 : ON	R/W
110D	221A		Tariff ON/OFF 0 : OFF 1 : ON	R/W
110E	221C		Current tariff 0 : T1 1 : T2 2 : T3 3 : T4	R/W
1200	2400		Model 1 (KM-N)	R
1201	2402		Model 2 (3-FL)	R
1202	2404		Model 3 (K (sp)(sp)(sp))	R
1203	2406		Software version (Ex.: 100)	R
1204	2408		Status information	R
1205	240A		Buffer size (230 fixed)	R

7.1 Warnings

Warnings come as errors and alarms. The types of errors and alarms are described below.

Warning type		Description	Display	Action to take
Error	Setting value error	Internal memory corrupted	E-M1	Contact the place of purchase or the manufacturer.
	Measured value error	Internal memory corrupted	E-M2	
	Calibration value error	Calibration value is corrupted	E-M3	
Alarm	Input frequency warning	Measured frequency is outside rated ranges	A-F1	Input the power and voltage with the frequency within the rated ranges.
	VR phase warning	The voltage has not reached the rated value	A-VR	Wire correctly.
	VS phase warning		A-VS	
	VT phase warning		A-VT	
	Phase sequence error	The phase sequence is incorrect for 1-phase 3-wire, 3-phase 3-wire, or 3-phase 4-wire connection	A-W2	Wire correctly.
	Active power is a negative value	Active power is a negative value (The voltage and current phase may not match due to incorrect wiring)	A-W3	Check the wiring, and correct it if there is anything inappropriate. *
	OUT1 Output warning	<ul style="list-style-type: none"> Pulse is output again while a pulse is being output Pulse is output during a period when the pulse is off 	A-P1	Change the pulse output unit so that pulses are not output while other pulses are being output.
	OUT2 Output warning		A-P2	
	OUT3 Output warning		A-P3	
OUT4 Output warning	A-P4			

* If you intend to meter negative values (exported energy), then no correction is necessary. Metering continues normally even when a warning is displayed. If the warning is not needed, go to "Warning for negative reactive power value ON/OFF (MENU 0A)" and set to OFF (⇒ 65).

*To cancel the alarm, take the actions described to remove the cause, then restart the product or switch the power on again.

7.2 Troubleshooting

Check if an issue is covered by the following items if the product doesn't seem to be working correctly.

Phenomena	Description	Action to take	Page
The main unit doesn't start	Is the LCD display off?	The unit isn't being supplied with power. Check that the voltage terminals have been wired and that voltage within the rated range is being supplied.	⇒ 28
		The power saving mode is working. The LCD will light again when you press any of the switches.	⇒ 64
Cannot measure voltage	Are the voltage connections and phase correct?	Check that the voltage connection matches the phase and wire type you have selected.	⇒ 38
	Have you selected 1P2W2 (1-phase 2-wire voltage selected) or 1P3W2 (1-phase 3-wire composite) as the phase and wire type?	If you have selected 1P2W2 or 1P3W2 as the phase and wire type, set the correct voltage allocation for the branching 1-phase 2-wire.	⇒ 61
Cannot measure current	Is the CT connected?	Connect the CT to the main unit. Also check if the CT has become separated from the electric wire.	⇒ 26
	Is the connection positioning of the measuring circuits and the CT terminals correct?	Circuit A uses CTs 1, 2, or 3, circuit B uses CT 2, circuit C uses CT 3 or 4, and circuit D uses CT 4. Connect properly according to the connection diagrams.	⇒ 26
Voltage and current can be measured, but power cannot be measured	Are the CT fitted back to front?	If negative electricity is being measured, there is a chance that all of the fitted CTs have been fitted back to front. Alternatively, if electricity is being measured is a value near 0, there is a chance that one of the fitted CTs has been fitted back to front.	⇒ 31
	Is the voltage phase correct?	Power cannot be correctly measured if the phase of the voltage is not correct. If the function for warning about miss-wiring is on, "A-VR", "A-VS", "A-VT" and "A-W2" are displayed. Wire correctly.	⇒ 38, 65
	Have you selected 1P2W2 (1-phase 2-wire voltage selected) or 1P3W2 (1-phase 3-wire composite) as the phase and wire type?	If you have selected 1P2W2 or 1P3W2 as the phase and wire type, set the correct voltage allocation for the branching 1-phase 2-wire.	⇒ 61

7.2 Troubleshooting (continued)

Phenomena	Description	Action to take	Page
There is a large discrepancy in measured values	Does the selected phase and wire type match the wiring?	Wire correctly.	⇒ 38
	Does the CT match the secondary current and primary current settings of the CT?	Check the secondary current and primary current of the CT you are using and set the right values.	⇒ 13
		If you are using multi-circuit metering, the secondary current and primary current of all of the circuits you are using need to be set.	⇒ 55
		With multi-circuit metering, CT1 corresponds to circuit A, CT2 corresponds to circuits A and B, CT3 corresponds to circuits A and C, and CT4 corresponds to circuits C and D.	⇒ 55
	Has the input exceeded the input range of the CT?	Check the secondary current and primary current of the CTs you are using and use CTs that have appropriate rated current values for the circuit being measured.	⇒ 13
	Is the phase and wire type setting correct?	Check the phase and wire type for the measuring circuits and make the correct settings.	⇒ 52
Pulse is not output	Is the pulse output wiring correct?	Wire correctly.	⇒ 32
	Is the pulse output set?	You need to set which of the OUT1/OUT2/OUT3/OUT4 pulse output terminals to output from. The default is for all of them to be OFF (no pulse output). Make sure they have been set.	⇒ 60
	Is the pulse output unit too large for the active energy?	If the pulse output units are too large for the increases in active energy, the interval between pulse outputs will be wide. Reduce the pulse output units.	⇒ 60

7.2 Troubleshooting (continued)

Phenomena	Description	Action to take	Page
RS-485 communications not possible	Is the wiring correct?	Wire correctly.	⇒ 36
	Are the communications settings correct?	Check that the communications settings between this product and the host system match.	⇒ 57
	Have you connected fewer units than the maximum number of units you can connect on the same line?	The maximum number of units you can connect when the protocol is Modbus is 99 units, and when the protocol is CompoWay/F the maximum is 31. (The parent device is not included in either of these numbers.)	⇒ 36
	Have you set separate communications addresses for each circuit?	Make sure the communications addresses do not duplicate across circuits when using multi-circuit metering. Also, if you connect several of these products, allocate all of the circuits different communications addresses.	⇒ 55
I have forgotten the password and cannot get into the setting mode	—	Contact the place of purchase or the manufacturer.	—

8.1 Specifications

■ Main unit specifications

Item	Content
Rated input voltage	AC100 to 240V
Rated frequency	50/60Hz
Variation range of power supply voltage	85 to 110% of rated power supply voltage
Variation range of power supply frequency	45 to 65Hz
Power consumption	7VA or less
Ambient operating temperature	-25 to 55 °C (with no icing or condensation)
Ambient operating humidity	25 to 85%RH
Storage temperature	-25 to 85 °C (with no icing or condensation)
Storage humidity	25 to 85%RH
Dielectric strength voltage	1) Between the set of electric circuits and the case: 1400 VAC for 1 minute 2) Between the batch input of power supply, voltage, and current and the set of communication terminals and pulse output terminals: 1400 VAC for 1 minute
Insulation resistance	1) Between electronic circuitry and case: 20MΩ max. (at DC500V mega) 2) Between the batch input of power supply, voltage, and current and the set of communication terminals and pulse output terminals: 20MΩ max. (at 500 VDC mega)
Vibration resistance	Single amplitude: 0.1mm, Acceleration: 15m/s ² , Frequency: 10 to 150Hz 10 sweeps for eight minutes along the three axes
Shock resistance	150m/s ² , 3 times each in the up, down, left, right, forward, and back directions
Electromagnetic environment	Industrial electromagnetic environment (EN/IEC 61326-1 Table 2)
Display and Operation	LCD display, buttons
Weight	Approximately 300g (main unit), approximately 400g (when in packaging)
Mounting	Mounting on the panel
Altitude	Under 2000m
Installation environment	Overvoltage category and measurement category: II, Pollution level: 2
Applicable standards	EN61010-1, EN61010-2-030, EN61326-1, UL61010-1, UL61010-2-030
Supplied Accessories	Instruction Manual (this document), compliance sheet, Mounting adapter, waterproof packing

■ Measurement specifications

Item	Description
Active power	0.5%* (Compliant with IEC62053-22 Class 0.5S) **
Reactive power	2% *(Compliant with IEC62053-23 class 2) **
Measurement frequency	80ms (at 50Hz), 66.7ms (at 60Hz)
Functions	Simple measurement, conversion

* This does not include the measuring error margin of the generic CT.

** IEC62053 is an international standard dealing with electricity metering.

8.1 Specifications (continued)

■ Measurement input specifications

Item	Description
Applicable circuit type	3-phase 4-wire, 1-phase 2-wire, 1-phase 3-wire, 3-phase 3-wire
Number of measuring circuits	3-phase 4-wire :Maximum 1 circuit 1-phase 2-wire :Maximum 4 circuits 1-phase 3-wire, 3-phase 3-wire :Maximum 2 circuits
Rated input voltage	3-phase 4-wire (earthed neutral) : 100 to 277 VAC (L-N), 173 to 480 VAC (L-L) 3-phase 4-wire (unearthed neutral) : 100 to 120 VAC (L-N), 173 to 208 VAC (L-L) 1-phase 2-wire : 100 to 277 VAC 1-phase 3-wire : 100 to 240 VAC (L-N), 200 to 480 VAC (L-L) 3-phase 3-wire : 173 to 277 VAC (L-L)
Variation range of input voltage	85 to 110% of rated input voltage
Connectable CTs	Generic CT (Secondary rated current: 1A or 5A)*
Rated current for CT secondary side	1A
Maximum current for CT secondary side	6A

* Use a CT with a rated load of 1.0 VA or more.

● Regarding the compliance with CT standards

○ : Available × : Not available	UL and CSA compliant	UL and CSA not compliant, CE compliant	Not compliant all of UL, CSA, and CE
KM-NCT-E□□□A	×	○	○
KM20-CTN□□□	×	×	○
KM-NCT-□□□A	×	×	×
KM20-CTF-□□□A	×	×	×
Listing CT of XOBA /XOBA 7category	○	Please check with the CT distributor.	○

■ Output specifications

Item	Description
Pulse output (Active energy)	Number of output points : 4 (PhotoMOS relay outputs) Output capacity : DC40V, 50mA or less Residual voltage when ON : Less than 1.5V (when output current is 50mA) Current leakage when OFF : 0.1mA maximum Output units : 1,10,100,1k,5k,10k,50k,100k (Wh) Pulse ON time : 500ms fixed
RS-485	Protocol : Modbus(RTU), CompoWay/F Sync method : Asynchronous Communication speed : 38400, 19200, 9600, 4800, 2400, 1200bps Maximum transmission distance : 1200m Maximum number of devices connected : 99 (Modbus), 31 (CompoWay/F)

8.1 Specifications (continued)

■ Option Products (Order Separately)

Product Name	Model	Description
Terminal covers	E53-COV24	Cover for screw terminal block (3 covers provided)
Waterproof packing	Y92S-P10	Waterproof packing
Mounting adaptors	Y92F-51	Adapter to fix the main unit to the panel (2 covers provided)

* The waterproof packing is provided with the KM-N3.

* The mounting adaptors are provided with the KM-N3.

■ Dedicated CT specifications

Model	KM-NCT-E100A	KM-NCT-E250A	KM-NCT-E500A
Rated primary current: I_n	100 A	250 A	500 A
Rated secondary current: I_s	1 A		
Rated frequency	50/60Hz		
Overcurrent withstand capability (continuous)	1.2 I_n		
Overcurrent withstand capability (1 sec)	4 I_n		
Output characteristics	±3% FS	±1% FS	
Phase error	±180 minutes (1.0 I_n) ±240 minutes (0.2 I_n)	±60 minutes (1.0 I_n) ±90 minutes (0.2 I_n)	
Rated load	1 VA		
Insulation resistance	100M Ω min. (at DC500V mega) between core and all output terminals		
Dielectric strength voltage	AC2300V, 1 minute between core and all output terminals		
Weight	Approx. 170g	Approx. 175g	Approx. 290g
Maximum wire diameter	24 dia.	24 dia.	36 dia.
Output overvoltage protection	Built-in clamp element		
Operating temperature and humidity range	-20 to 55°C, relative humidity: 85% max. with no condensation		
Storage temperature and humidity range	-30 to 90°C, relative humidity: 85% max. with no condensation		
Applicable standards *	EN61010-1, EN61010-2-030, EN61326-1		
Installation environment	Overvoltage category and measurement category: II, Pollution level: 2		

* Only applied when attached to the main unit.

* UL standards are not supported.

8.2 ASCII code table

Binary	Decimal	Hexadecimal	Character	Binary	Decimal	Hexadecimal	Character
0000000	0	0	NUM	0100000	32	20	SP
0000001	1	1	SHO	0100001	33	21	!
0000010	2	2	STX	0100010	34	22	"
0000011	3	3	ETX	0100011	35	23	#
0000100	4	4	EOT	0100100	36	24	\$
0000101	5	5	ENQ	0100101	37	25	%
0000110	6	6	ACK	0100110	38	26	&
0000111	7	7	BEL	0100111	39	27	'
0001000	8	8	BS	0101000	40	28	(
0001001	9	9	TAB	0101001	41	29)
0001010	10	A	LF	0101010	42	2A	*
0001011	11	B	VT	0101011	43	2B	i
0001100	12	C	FF	0101100	44	2C	,
0001101	13	D	CR	0101101	45	2D	-
0001110	14	E	SO	0101110	46	2E	.
0001111	15	F	SI	0101111	47	2F	/
0010000	16	10	DEL	0110000	48	30	0
0010001	17	11	DC1	0110001	49	31	1
0010010	18	12	DC2	0110010	50	32	2
0010011	19	13	DE3	0110011	51	33	3
0010100	20	14	DE4	0110100	52	34	4
0010101	21	15	NAK	0110101	53	35	5
0010110	22	16	SYN	0110110	54	36	6
0010111	23	17	ETB	0110111	55	37	7
0011000	24	18	CNL	0111000	56	38	8
0011001	25	19	EM	0111001	57	39	9
0011010	26	1A	SUB	0111010	58	3A	:
0011011	27	1B	ESC	0111011	59	3B	;
0011100	28	1C	FS	0111100	60	3C	<
0011101	29	1D	GS	0111101	61	3D	=
0011110	30	1E	RS	0111110	62	3E	>
0011111	31	1F	US	0111111	63	3F	?

8.2 ASCII code table (continued)

Binary	Decimal	Hexadecimal	Character	Binary	Decimal	Hexadecimal	Character
1000000	64	40	@	1100000	96	60	`
1000001	65	41	A	1100001	97	61	a
1000010	66	42	B	1100010	98	62	b
1000011	67	43	C	1100011	99	63	c
1000100	68	44	D	1100100	100	64	d
1000101	69	45	E	1100101	101	65	e
1000110	70	46	F	1100110	102	66	f
1000111	71	47	G	1100111	103	67	g
1001000	72	48	H	1101000	104	68	h
1001001	73	49	I	1101001	105	69	i
1001010	74	4A	J	1101010	106	6A	j
1001011	75	4B	K	1101011	107	6B	k
1001100	76	4C	L	1101100	108	6C	l
1001101	77	4D	M	1101101	109	6D	m
1001110	78	4E	N	1101110	110	6E	n
1001111	79	4F	O	1101111	111	6F	o
1010000	80	50	P	1110000	112	70	p
1010001	81	51	Q	1110001	113	71	q
1010010	82	52	R	1110010	114	72	r
1010011	83	53	S	1110011	115	73	s
1010100	84	54	T	1110100	116	74	t
1010101	85	55	U	1110101	117	75	u
1010110	86	56	V	1110110	118	76	v
1010111	87	57	W	1110111	119	77	w
1011000	88	58	X	1111000	120	78	x
1011001	89	59	Y	1111001	121	79	y
1011010	90	5A	Z	1111010	122	7A	z
1011011	91	5B	[1111011	123	7B	{
1011100	92	5C	\(¥)	1111100	124	7C	
1011101	93	5D]	1111101	125	7D	}
1011110	94	5E	^	1111110	126	7E	~
1011111	95	5F	_	1111111	127	7F	DEL

8.3 14 segment displays and 7 segment displays

The following are some examples of 14 segment displays and 7 segment displays as shown on the LCD of this product.

(example of 14 segment display)

A B C D E F G H I J K L M N O

P Q R S T U V W X Y Z

1 2 3 4 5 6 7 8 9 0 + - _ /

(example of 7 segment display)

A B C D

1 2 3 4 5 6 7 8 9 0 -

OMRON Corporation Industrial Automation Company

Kyoto, JAPAN

Contact: www.ia.omron.com

Regional Headquarters

OMRON EUROPE B.V.

Wegalaan 67-69, 2132 JD Hoofddorp
The Netherlands

Tel: (31)2356-81-300/Fax: (31)2356-81-388

OMRON ELECTRONICS LLC

2895 Greenspoint Parkway, Suite 200
Hoffman Estates, IL 60169 U.S.A.

Tel: (1) 847-843-7900/Fax: (1) 847-843-7787

OMRON ASIA PACIFIC PTE. LTD.

No. 438A Alexandra Road # 05-05/08 (Lobby 2),
Alexandra Technopark,
Singapore 119967

Tel: (65) 6835-3011/Fax: (65) 6835-2711

OMRON (CHINA) CO., LTD.

Room 2211, Bank of China Tower,
200 Yin Cheng Zhong Road,
PuDong New Area, Shanghai, 200120, China

Tel: (86) 21-5037-2222/Fax: (86) 21-5037-2200

Authorized Distributor:

© OMRON Corporation 2016-2023 All Rights Reserved.
In the interest of product improvement,
specifications are subject to change without notice.

Cat. No. N214-E1-04

0323