

GD Series

IO-Link Master Unit (CC-Link IE Field/TSN Compatible)

User's Manual

GD-ILM□□□-CLI

IO-Link Master Unit



NOTE

- All rights reserved. No part of this publication may be reproduced, stored in a retrieval system, or transmitted, in any form, or by any means, mechanical, electronic, photocopying, recording, or otherwise, without the prior written permission of OMRON.
- No patent liability is assumed with respect to the use of the information contained herein. Moreover, because OMRON is constantly striving to improve its high-quality products, the information contained in this manual is subject to change without notice.
- Every precaution has been taken in the preparation of this manual. Nevertheless, OMRON assumes no responsibility for errors or omissions. Neither is any liability assumed for damages resulting from the use of the information contained in this publication.

Trademarks

- Microsoft, Windows, Excel, Visual Basic, and Microsoft Edge are either registered trademarks or trademarks of Microsoft Corporation in the United States and other countries.
- CC-Link IE Field and CC-Link IE TSN are registered trademarks of Mitsubishi Electric Corporation managed by the CC-Link Partner Association.
- GX Works is a registered trademark or trademark of Mitsubishi Electric Corporation in Japan and other countries.

Other company names and product names in this document are the trademarks or registered trademarks of their respective companies.

Copyrights

- Microsoft product screen shots used with permission from Microsoft.

Introduction

Thank you for purchasing the IO-Link Master Units GD-ILM16C-CLI and GD-ILM16E-CLI.

This manual contains essential information for using the IO-Link Master Units GD-ILM16C-CLI and GD-ILM16E-CLI.

Please read this manual and make sure you understand the functionality and performance of the product before you attempt to build a system. After reading the manual, keep it in a safe and accessible location for further reference.

- Trademarks and registered trademarks appearing in this manual are the property of their respective owners.

Intended Audience

This manual is intended for the following personnel, who must also have knowledge of electrical systems (an electrical engineer or the equivalent).

- Personnel in charge of introducing FA systems.
- Personnel in charge of designing FA systems.
- Personnel in charge of installing and maintaining FA systems.
- Personnel in charge of managing FA systems and facilities.

Applicable Products

This manual covers the following product.

- GD-series IO-Link Master Unit
 - GD-ILM16C-CLI
 - GD-ILM16E-CLI

Manual Structure

Page Structure

The following page structure is used in this manual.

The diagram illustrates the structure of a manual page. It shows a page with the following elements and their corresponding annotations:

- Level 1 heading:** 2 Installation, Wiring and Front Panel Operation for Initial Settings
- Level 2 heading:** 2-1 Installing on a DIN Rail
- Level 3 heading:** 2-1-1 Installation Method
- Section Header:** Installation Procedure
- Text:** Follow the steps below to install this product.
- Steps in a procedure:**
 - 1 Hook the upper hook on the back of the product to the DIN rail.
 - 2 Push the lower side from the front.
 - 3 Push the DIN rail mounting hook up to lock the product in place.
- Diagram:** A technical drawing showing the product being installed on a DIN rail. Labels include 'DIN Track', 'Push-in', and 'DIN rail mounting hook'.
- Section Header:** Removal Procedure
- Text:** Follow the steps below to uninstall.
- Steps in a procedure:**
 - 1 While pushing down the DIN rail mounting hook, pull it forward from the bottom. The lower hook on the back of this product will come off from the DIN rail.
 - 2 Remove the upper side of this product from the DIN rail.
- Section Header:** Additional Information
- Special information:**
 - This product cannot be screw-mounted.
 - Install this product at least 10 mm away from an adjacent device and structure.
 - Remove the power supply wires during installation. In particular, make sure this product and the IO-Link device are not powered when interconnecting or removing them.
- Manual name:** GD Series IO-Link Master Unit (CC-Link IE Field/TSN Compatible) User's Manual (Z513)
- Page number:** 2-2

This illustration is provided only as a sample. It may not literally appear in this manual.

Special Information

Special information in this manual is classified as follows:

Important

This summarizes particularly important points about its performance, including the things to be observed during operation and the advice on usage.



Additional Information

Additional information to read as required.

This information is provided to increase understanding or make operation easier.



Version Information

Information on differences in specifications and functionality for products with different unit versions and for different versions of the Support Software is given.

Notations Used in this Manual

These are the notations used in this manual.



Precautions for Correct Use

This indicates particularly important points to observe during operation.



Additional Information

This information is useful for operation.

Sections in this Manual

1	Overview	1
2	Installation, Wiring, and Front Operation for Initial Settings	2
3	Communication	3
4	Product Functions	4
5	Front Panel Controls	5
6	Specifications	6
7	Troubleshooting	7
A	Appendices	A
I	Index	I

CONTENTS

Introduction	1
Intended Audience	1
Applicable Products	1
Manual Structure.....	2
Page Structure	2
Special Information	2
Notations Used in this Manual	3
Sections in this Manual	5
Terms and Conditions Agreement.....	9
Warranty, Limitations of Liability	9
Application Considerations	10
Disclaimers	10
Statement of security responsibilities for assumed use cases and against threats.....	11
Safety Precautions.....	12
Definition of Precautionary Information.....	12
Symbols	12
Warning.....	12
Precautions for Safe Use	14
Precautions for Correct Use	15
Regulations and Standards	16
Conformance to EU Directives	16
Checking the Included Items	17
Items Included with This Product.....	17
Other Required Items	17
Related Manuals.....	18
Terminology.....	19
Revision History.....	22

Section 1 Overview

1-1 Product Overview	1-2
1-2 Part Names and Functions.....	1-4
1-2-1 Prior to Use	1-4
1-2-2 Part Names and Functions.....	1-5
1-3 Basic Procedures.....	1-8

Section 2 Installation, Wiring, and Front Operation for Initial Settings

2-1	Installing on a DIN Rail	2-2
2-2	Setting the Station Number	2-4
2-3	Wiring	2-5
2-3-1	Checking the Power Supply	2-5
2-3-2	Ethernet Connection	2-6
2-3-3	Module Power and I/O Power Supply Connections	2-7
2-4	Initial Settings for Front Panel Controls	2-14
2-4-1	Powering up the CC-Link IE Field/TSN Master Station.....	2-14
2-4-2	Language	2-14
2-4-3	I/O Assignment Settings.....	2-15

Section 3 Communication

3-1	Communication System Overview	3-2
3-2	Initial Setting of This Product via Software	3-3
3-2-1	Required Software	3-3
3-2-2	Procedure Overview.....	3-3
3-2-3	Reading the CSP+ File for This Product into GXWorks2/3	3-3
3-2-4	Registering This Product to CC IE Field Configurations or CC-Link IE TSN Configurations	3-8
3-2-5	Writing Settings to the CC-Link IE Field/TSN Master Station.....	3-11
3-2-6	Executing Parameter Processing to This Product from GXWorks2/3	3-13
3-2-7	Parameter Processing List from GXWorks2/3 to This Product	3-16
3-2-8	Error Code List when Executing Parameter Processing from GXWorks2/3.....	3-17
3-3	Setting Product Master Unit Parameters	3-19
3-3-1	Setting via GXWorks2/3	3-19
3-3-2	Setting via Front Panel Controls	3-19
3-3-3	Setting via Host Master Station Communication Instructions	3-19
3-4	CC-Link IE Field/TSN Communication and IO-Link Communication with This Product	3-20
3-4-1	Cyclic Communication (Cyclic Transmission/Process I/O Communication).....	3-20
3-4-2	Acyclic Communication (Transient Transmission/ISDU Communication)	3-31
3-4-3	Event Communication	3-37
3-5	Parameter Setting/Monitoring Inside IO-Link Devices	3-38
3-5-1	Reading/Writing IO-Link Device Data via Host Master Station Communication Instructions	3-38
3-5-2	Parameter Settings inside IO-Link Devices Connected to This Product, via Product Front Panel Operation.....	3-38
3-6	Specific Communication Examples (Including Sample Programs)	3-39
3-6-1	Example of Cyclic Communication.....	3-39
3-6-2	Example of Acyclic Communication	3-41

Section 4 Product Functions

4-1	Product Functions	4-2
------------	--------------------------------	------------

Section 5 Front Panel Controls

5-1	Front Panel Controls	5-2
5-1-1	Operating Window Overview.....	5-2
5-1-2	Process Data Display Window	5-3
5-1-3	Master Unit Parameters Window	5-5
5-1-4	Device Setting Value Window	5-6

5-1-5	Event/Error Display Window	5-8
-------	----------------------------------	-----

Section 6 Specifications

6-1	Specifications.....	6-2
6-2	Data Processing Time	6-5
6-2-1	Process Data Response Time Calculation	6-5
6-2-2	IO-Link Device Setting Value Access Time via IO-Link ISDU Communication	6-9
6-3	Dimensions.....	6-10
6-4	List of Product Master Unit Parameters	6-12
6-4-1	User Settings.....	6-12
6-4-2	Data for Access from PLC.....	6-28
6-4-3	Master Unit Parameter List with Product Front Panel Operation	6-38

Section 7 Troubleshooting

7-1	Troubleshooting.....	7-2
7-1-1	Troubleshooting Based on LEDs.....	7-2
7-1-2	Troubleshooting Based on Symptoms	7-4
7-1-3	Error Code List.....	7-8

Appendices

A-1	Acyclic Communication Sample Programs.....	A-2
A-1-1	For CC-Link IE Field.....	A-2
A-1-2	For CC-Link IE TSN	A-3

Index

Terms and Conditions Agreement

Warranty, Limitations of Liability

Warranties

- **Exclusive Warranty**

Omron's exclusive warranty is that the Products will be free from defects in materials and workmanship for a period of twelve months from the date of sale by Omron (or such other period expressed in writing by Omron). Omron disclaims all other warranties, express or implied.

- **Limitations**

OMRON MAKES NO WARRANTY OR REPRESENTATION, EXPRESS OR IMPLIED, ABOUT NON-INFRINGEMENT, MERCHANTABILITY OR FITNESS FOR A PARTICULAR PURPOSE OF THE PRODUCTS. BUYER ACKNOWLEDGES THAT IT ALONE HAS DETERMINED THAT THE PRODUCTS WILL SUITABLY MEET THE REQUIREMENTS OF THEIR INTENDED USE.

Omron further disclaims all warranties and responsibility of any type for claims or expenses based on infringement by the Products or otherwise of any intellectual property right.

- **Buyer Remedy**

Omron's sole obligation hereunder shall be, at Omron's election, to (i) replace (in the form originally shipped with Buyer responsible for labor charges for removal or replacement thereof) the non-complying Product, (ii) repair the non-complying Product, or (iii) repay or credit Buyer an amount equal to the purchase price of the non-complying Product; provided that in no event shall Omron be responsible for warranty, repair, indemnity or any other claims or expenses regarding the Products unless Omron's analysis confirms that the Products were properly handled, stored, installed and maintained and not subject to contamination, abuse, misuse or inappropriate modification. Return of any Products by Buyer must be approved in writing by Omron before shipment. Omron Companies shall not be liable for the suitability or unsuitability or the results from the use of Products in combination with any electrical or electronic components, circuits, system assemblies or any other materials or substances or environments. Any advice, recommendations or information given orally or in writing, are not to be construed as an amendment or addition to the above warranty.

See <https://www.omron.com/global/> or contact your Omron representative for published information.

Limitation on Liability; Etc

OMRON COMPANIES SHALL NOT BE LIABLE FOR SPECIAL, INDIRECT, INCIDENTAL, OR CONSEQUENTIAL DAMAGES, LOSS OF PROFITS OR PRODUCTION OR COMMERCIAL LOSS IN ANY

WAY CONNECTED WITH THE PRODUCTS, WHETHER SUCH CLAIM IS BASED IN CONTRACT, WARRANTY, NEGLIGENCE OR STRICT LIABILITY.

Further, in no event shall liability of Omron Companies exceed the individual price of the Product on which liability is asserted.

Application Considerations

Suitability of Use

Omron Companies shall not be responsible for conformity with any standards, codes or regulations which apply to the combination of the Product in the Buyer's application or use of the Product. At Buyer's request, Omron will provide applicable third party certification documents identifying ratings and limitations of use which apply to the Product. This information by itself is not sufficient for a complete determination of the suitability of the Product in combination with the end product, machine, system, or other application or use. Buyer shall be solely responsible for determining appropriateness of the particular Product with respect to Buyer's application, product or system. Buyer shall take application responsibility in all cases.

NEVER USE THE PRODUCT FOR AN APPLICATION INVOLVING SERIOUS RISK TO LIFE OR PROPERTY OR IN LARGE QUANTITIES WITHOUT ENSURING THAT THE SYSTEM AS A WHOLE HAS BEEN DESIGNED TO ADDRESS THE RISKS, AND THAT THE OMRON PRODUCT(S) IS PROPERLY RATED AND INSTALLED FOR THE INTENDED USE WITHIN THE OVERALL EQUIPMENT OR SYSTEM.

Programmable Products

Omron Companies shall not be responsible for the user's programming of a programmable Product, or any consequence thereof.

Disclaimers

Performance Data

Data presented in Omron Company websites, catalogs and other materials is provided as a guide for the user in determining suitability and does not constitute a warranty. It may represent the result of Omron's test conditions, and the user must correlate it to actual application requirements. Actual performance is subject to the Omron's Warranty and Limitations of Liability.

Change in Specifications

Product specifications and accessories may be changed at any time based on improvements and other reasons. It is our practice to change part numbers when published ratings or features are changed, or when significant construction changes are made. However, some specifications of the Product may

be changed without any notice. When in doubt, special part numbers may be assigned to fix or establish key specifications for your application. Please consult with your Omron's representative at any time to confirm actual specifications of purchased Product.

Errors and Omissions

Information presented by Omron Companies has been checked and is believed to be accurate; however, no responsibility is assumed for clerical, typographical or proofreading errors or omissions.

Statement of security responsibilities for assumed use cases and against threats

OMRON SHALL NOT BE RESPONSIBLE AND/OR LIABLE FOR ANY LOSS, DAMAGE, OR EXPENSES DIRECTLY OR INDIRECTLY RESULTING FROM THE INFECTION OF OMRON PRODUCTS, ANY SOFTWARE INSTALLED THEREON OR ANY COMPUTER EQUIPMENT, COMPUTER PROGRAMS, NETWORKS, DATABASES OR OTHER PROPRIETARY MATERIAL CONNECTED THERETO BY DISTRIBUTED DENIAL OF SERVICE ATTACK, COMPUTER VIRUSES, OTHER TECHNOLOGICALLY HARMFUL MATERIAL AND/OR UNAUTHORIZED ACCESS.

It shall be the users sole responsibility to determine and use adequate measures and checkpoints to satisfy the users particular requirements for (i) antivirus protection, (ii) data input and output, (iii) maintaining a means for reconstruction of lost data, (iv) preventing Omron Products and/or software installed thereon from being infected with computer viruses and (v) protecting Omron Products from unauthorized access.

Safety Precautions

This manual uses the following symbols to display safety precautions for ensuring safe operation of the IO-Link Master Unit GD-ILM16C-CLI and GD-ILM16E-CLI (hereafter, *this product*).

Precautions listed here describe important information about safety. Make sure to follow them accordingly.

Definition of Precautionary Information

The indications and their meanings are as follows.

 WARNING	<p>Indicates a potentially hazardous situation which, if not avoided, could result in death or serious injury. Additionally, there may be severe property damage.</p>
--	---

Symbols



The ○ and slash symbol indicates operations that you must not do. The specific operation is shown in the ○ and explained in text. This example indicates a prohibition of disassembly.



The ● symbol indicates operations that you must do. The specific operation is shown in the ● and explained in text. This example shows a general precaution for something that you must do.

Warning

WARNING

Do not disassemble, repair, modify, deform under pressure, or attempt to incinerate this product. Doing so may cause injury or fire.



Virus protection

Install and maintain the latest commercially available antivirus software on computers connected to control systems.



Prevention of unauthorized access

To prevent unauthorized access to OMRON products, implement the following measures.

- Introduction of physical controls that allow only authorized users to access control systems and equipment
- Prevention of access from untrusted devices by minimizing network connections to control systems and equipment
- Separation from IT networks through introduction of firewalls (blocking unused communications ports, restricting communications hosts)
- Use of virtual private networks (VPNs) when remote access to control systems and equipment is necessary
- Introduction of multi-factor authentication for remote access to control systems and equipment
- Use and frequent change of strong passwords
- Preliminary virus scanning for use of external storage devices such as USB memory sticks in control systems and equipment

**Protection of I/O data**

Confirm the validity of backup, range check, etc. in case of unintended modification of I/O data to control systems and equipment.

- Data range check
- Validation and preparation of backup and restore processes in case of data tampering or errors
- Safety design such as emergency stop and fallback operation in anticipation of data tampering and errors

**Restoration of lost data**

Periodically back up and maintain setting data as a measure against data loss.



When an intranet environment is used via a global address, connecting to an unauthorized terminal or server, such as SCADA or HMI, may result in network security issues such as spoofing or tampering. Take adequate measures on your own, such as restricting access to terminals, using terminals with secure functions, and locking the installation area.



When building an intranet, communications problems may occur due to cable disconnection or unauthorized network equipment.

Take adequate measures to restrict physical access to network equipment, for example, by locking the installation area.



Equipment with SD Memory Card functionality poses a security risk that a third party may remove or illegally unmount removable media to illegally acquire, tamper with, or replace files and data contained in them.

Take adequate measures on your own to restrict physical access to the Controller, for example, by locking the installation area, controlling entry to the room, or taking appropriate control measures for the removable media.

**Security Measures for Wave Inspire HUB**

- To prevent computer viruses, install antivirus software on a computer where you use this software.
Make sure to keep the antivirus software updated.
- Keep your computer's OS updated to avoid security risks caused by a vulnerability in the OS. Make sure that the user name and password for the OS or this software are properly set and managed to prevent unauthorized use by others.
- Always use the highest version of this software to add new features, increase operability, and enhance security.
- Set up a firewall (e.g., disabling unused communication ports, limiting communication hosts, etc.) on a network for a control system and devices to separate them from other IT networks.
- Use a virtual private network (VPN) for remote access to a control system and devices from this software.



Precautions for Safe Use

- Do not install this product or its cables in any of the following locations. Doing so may cause a fire, damage, or a malfunction.
 - a) Locations where dust, salt, iron powders, or vapor (steam) is present.
 - b) Locations subjected to corrosive gases, flammable gases, or explosive atmospheres.
 - c) Locations where water, oil, or chemical splashes may occur.
 - d) Locations where heavy vibrations or impacts may occur.
 - e) Locations where the ambient temperature exceeds the rated range.
 - f) Locations subject to rapid temperature changes (or where condensation occurs).
 - g) Locations with strong electric or magnetic fields.
 - h) Outdoor locations or locations subject to direct light.
- Field network communication is shut off
The process output data is held or cleared according to the *IO-Link and network error handling* of the Master Unit parameters in this product. It also holds or turns off PNP/NPN output data. At this time, take safety measures outside this product so that the system works on the safe side.
- After IO-Link communication has been shut off
If the IO-Link communication fails, the process input data is held or cleared according to the *IO-Link and network error handling* of the Master Unit parameters in this product. At this time, take safety measures outside this product so that the system works on the safe side.
- Do not use the product at voltages or with AC power supplies that exceed the rated voltage. Doing so may cause a fire or damage the product.
- If you detect any malfunction including emission of smoke, abnormal smells or sounds, or the body becoming very hot, immediately stop operating the product and turn off the power. Failure to do so can cause fire.
- Do not connect an actuator that does not support IO-Link to the port of this product set to IO-Link mode.
Depending on the operation of establishing IO-Link communication, the actuator may repeat ON/OFF operation with an unintended short cycle.

Precautions for Correct Use

- Do not use this product in water or in a location where it may be exposed to water. If water enters the product, immediately stop operating the product. Doing so may cause a fire or damage the product.
- When wiring this product, do so properly according to this manual and specified user's manuals. Incorrect wiring can cause product failure or malfunction.
- Use this product mounted on a DIN rail secured with the end plates (PFP-M) sold separately.
- Connect only specified cables to this product. Use of cables other than those specified can cause malfunction.
- If you notice an abnormal condition such as a strange odor, extreme heating of the unit, or smoke, immediately stop using the product, turn off the power, and consult your dealer.
- Make sure to attach the protective cap when the RJ45 connector of this product is not attached to a cable. When removing the RJ45 connector, do not touch the terminals inside the connector or allow foreign objects to get inside.
- Keep wiring separate from high voltage and motor circuits. Using the same wiring can cause malfunction or failure. If this is unavoidable, shield with a conductor such as an earthed conduit.
- Install this product as far away as possible from high-voltage equipment, equipment that generates large switching surges and equipment that generates noise, such as welding machines or inverter motors.
- Tighten the mounting screws for the power terminal block with a torque value of 0.25 N•m or less.
- Do not apply torsional stress to cables. Doing so can cause cables and connectors to malfunction. Fix communication cables connected to this product within lengths of 30 cm without applying stress to the product.
- Make sure to turn OFF the power before connecting or disconnecting cables and connectors, or replacing IO-Link devices. Connection or disconnection while running can cause malfunction.
- This product generates heat during operation, so do not maintain physical contact for long periods of time. Doing so can cause low-temperature burns, etc.
- Always hold the connector when connecting or disconnecting cables and do not apply excessive force to cables.
- When using power cables or commercially available switching regulators, make sure the frame ground (FG) is grounded.
- Make sure to use an isolation transformer for DC power supply. If a surge occurs in the power supply used, use a surge absorber for the source of generation.
-  Dispose in accordance with applicable regulations.
- Do not use this product in environments other than industrial environments. If used in other environments, it may cause induction and radiation interference.
- When the program in the host master station processes the process input data in IO-Link mode, make sure to confirm that the IO-Link Ready flag is ON before executing the program.
- Wait until after transient state (approx. 2 sec.) when power is turned ON before use.
- Do not exceed 1,000,000 writing operations of the EEPROM (non-volatile memory). Setting information is written to the EEPROM when setting changes are made.

Regulations and Standards

Conformance to EU Directives

This IO-Link Master Unit complies with EN61131-2.

The GD-series products comply with EU Directives. To ensure that the machine or device in which the GD-series products are used complies with EU Directives, the following precautions must be observed.

- You must use SELV and LIM circuits or UL 1310 Class 2 power supplies for the DC power supplies that are connected as the unit/input power supplies and output power supplies for the GD-series products. We recommend that you use the OMRON S8VK-S/S8VK-G-series Power Supplies.
- GD-series products that comply with EU Directives also conform to the Common Emission Standard. Radiated emission characteristics (10-m regulations) may vary depending on the configuration of the control panel used, other devices connected to the control panel, wiring, and other conditions. You must therefore confirm that the overall machine or equipment in which the GD-series products are used complies with EU Directives.

Checking the Included Items

Before you use this product, check the items included with it. If there are any defective or damaged items, please contact our customer support center (refer to the end of this manual).

Items Included with This Product

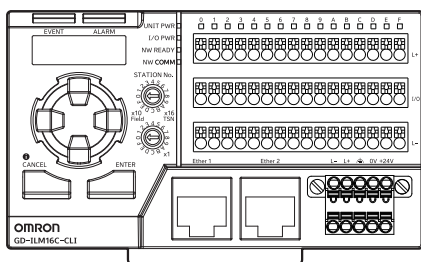

• GD-ILM16C-CLI unit

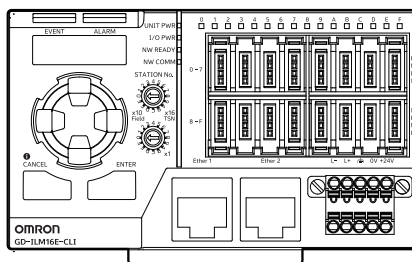

• GD-ILM16E-CLI unit

- Device terminal block x 3 (for GD-ILM16C-CLI only)
- Power terminal block
- RJ45 connector protective cap x 2 (attached to unit)
- Instruction Manual
- Compliance sheet

Note If the terminal block is lost or damaged, order the following model.

Device terminal block: GD-ILM16C-XP (contains 1)

Power terminal block: GD-ILM16-XV

Other Required Items

Cables

The following cables are used with this product.

Type	Specifications
Ethernet cable	<p>Ethernet cables that fulfill the following specifications</p> <ul style="list-style-type: none"> • Connector: RJ45 connector • For the cable, use an Ethernet cable that complies with a standard (1000BASE-T, 100BASE-TX, 10BASE-T). Refer to the user's manual of the host master station for further information.

Switching Hub

Use the following industrial switching hubs.

Type	Specifications
TSN hub	For the model name of the switching hub to be used and how to use it, check the CC-Link Partner Association website (https://www.cc-link.org).
General-purpose hub	In particular, when using CC-Link IE TSN, be sure to refer to the <i>CC-Link IE TSN Installation Manual</i> available from the CC-Link Partner Association website (https://www.cc-link.org).

Related Manuals

Manuals related to this manual are as follows. Reference them as needed.

Manual number	Manual name	Details
Z518	GD Series Wave Inspire HUB Operation Manual	Provides necessary information for operating OMRON Support Software (Wave Inspire HUB) for the GD Series.

Terminology

This explains the terminology used in this document.

Terminology	Description
Host master station	CC-Link IE Field communication or CC-Link IE TSN communication master station PLC
IO-Link Master Unit	OMRON's IO-Link Master Unit that supports CC-Link IE Field communication or CC-Link IE TSN communication. This device performs IO-Link communication with an IO-Link device in an IO-Link system but can also become a slave for communication with a master. This is referred to as <i>this product</i> within this document.
IO-Link Device	A slave device, such as a sensor or actuator, that can perform IO-Link communication with the IO-Link Master Unit.
SIO Device	This is an existing general-purpose I/O device that does not support IO-Link.
I/O Assignment Settings	Specifies the IO-Link communication or digital input/output operation with an external device (IO-Link device or SIO device) connected to the IO-Link Master Unit (this product). The following can be selected for each device to be connected. <ul style="list-style-type: none"> • IO-Link mode • PNP input mode • NPN input mode • PNP output mode • NPN output mode • Not used Note This product does not allow use of IO-Link specification Pin2 sink (PNP) input functions.
CC-Link IE Field/TSN	Indicates the general term for CC-Link IE Field communication and CC-Link IE TSN communication.
CC-Link IE Field/TSN master station	Station for controlling the entire CC-Link IE Field/TSN network. It can perform cyclic and acyclic communication with all stations. 1 unit exists per 1 network. For short, it is called the <i>host master station</i> .
CC-Link IE Field/TSN Master Unit	The general term for CC-Link IE Field Master Units and CC-Link IE TSN units.
Cyclic communication (cyclic transmission and process I/O communication)	The host master station regularly reads and writes the status/flag of this product and the process input/output data of the IO-Link device. This product executes process I/O communication (of IO-Link) with the IO-Link device.
Acyclic communication (transient transmission and ISDU communication)	When necessary, use the following communication instructions from the host master station to read and write the specified data in this product or device. When this happens, this product executes ISDU communication (of IO-Link) with the IO-Link device. <ul style="list-style-type: none"> • CC-Link IE Field communication: RIRD instructions (read), RIWT instructions (write) • CC-Link IE TSN communication: SLMPSND instructions
Process I/O communication	For IO-Link communication, cyclic communication will be used for requests from the IO-Link Master Unit to IO-Link devices.
ISDU communication	For IO-Link communication, acyclic communication will be used for requests from the IO-Link Master Unit to IO-Link devices.
Event communication	For IO-Link communication, acyclic communication will be used for notifications from IO-Link devices to the IO-Link Master Unit. When an event occurs on any IO-Link device, the event flag and up to the latest 6 event types/event codes of the IO-Link device on each port are stored in the <i>Event data read</i> of the Master Unit parameters of this product.
Communication cycle	This is a general term for the CC-Link IE Field communication link scan time and the CC-Link IE TSN communication cycle time.
Cycle time	Indicates the IO-Link communication cycle time.

Terminology	Description
Process input data	For IO-Link communication process I/O communication, cyclic data transmission will be used for data from IO-Link devices to the IO-Link Master Unit
Process output data	For IO-Link communication process I/O communication, cyclic data transmission will be used for data from the IO-Link Master Unit to IO-Link devices
Port	IO-Link Master Unit (this product) peripheral device connection port. Numbers from 0 to F (hexadecimal) are assigned in advance. However, the process input data and process output data of the connected IO-Link device must be a maximum of 256 words for the total of all ports used. Therefore, the following conditions are required to connect up to 16 IO-Link devices. Product process data size with the connected IO-Link device group: Input: Up to 256 words in total for all ports Output: Up to 256 words in total for all ports
Master Unit parameters	Data within this product that can be read and written by front operation of the unit, GXWorks2/3 or via acyclic communication using CC-Link IE Field/TSN.
Process data	Data from within the IO-Link device that can be read and written using IO-Link process I/O communication. General name for process input data or process output data.
Service data	Data from within the IO-Link device that can be read and written using IO-Link ISDU communication (acyclic).
Events	Shows events that occur within the IO-Link device. There are 3 types: notifications, errors and warnings.
Event code	Each IO-Link device event has an associated event (notification, error, warning) code. If the event flag is ON, the host master station can execute a communication instruction to read the event code. Alternatively, the event code can be checked using the event/error display window on the front of the product.
Errors	Refers to errors with this product. When an error occurs, the error code and the specified sub-index number that caused the error are stored in the <i>Latest error code for each port readout</i> field of the product's Master Unit parameters.
Error code	Error codes detected by the IO-Link Master Unit (this product). If the error flag is ON, the host master station can execute a communication instruction to read the error code. Alternatively, the error code can be checked using the event/error display window on the front of the product.
IO-Link ready flag	One type of process input data. A flag that turns ON when communicating with IO-Link devices on all connection ports and when CC-Link IE Field/TSN communication with the host master station is established.
Event flag	One type of process input data. A flag that turns ON when an event occurs on one or more IO-Link devices. The latest port in which the event occurred is stored in the latest event port.
Error flag	One type of process input data. A flag that turns ON when an error occurs on one or more IO-Link devices. The latest port in which the error occurred is stored in the latest error port.
Extended access	A communication method that allows the cyclic communication area to be used (without using acyclic communication) to read and write setting values. The following can be accessed. <ul style="list-style-type: none"> Any service data in any connected IO-Link device Master Unit parameters of this product
Byte length or target selection to access	Specify the target to access when extended access is enabled. <ul style="list-style-type: none"> IO-Link device connected to a port or the Master Unit parameters of this product (if so, specify the data size for simultaneous reading and writing)
Network synchronization	Synchronizes the IO-Link communication and digital I/O transfer of each port with the link scan time/communication cycle of the host CC-Link IE Field/TSN unit.
I/O synchronization	Synchronizes multiple port IO-Link communication or digital I/O transfer.

Terminology	Description
Process data sequence conversion	Converts the IO-Link device process data to little endian format or big endian format and transfers it to the CC-Link IE Field/TSN unit. Specify for each port.
Device verification	With IO-Link communication, process data is transferred only when the IO-Link device has the same registered revision ID, type ID, serial number, or type name. Specify for each port.
Revision ID	IO-Link protocol version implemented on the IO-Link device
Type ID	ID that identifies the model. A generic term for vendor ID and device ID.
Vendor ID	ID that identifies the manufacturer of the IO-Link device
Device ID	ID that identifies the model of the IO-Link device (consisting of one or more models)
IO-Link communication and network error handling	When CC-Link IE Field/TSN shuts down, IO-Link process output data is retained or cleared to zero. Alternatively, the PNP/NPN output data is held or turned OFF When IO-Link communication shuts down, IO-Link process input data is retained or cleared to zero. This provides a fail-safe. Specify in increments of IO-Link Master Unit (this product).
Input hold time	Holds ON for the specified time after the input signal turns ON. Specify for each port.
Input filter time	Configures the filter that removes input signal noise. Specify for each port.
Manual backup/restore of settings	Manually backs up/restores the parameters in the IO-Link device. Specify for each port.
Automatic storage (backup/restore) of settings	Automatically backs up/restores the parameters in the IO-Link device. Specify for each port.
Storage data	If the IO-Link device supports data storage functions, this is the parameter value in the IO-Link device that can be backed up to or listed from this product.
GXWorks2/3	A generic term for GX Works3 and GX Works2.
Remote device station	A station that uses cyclic transmission bit-based I/O signals and word-based I/O data to communication with a host master station. It can also return a response to transient transmissions (requests) from other stations.
Remote output (RY)	Information output from the CC-Link IE Field/TSN master station to the slave stations in bits. Link device type.
Remote input (RX)	Information input to the CC-Link IE Field/TSN master station from the slave station in bits. Link device type.
Remote register (RW _r)	Information input to the CC-Link IE Field/TSN master station from the slave station in 16 bit increments (1 word). Link device type.
Remote register (RW _w)	Information output from the CC-Link IE Field/TSN master station to the slave stations in 16 bit increments (1 word). Link device type.
Link device	Devices that make up the internals of a CC-Link IE Field/TSN network. Generic name for RX, RY, RW _r , and RW _w .
Wave Inspire HUB	This is OMRON's free Support Software that allows you to change settings and monitor process data for this product and connected IO-Link devices via Ethernet communication. It enables automatic collection of IODD files, managing setting information as projects, bulk writing of settings, and visualization of measured values and judgment results, and more.

Revision History

A manual revision code appears as a suffix to the catalog number on the front and back covers of the manual.

Cat. No. Z513-E1-02

↑
Revision code

Revision code	Date	Revised content
01	February 2026	Original production
02	April 2026	Corrected mistakes.



1

Overview

This section describes an overview of the IO-Link Master Unit (hereafter *this product*).

1-1	Product Overview	1-2
1-2	Part Names and Functions	1-4
1-2-1	Prior to Use	1-4
1-2-2	Part Names and Functions	1-5
1-3	Basic Procedures	1-8

1-1 Product Overview

This product is a slave station for CC-Link IE Field communication or CC-Link IE TSN communication (hereinafter collectively referred to as *CC-Link IE Field/TSN*) and is a remote I/O module equipped with the IO-Link Master Unit function.

Supports both cyclic and acyclic communication as a CC-Link IE Field communication unit or CC-Link IE TSN communication slave station.

As an IO-Link Master Unit, it supports both cyclic (process data) communication and acyclic (ISDU) communication. Event communication from IO-Link devices is also supported.

It can also be used to check and change settings, check process data, and check events using the front panel controls.

Moreover, using OMRON Support Software Wave Inspire HUB for free, it is possible to change settings and monitor process data for this product and connected IO-Link devices.

Note However, this is possible only when *M2. Network type* is set to *CC-Link IE TSN*. When it is set to *CC-Link IE Field Basic*, the Support Software cannot be connected.

CC-Link IE Field/TSN and IO-Link System Configuration Example

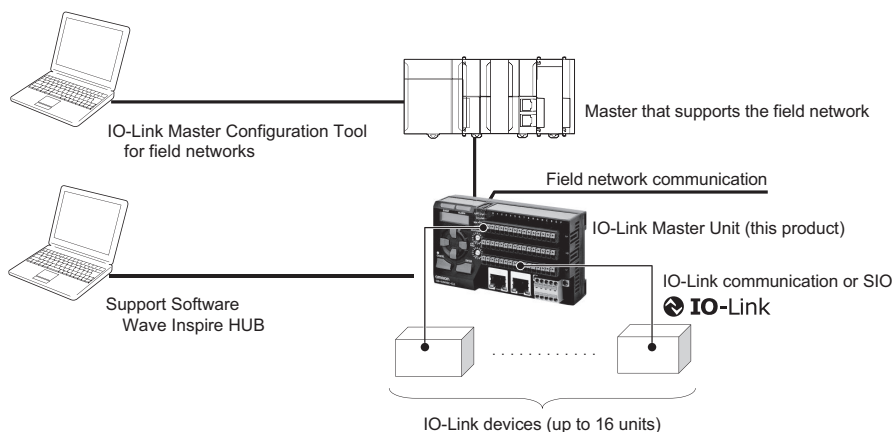

Note The following conditions are required to connect up to 16 IO-Link devices to this product.

Product process data size with the connected IO-Link device group:

Input: Up to 256 words in total for all ports

Output: Up to 256 words in total for all ports

Features

- No. of IO-Link ports: Up to 16 units.
- NPN device connection is possible with SIO. Mixed connection of NPN devices and PNP devices is possible. Moreover, the output is equipped with an overcurrent protection circuit.
- IO-Link communication can be processed with independent hardware logic to achieve cycle time greater than standard, as fast as 0.3 ms.
- IO-Link acyclic (ISDU) communication is possible.
- CC-Link IE Field communication or CC-Link IE TSN communication can be switched between as the host communication method.

- A time stamp can also be added to the process input data. As a result, CC-Link IE TSN makes it possible to read the time when the process input data was taken from this machine, as synchronized with the network time, with a resolution of 15.26 μ s.
Additionally, adding parity information calculated from process input data and time information, it is possible to ensure the integrity of process input data and time (data integrity: DI).
It is also possible to store the read time of the setting value from the IO-Link device within this product and later read it from the host PLC.
- A rotary encoder can be connected as an SIO device to this product, and the high-speed counter current value on the process data side can be sent to the host network master.
- The organic display and operation buttons enable the following actions from the front.
 - a) Master Unit parameter setting
 - b) I/O assignment status monitoring
 - c) Multiple languages supported (Japanese, English, Simplified Chinese, Traditional Chinese, Korean, German, French, Spanish, Portuguese, Italian)
- The type ID (vendor ID and device ID) of the IO-Link device can be saved in the unit, enabling the device connection and configuration to be verified. Furthermore, the serial number and type name can be verified.
- The IO-Link device settings can also be saved (as backups) on this product, enabling device settings that are saved prior to device replacement to be uploaded (restored) from this product to the replaced IO-Link device (both automatic and manual methods are available).

1-2 Part Names and Functions

1-2-1 Prior to Use

Assemble the power terminal block and device terminal blocks or e-CONs to the main unit as shown below.

Note For the GD-ILM16E-CLI devices, purchase OMRON e-CON plugs (XN2A) separately as they are not included.

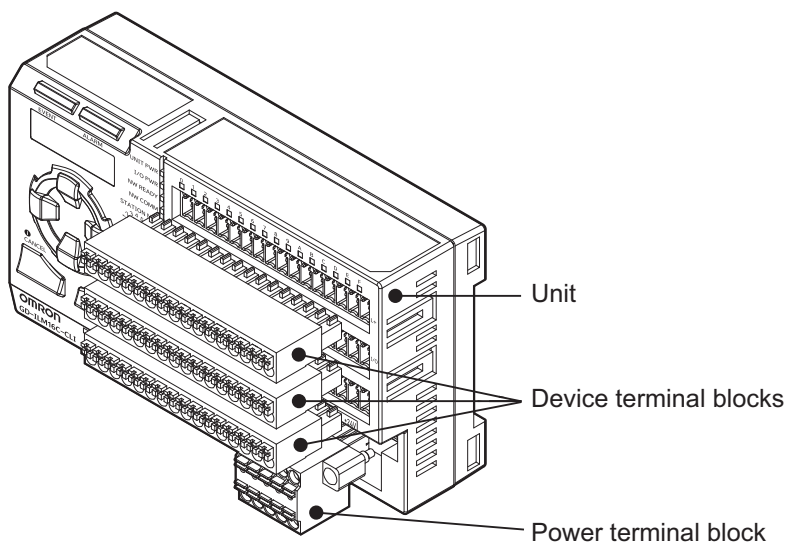

GD-ILM16C-CLI

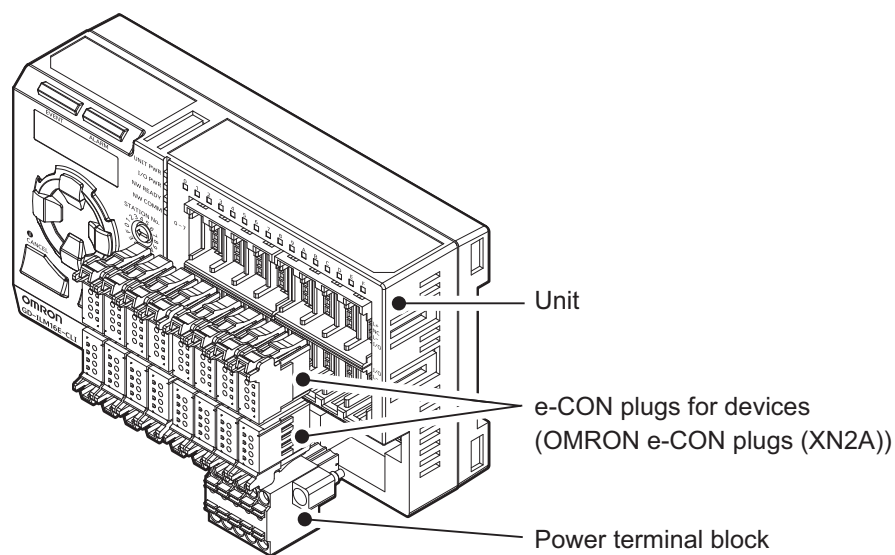

GD-ILM16E-CLI

1-2-2 Part Names and Functions

The names and functions of each part after assembling the terminal block are as follows.

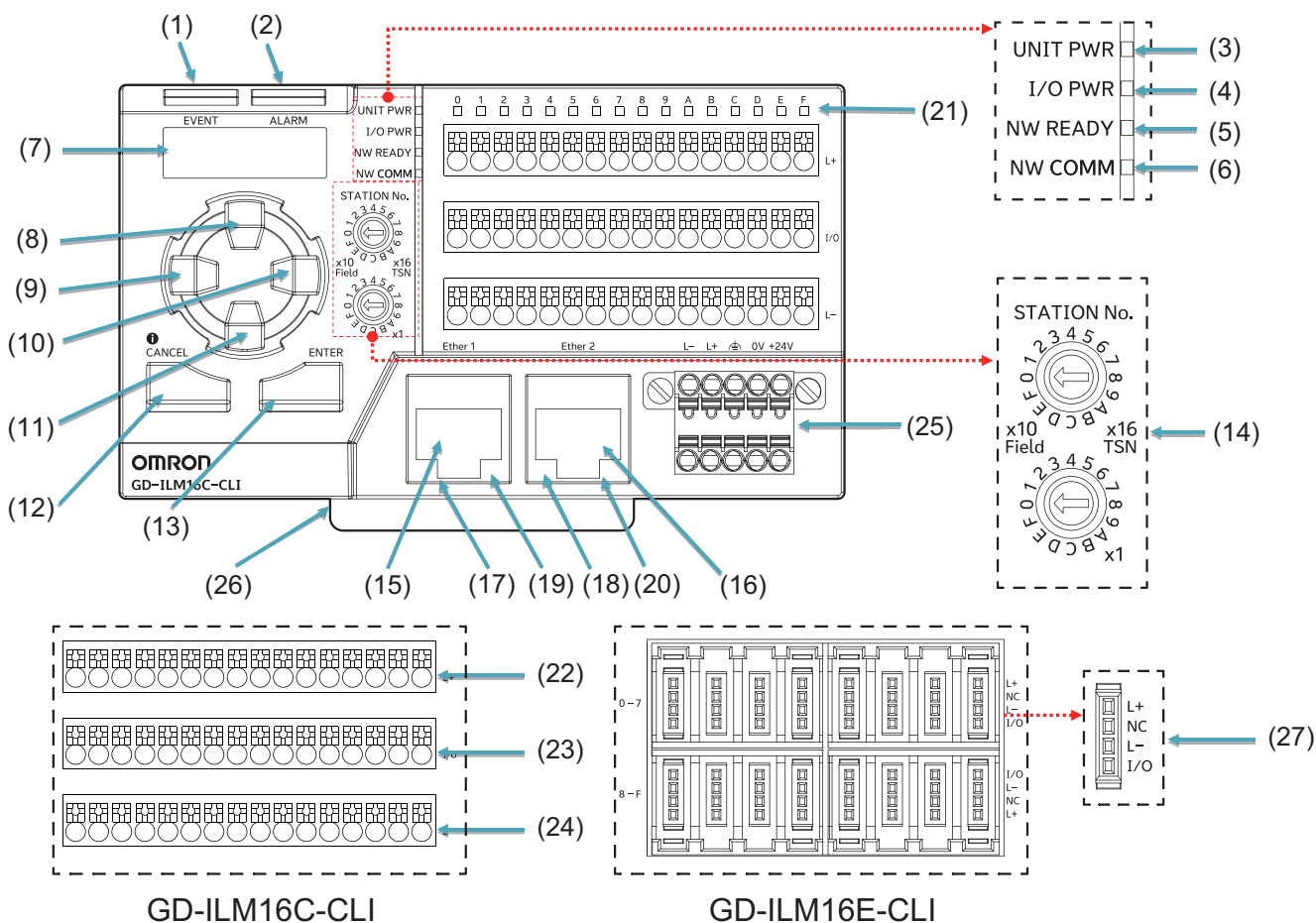

No.	Name	Details
(1)	EVENT LED (yellow)	Blinks while an event is occurring on one of the connected IO-Link devices. At this time, the <i>event flag</i> is turned ON. For details about <i>event flags</i> , refer to 3-4-1 Cyclic Communication (Cyclic Transmission/Process I/O Communication) on page 3-20.
(2)	ALARM LED (Red)	Blinks while this product is detecting an error. At this time, the <i>error flag</i> is turned ON. For details about <i>error flags</i> , refer to 3-4-1 Cyclic Communication (Cyclic Transmission/Process I/O Communication) on page 3-20.
(3)	UNIT PWR LED (Blue-green)	Light when the unit power of this product is supplied. Illuminated: power on Off: Power off or unit power supply voltage drop.
(4)	I/O PWR LED (Blue-green)	Indicates the power supply status of the I/O power supply. Illuminated: I/O power supply available (17 V or higher) Blinking: I/O voltage is in the range of 10 to 17 V. Off: No I/O power supply, or I/O voltage drop (less than 10 V).
(5)	NW READY LED (Blue-green)	Lights when the internal IC of CC-Link IE Field/TSN starts up.
(6)	NW COMM LED (Blue-green)	Displays the communication status of CC-Link IE Field/TSN. Illuminated: Normal communication Blinking: Communication interruption or network synchronization signal error Off: Not communicating

No.	Name	Details
(7)	Display	Displays various information. The display will turn off automatically after 10 minutes of inactivity. Press any button to resume the display. If the cumulative display drive time is 100 hours or less, the lights will not turn off automatically.
(8)	↑ button	Press at the following times. <ul style="list-style-type: none"> • To switch menu • To increase setting values • To switch to previous setting item • To switch the process data being displayed
(9)	← button	Press at the following times. <ul style="list-style-type: none"> • To switch to the previous port • Move the digit of the setting value to be changed to the left
(10)	→ button	Press at the following times. <ul style="list-style-type: none"> • To switch to the next port • Move the digit of the setting value to be changed to the right
(11)	↓ button	Press at the following times. <ul style="list-style-type: none"> • To switch menu • To decrease setting values • To switch to next setting item • To switch the process data being displayed
(12)	 /CANCEL button	Press at the following times. <ul style="list-style-type: none"> • To show help • Batch display of I/O assignment • Canceling setting value changes
(13)	ENTER button	Press at the following times. <ul style="list-style-type: none"> • Entering the setting value change mode • Confirming setting value changes • Clearing errors or events • Selecting menus and confirming
(14)	Station number setting switch	Set the station number of CC-Link IE Field or CC-Link IE TSN. For CC-Link IE Field, the top is the 10th place and the bottom is the 1st place. For CC-Link IE TSN, multiply the upper value by 16 and add it to the lower value. However, for CC-Link IE Field, the network number can be changed by turning on the power of this product and configuring the set value from the front, or by holding down the ENTER button with the correct station number set and turning on the unit to set automatically. With CC-Link IE TSN, it is necessary to set the network number on the product.
(15)	Ethernet connector Ether1	Ether1 and Ether2 connectors (RJ45 connectors) for CC-Link IE Field/TSN connection. Connect an Ethernet cable.
(16)	Ethernet connector Ether2	
(17)	LINK LED (green)	Light during the link-up of the CC-Link IE Field/TSN communication.
(18)	LINK LED (green)	
(19)	LER LED (yellow)	Illuminates in any of the following cases. <ul style="list-style-type: none"> • Light when receiving abnormal data of CC-Link IE Field or during loop-pack error.
(20)	LER LED (yellow)	

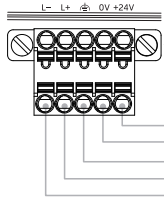
No.	Name	Details
(21)	0 to F LEDs (orange)	<p>Display the ON/OFF status of inputs or outputs.</p> <p>During IO-Link communication, the ON/OFF status of the least significant bit of the BOOL type data specified in the process input data or the same bit of the process output data is displayed (*1).</p> <p>Blinks if the PNP or NPN output is in an overcurrent state.</p> <p>*1. The contents of the process input data format with index number 14 and the process output data format with index number 15 in the IO-Link device are read, interpreted, and displayed.</p>
(22)	Device terminal block (L+)	<p>Supplies 24 VDC to input/output devices.</p> <p>The (25) terminal block I/O power supply L+ is connected internally.</p>
(23)	Device terminal block (I/O)	Supplies signals to input/output devices.
(24)	Device terminal block (L-)	<p>Supplies 0 V to input/output devices.</p> <p>This is internally connected to the I/O power L- terminal of (25) Power terminal block.</p>
(25)	Power terminal block (0V, +24V)	<p>Supplies unit power (+24V, 0V), FG, and I/O power (L+, L-).</p>  <p>← +24 V and 0 V terminals on the upper row can be used to supply power to L+ and L- in the left of upper row or other devices. The top and bottom terminals are connected internally.</p> <p>The bottom supplies each power supply.</p> <ul style="list-style-type: none"> Unit power supply +24 V Unit power supply 0 V FG (type 3 ground) I/O power supply L+ I/O power supply L-
(26)	DIN rail mounting hook	The part where the lower hook on the back of this product slides for attaching/removing the product to/from the DIN rail.
(27)	e-CON socket for device (4 poles)	<p>L+: Supplies 24 VDC to input/output devices.</p> <p>The (25) terminal block I/O power supply L+ is connected internally.</p> <p>L-: Supplies 0 V to input/output devices.</p> <p>This is internally connected to the I/O power L- terminal of (25) Power terminal block.</p> <p>I/O: Supplies signals to input/output devices.</p>

1-3 Basic Procedures

The procedures to install and configure this product and start the CC-Link IE Field/TSN or IO-Link communication are shown below.

Procedure	Details	References
Prior confirmation	System configuration decision: <ul style="list-style-type: none"> The host network uses either CC-Link IE Field communication or CC-Link IE TSN communication IO-Link device types and number used In particular, calculate the number of connectable IO-Link devices based on the total process data size of each IO-Link device (Related to the above) Determine whether to automatically allocate process data from the actual IO-Link device or manually set the number of input or output words for the IO-Link device for each port Each port I/O assignment settings 	<i>1-1 Product Overview</i> on page 1-2 <i>3-4-1 Cyclic Communication (Cyclic Transmission/Process I/O Communication)</i> on page 3-20 <i>3-3 Setting Product Master Unit Parameters</i> on page 3-19
	Data I/O design: <ul style="list-style-type: none"> What to read and write to this product or IO-Link device using process data (cyclic) communication? What to read and write to this product or IO-Link device using acyclic (transient/ISDU) communication? 	<i>Section 3 Communication</i> on page 3-1 <i>3-4 CC-Link IE Field/TSN Communication and IO-Link Communication with This Product</i> on page 3-20
Hardware installation and wiring	CC-Link IE Field/TSN master station mounting	Manual for the CC-Link IE Field/TSN master station used
	Assembling the included device terminal block x 3 and power terminal block x 1 to the main unit	<i>1-2 Part Names and Functions</i> on page 1-4
	Installing on a DIN rail	<i>2-1 Installing on a DIN Rail</i> on page 2-2
	Setting the station number using the rotary switch on the front of the product	<i>2-2 Setting the Station Number</i> on page 2-4
	CC-Link IE Field/TSN Ethernet cable wiring	<i>Ethernet Connection Status</i> on page 2-6
	IO-Link connection terminal wiring	<i>2-3-3 Module Power and I/O Power Supply Connections</i> on page 2-7
	Unit power supply wiring	<i>2-3-3 Module Power and I/O Power Supply Connections</i> on page 2-7
Initial setting via GXWorks 2/3	Register this product to the CC-Link IE Field/TSN network	<i>3-2-3 Reading the CSP+ File for This Product into GXWorks2/3</i> on page 3-3 <i>3-2-4 Registering This Product to CC IE Field Configurations or CC-Link IE TSN Configurations</i> on page 3-8
	Reading CSP+ files into GXWorks2/3	
	Using GXWorks2/3, registering this product to the CC-Link IE Field/TSN network configuration	
	CC-Link IE Field/TSN settings between this product and the CC-Link IE Field/TSN master station	

Procedure		Details	References
Master Unit parameter setting		Writing configuration contents to the CC-Link IE Field/TSN master station	3-2-5 <i>Writing Settings to the CC-Link IE Field/TSN Master Station</i> on page 3-11
		CC-Link IE Field/TSN established (NW COMM LED on the front of the unit illuminates green)	1-2 <i>Part Names and Functions</i> on page 1-4
		Setting Master Unit parameters using GXWorks2/3	3-2-6 <i>Executing Parameter Processing to This Product from GXWorks2/3</i> on page 3-13
		Writing to this product via CC-Link IE Field/TSN	3-2-5 <i>Writing Settings to the CC-Link IE Field/TSN Master Station</i> on page 3-11
Parameter settings of this product		Using GXWorks2/3	Refer to the previously mentioned <i>Initial setting via GXWorks2/3 procedure</i> 3-3-1 <i>Setting via GXWorks2/3</i> on page 3-19
		Using front panel controls	2-4 <i>Initial Settings for Front Panel Controls</i> on page 2-14 Section 5 <i>Front Panel Controls</i> on page 5-1
		Using OMRON Support Software Wave Inspire HUB Note Possible only when <i>M2. Network type</i> is set to <i>CC-Link IE TSN</i> .	Wave Inspire HUB Operation Manual
IO-Link device parameter setting		Using front panel controls	Section 5 <i>Front Panel Controls</i> on page 5-1
		Using host master station communication instructions	3-5-1 <i>Reading/Writing IO-Link Device Data via Host Master Station Communication Instructions</i> on page 3-38
Starting communication		Starting system (power ON)	
		Starting CC-Link IE Field/TSN Starting IO-Link communication	Manual for the CC-Link IE Field/TSN master station used
Checking operation		Verifying CC-Link IE Field/TSN master station or this product/IO-Link device display	Manual for the CC-Link IE Field/TSN master station used 1-2 <i>Part Names and Functions</i> on page 1-4 and 7-1 <i>Troubleshooting</i> on page 7-2 Each IO-Link device manual
		Verifying read/write data between this product and an IO-Link device	Each IO-Link device manual
		Verifying CC-Link IE Field/TSN master station reads/writes data via cyclic communication to/from this product	Manual for the CC-Link IE Field/TSN master station used
		Reading and writing to this product or IO-Link device (when required) using acyclic (transient/ISDU) communication Execute the following communication instructions of the PLC: <ul style="list-style-type: none"> • CC-Link IE Field communication: RIRD instructions (read), RIWT instructions (write) • For CC-Link IE TSN communication: SLMPSND instructions 	3-4-2 <i>Acyclic Communication (Transient Transmission/ISDU Communication)</i> on page 3-31

Procedure	Details	References
Troubleshooting	Verifying CC-Link IE Field/TSN master station or this product/IO-Link device display, Verifying cyclic communication (transient/ISDU) communication response	<i>Section 7 Troubleshooting</i> on page 7-1



Additional Information

The Master Unit parameter values of this product and the setting values of the connected IO-Link device can be changed using any of the following three methods. The applications of each are as follows.

Method	Main application	References
1) Unit front operation	Maintenance	<ul style="list-style-type: none"> • <i>2-4 Initial Settings for Front Panel Controls</i> on page 2-14 • <i>Section 5 Front Panel Controls</i> on page 5-1
2) Parameter processing from GXWorks2/3		<ul style="list-style-type: none"> • <i>3-2-6 Executing Parameter Processing to This Product from GXWorks2/3</i> on page 3-13 • <i>3-2-7 Parameter Processing List from GXWorks2/3 to This Product</i> on page 3-16
3) Acyclic communication from the host master station	Controlled operation	<ul style="list-style-type: none"> • <i>3-4-2 Acyclic Communication (Transient Transmission/ISDU Communication)</i> on page 3-31 • <i>3-6-2 Example of Acyclic Communication</i> on page 3-41 • <i>3-3 Setting Product Master Unit Parameters</i> on page 3-19



Precautions for Correct Use

- If more than 256 words are used on either the input or the output in total, the excess process data will not be assigned to the host master station (and will be ignored).
The following conditions are required to connect up to 16 IO-Link devices to this product.
Product process data size with the connected IO-Link device group:
Input: Up to 256 words in total for all ports
Output: Up to 256 words in total for all ports
- When the IO-Link ready flag is ON, read and write process data.

2

Installation, Wiring, and Front Operation for Initial Settings

This section describes the installation of this product, station number setting, communication connection, power supply wiring, and initial settings for front operation of this product.

2-1	Installing on a DIN Rail	2-2
2-2	Setting the Station Number	2-4
2-3	Wiring	2-5
2-3-1	Checking the Power Supply	2-5
2-3-2	Ethernet Connection	2-6
2-3-3	Module Power and I/O Power Supply Connections	2-7
2-4	Initial Settings for Front Panel Controls	2-14
2-4-1	Powering up the CC-Link IE Field/TSN Master Station	2-14
2-4-2	Language	2-14
2-4-3	I/O Assignment Settings	2-15

2-1 Installing on a DIN Rail

Install this product to a DIN rail.



Additional Information

- Install this product at least 10mm away from an adjacent device and structure.
- Remove the power supply cable during installation. In particular, make sure this product and the IO-Link device are not powered when interconnecting or removing them.

Installation Procedure

Follow the steps below to install this product.

- 1** Hook the upper hook on the back of the product to the DIN rail.
- 2** Push the lower side from the front.
- 3** Push the DIN rail mounting hook up to lock the product in place.

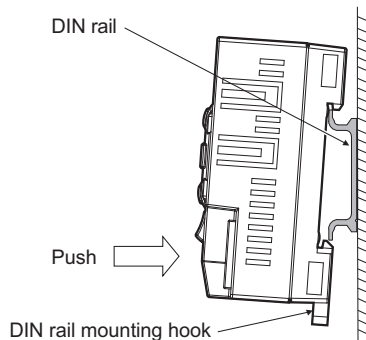

Removal Procedure

Follow the steps below to uninstall.

- 1** While pushing down the DIN rail mounting hook, pull it forward from the bottom. The lower hook on the back of this product will come off from the DIN rail.
- 2** Remove the upper side of this product from the DIN rail.

Important

- What to do if the DIN rail mounting hook comes off
If the DIN rail mounting hook comes off when removing this product, slide it back into place from the bottom to restore it its original state.

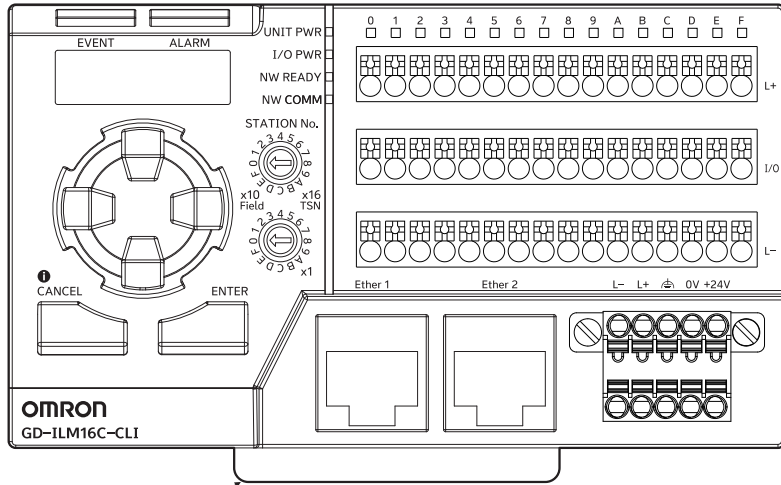

DIN rail mounting hook



Mounting (sliding) direction of DIN rail mounting hook

2-2 Setting the Station Number

Before turning the power supply ON, configure the station number (Station No.) of this product that will be used as the host network CC-Link IE Field/TSN slave using the rotary switch on the front panel.

Station number setting rotary switches

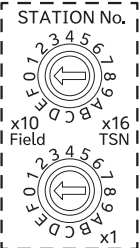
	For CC-Link IE Field	For CC-Link IE TSN
	<p>The value of upper switch represents tens digit of station number.</p> <p>The value of lower switch represents ones digit of station number.</p>	<p>Add the value of upper switch multiplied by 16 and the value of lower switch.</p>

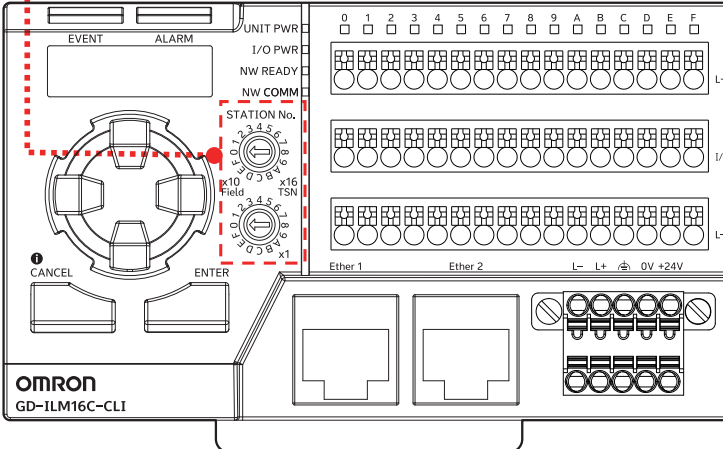

Note The above figure is for GD-ILM16C-CLI. The same applies to GD-ILM16E-CLI.

Set the CC-Link IE communication station number.

- For CC-Link IE Field, the top is the 10th place and the bottom is the 1st place.
- For CC-Link IE TSN, multiply the upper value by 16 and add it to the lower value.

For example, if only the host master station and this product are used, the station number is 1 in both cases. Set the upper switch to 0 and the lower switch to 1.

However, for CC-Link IE Field, the network number can be changed by turning on the power of this product and configuring the set value from the front, or by holding down the **ENTER** button with the correct station number set and turning on the unit to set automatically.

With CC-Link IE TSN, it is not necessary to set the network number.

CC-Link IE Field is selected as the network in the factory setting. To switch easily to CC-Link IE TSN, hold down the **ENTER** button at the factory setting while powering ON this product.

The language selection screen will be displayed; select a language. Thereafter, the setting will automatically switch to CC-Link IE TSN. Without turning the power OFF, wait until it restarts.

2-3 Wiring

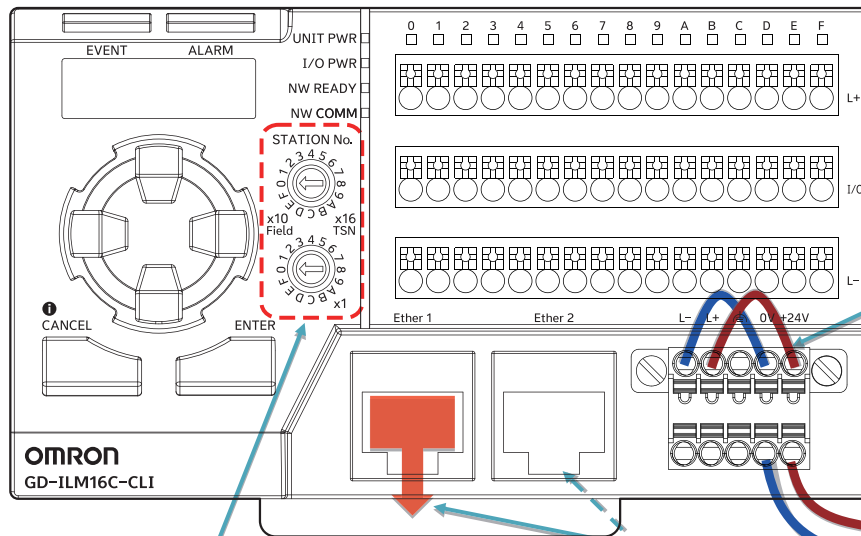

Before turning the power supply ON, connect the CC-Link IE Field or CC-Link IE TSN unit and configure the station number (Station No.) to be used using the rotary switch.

Connect an Ethernet cable to the CC-Link IE Field (or CC-Link IE TSN) master station. It can be connected to either the left or right.

Wired when connecting the unit power supply (+24 V, 0 V) and the I/O power supply (L+, L-) in parallel (*1)

Connect a 24 VDC power supply. This shows the unit power supply (+24 V, 0 V) and the I/O power supply (L+, L-) connected in parallel (*1)

Note 1. The above figure is for GD-ILM16C-CLI. The same applies to GD-ILM16E-CLI.

Note 2. For details on the wires used, please refer to *Wiring to The Power Terminal Block* on page 2-7 and *Wire to be Used* on page 2-11.

2-3-1 Checking the Power Supply

Turn on the power and check that the *UNIT PWR* (power supply indicator) and *I/O PWR* (I/O power supply indicator) LEDs are illuminated. If they do not light up, check the power supply and wiring. If the *I/O PWR* (I/O power supply indicator) LED is blinking, it indicates that the power supply voltage is low (less than 17 V).

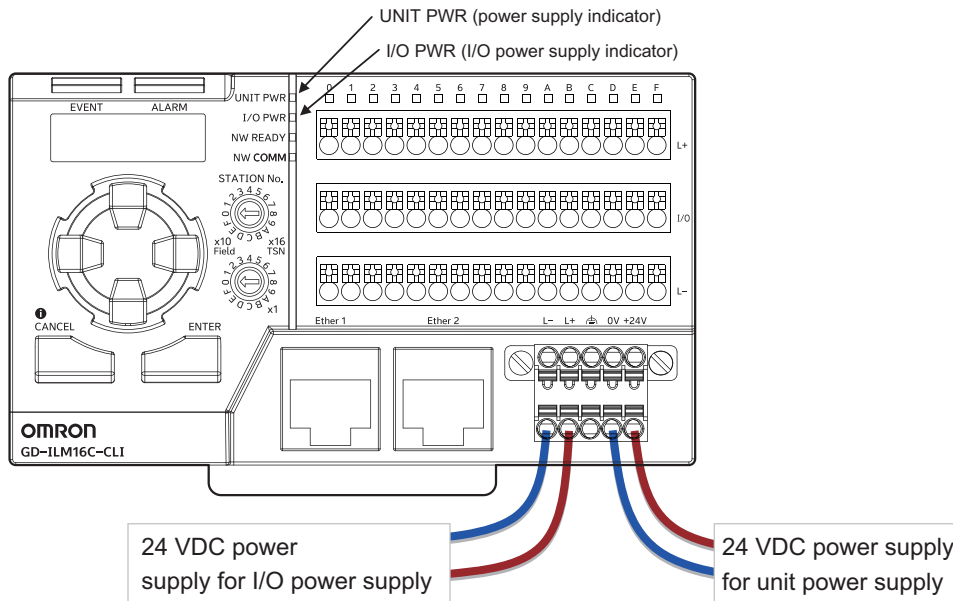

2-3-2 Ethernet Connection

Connector and Cable

The Ethernet cable can be connected to either the left or right RJ45 connector of this product. For the cable, use an Ethernet cable that complies with a standard (1000BASE-T, 100BASE-TX, 10BASE-T).

Refer to the user's manual of the host master station for further information.

Ethernet Connection Status

● Using CC IE Field

The possible topologies for CC IE Field are as follows.

This product also supports the following as a slave.

- Line connection
- Star connection
- Mixed star connection and line connection
- Ring connection

Refer to the user's manual of the host master station for further information.

● Using CC-Link IE TSN

The possible topologies for CC-Link IE TSN are as follows.

This product also supports the following as a slave.

- Line connection
- Star connection
- Mixed star connection and line connection

Refer to the user's manual of the host master station for further information. Also be sure to refer to the *CC-Link IE TSN Installation Manual* available from the CC-Link Partner Association website (<https://www.cc-link.org>).

2-3-3 Module Power and I/O Power Supply Connections

Internal Circuit Diagram of This Product

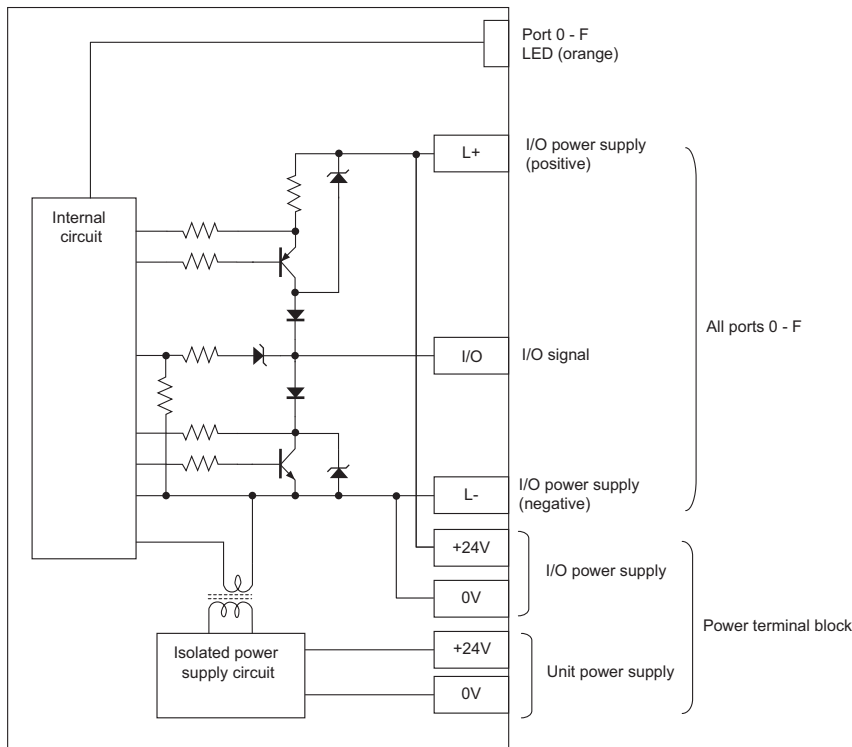

Wiring to The Power Terminal Block

Supplies unit power and I/O power to the power terminal block of this product.

Short-circuit the top terminals when sharing the unit power supply and the input/output power supply.

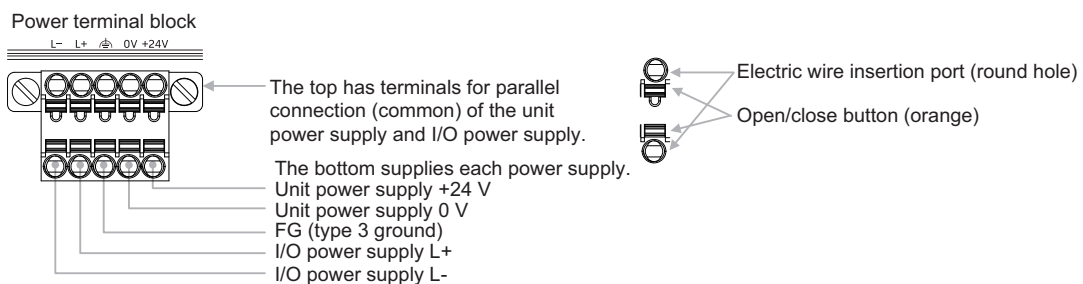

Additional Information

For the wires to be used and recommended ferrules, refer to *Wire Installation* on page 2-10 through *Recommended Ferrule and Crimping Tool* on page 2-11.

Install the ferrite core, NFT-13S made by TAKEUCHI INDUSTRY CO., LTD., that is included in the product package, to the cables connected to Unit Power Supply terminals. Wrap the power cables around the ferrite core as shown in the figure below.

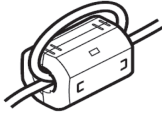

Wiring to Device Terminal Block or e-CON

● For GD-ILM16C-CLI

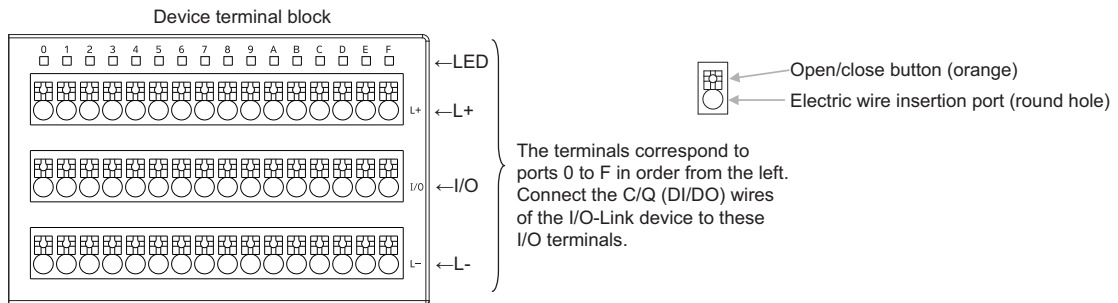

Additional Information

For the wires to be used and recommended ferrules, refer to *Wire Installation* on page 2-10 through *Recommended Ferrule and Crimping Tool* on page 2-11.

● For GD-ILM16E-CLI

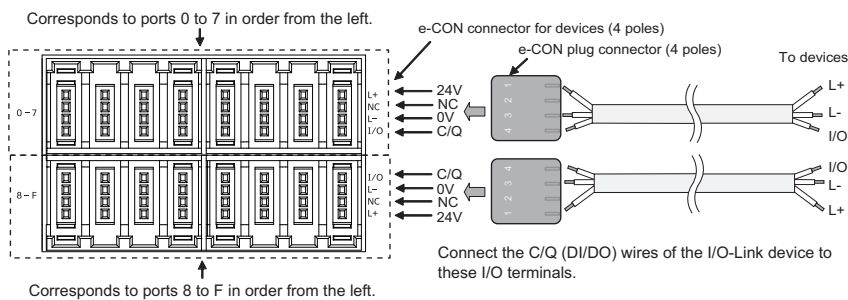

Applicable wires should be with a temperature rating of 75°C or higher. And, match the wire size to the e-CON plug specifications.

● IO-Link Communication Wiring

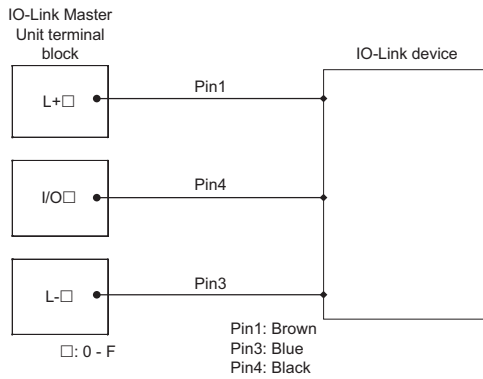

● Wiring for SIO (PNP Input)

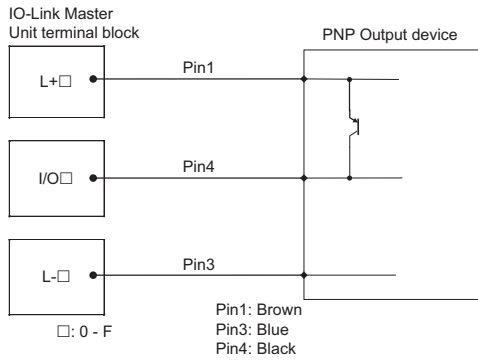

● Wiring for SIO (NPN Input)

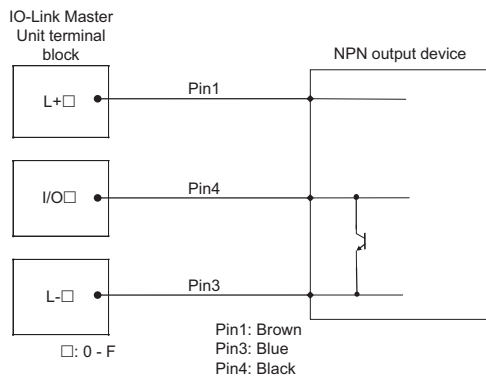

● **Wiring for SIO (PNP Output)**

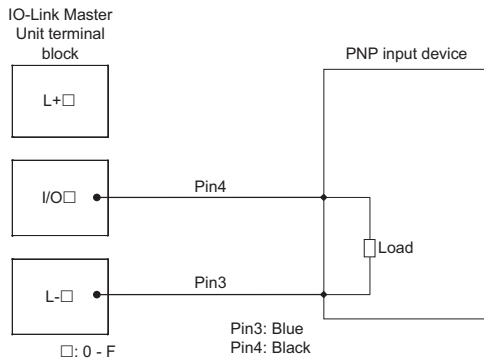

● **Wiring for SIO (NPN Output)**

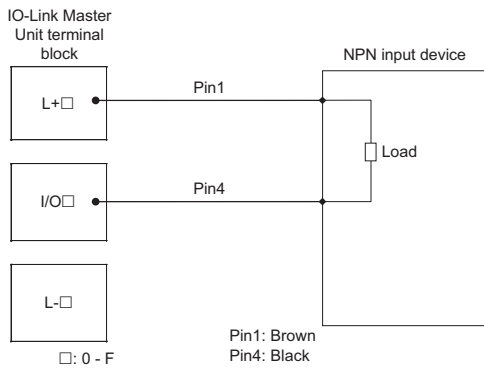

● **Rotary Encoder Wiring**

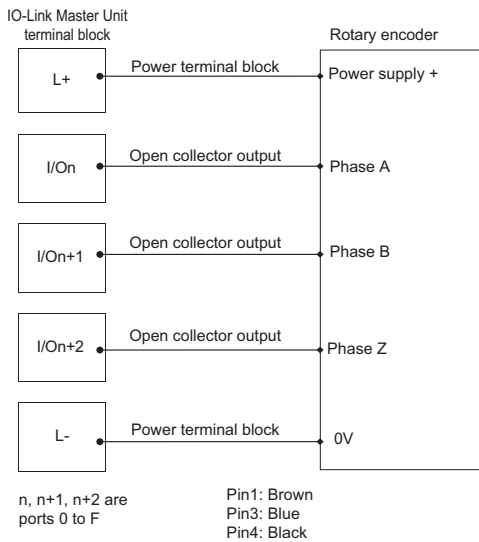

Wire Installation

A single or stranded wire can be used, and a ferrule can be attached to the tip of the wire. The stripped length of single or stranded wire should be 10 mm.

● Wire to be Used

Use wires with diameter and length that are compatible with the terminal block.

- Power terminal block: +24 V, 0 V, L+, L-, FG
AWG 24 to 16
Use wires with a temperature rating of 75°C or higher.
- Device terminal block: L+, I/O, L- (for GD-ILM16C-CLI)
AWG 28 to 16
Use wires with a temperature rating of 75°C or higher.
- Cable length
Maximum 30 m: between power supply and IO-Link Master Unit
Maximum 20 m: between IO-Link Master Unit and IO-Link Device

● Recommended Ferrule and Crimping Tool

- Ferrule for the power terminal block
The recommended ferrule is AI 0.5-10 WH (AWG20) from PHOENIX CONTACT.
For dimensions and ferrules other than AWG20, refer to the table below.
- Ferrule for the Device terminal block
The recommended ferrule is AI 0.25-8 YE (AWG24) from PHOENIX CONTACT.
For dimensions and ferrules other than AWG20, refer to the table below.
- Crimping tool
The recommended crimping tool is CRIMPFOX 6 from PHOENIX CONTACT.
When using a crimping tool other than the recommended one, use a type that crimps from the top and bottom (2 directions). If other tools are used to crimp and insert the terminal block, the terminal block may be damaged when pulling it out.

Unit: mm

Terminal block	AWG	Ferrules from PHOENIX CONTACT							
		Model	Dimensions						Insulation sleeve color
			L1	L2	D1	S1	D2	S2	
Device terminal block For GD-ILM16C-CLI	24	AI 0.25-8 YE	12.50	8.00	0.80	0.15	2.00	0.25	Yellow
	22	AI 0.34-10 TQ	14.50	10.00	0.80	0.15	2.00	0.25	Turquoise
	20	AI 0.5-10 WH	16.00	10.00	1.10	0.15	2.50	0.25	White
	18	AI 1-10 RD	16.00	10.00	1.50	0.15	3.00	0.30	Red
	16	AI 1.5-10 BK	16.50	10.00	1.80	0.15	3.40	0.30	Black
Power terminal block	24	AI 0.25-8 YE	12.50	8.00	0.80	0.15	2.00	0.25	Yellow
	22	AI 0.34-10 TQ	14.50	10.00	0.80	0.15	2.00	0.25	Turquoise
	20	AI 0.5-10 WH	16.00	10.00	1.10	0.15	2.50	0.25	White
	18	A 1-8	-	8.00	1.40	0.15	-	-	Without insulation sleeve
	16	A 1.5-10	-	10.00	1.70	0.15	-	-	Without insulation sleeve

Note The contents of ferrules are as of February 2026.

● Wire Installation Method

- 1 Press the open/close key (orange) of the wire insertion port for installation with a precision flat-head screwdriver.

- 2** Insert the wire from the wire insertion port while pressing the open/close key. Insert the wire until the tip reaches the bottom.
- 3** Release the open/close key to complete wiring. Pull gently to make sure it does not come loose.

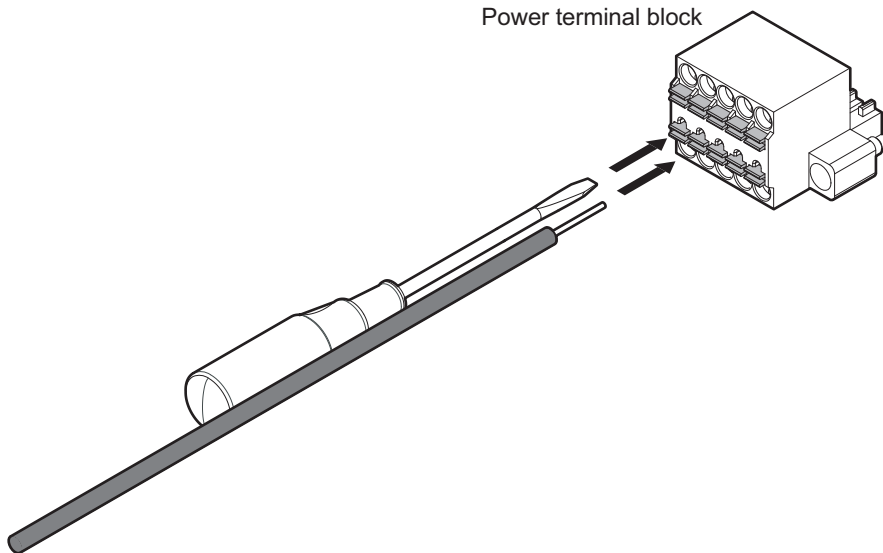

Note For device terminal blocks, insert in the same way.

● Wire With Ferrule Installation Method

- 1** Insert the wire with the ferrule attached through the wire insertion port. Insert the ferrule until the tip of the ferrule reaches the bottom. (In the case of ferrule, it can be inserted without pressing the open/close key.)
- 2** Insert it until it reaches the bottom and the wiring is complete. Pull gently to make sure it does not come loose.

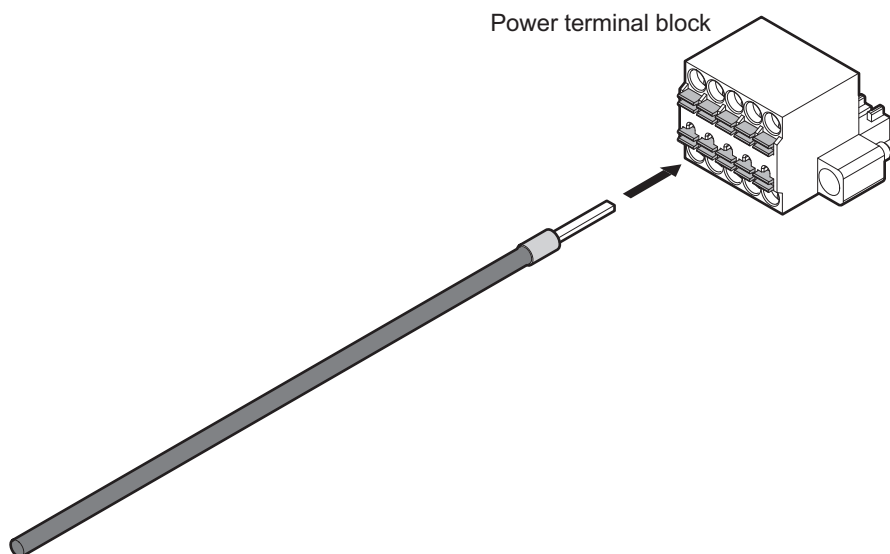

Note For device terminal blocks, insert in the same way.

● Wire Insertion Slot Shape

Before inserting a wire or ferrule, check the shape of the wire insertion port below and the diameter and orientation of the wire or ferrule.

Inserting a wire or ferrule larger than the wire insertion port shown below may damage the terminal block.

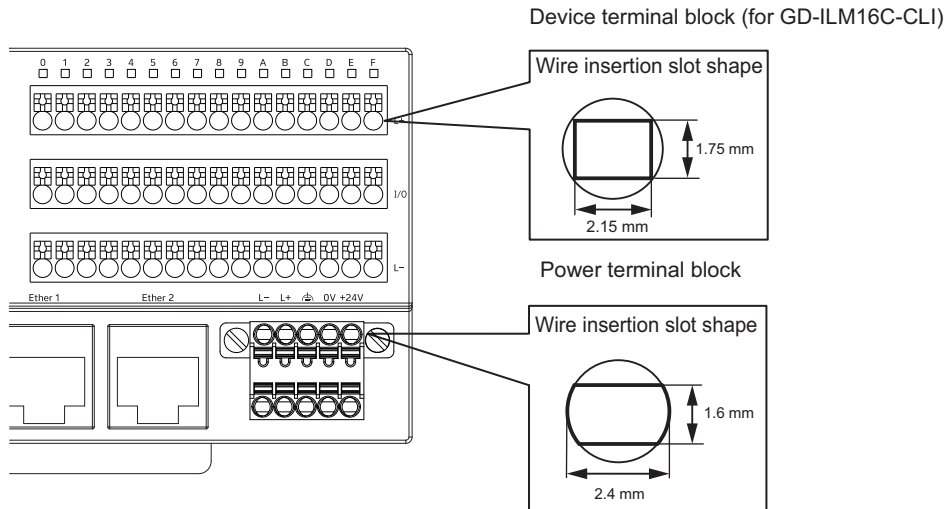

Wire Removal

- 1 Press the open/close key (orange) of the wire insertion port to be removed with a precision flat-head screwdriver.
- 2 Pull out the wire while holding down the open/close key.

Note If the ferrule is stuck inside the terminal block and cannot be removed, the terminal block may be damaged by forceful removal. If the ferrule is stuck, move the ferrule up, down, left, or right while pressing in the open/close key to remove the stuck part, and then pull it out.

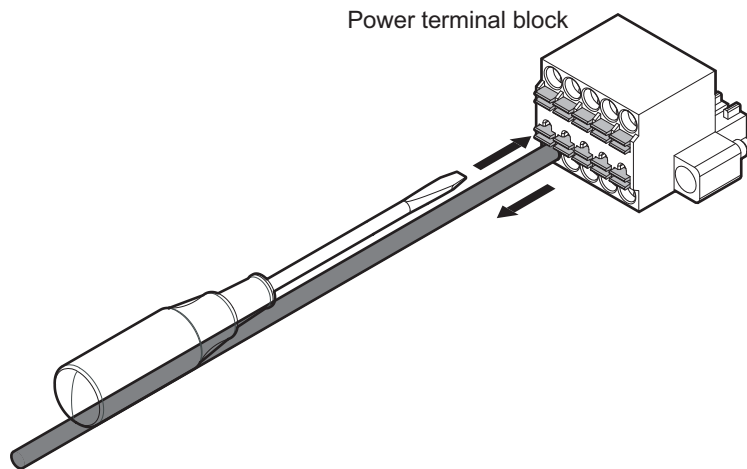

Note For device terminal blocks, pull out in the same way.

2-4 Initial Settings for Front Panel Controls

2-4-1 Powering up the CC-Link IE Field/TSN Master Station

First, apply power to the CC-Link IE Field/TSN master station.

This makes it possible to check whether the CC-Link IE Field/TSN host master station is connected correctly.

2-4-2 Language

When you turn on the power for the first time, the following *M5. Language* window is displayed on the upper left display of this product.

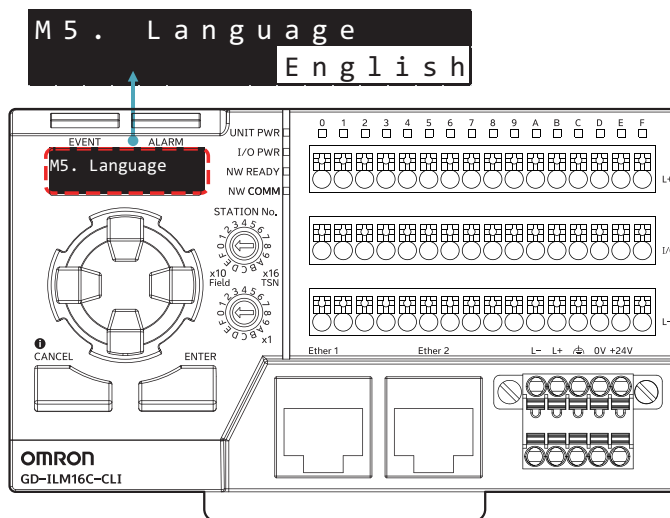

Note The above figure is for GD-ILM16C-CLI. The same applies to GD-ILM16E-CLI.

The language displayed will change each time you press the ↑ button.



Additional Information

If the display is different from the above, press and hold the **CANCEL** button for 3 seconds, then press the ↓ button, then the **ENTER** button, and then press the ↑ button eight times. Select *Master Unit parameters reset* and click the **ENTER** button. After that, press the ↑ button eight times, and then press the **ENTER** button.

Press the **ENTER** button.

The language setting changes to a language you prefer. For CC-Link IE Field, the network number automatic search function will also start (the network number automatic search function is not started for CC-Link IE TSN).



- If the CC-Link IE Field master station is connected properly and the setting are correct, the network number of the connected master station will be displayed after about 5 seconds.
- If the CC-Link IE Field master station is not connected correctly or configured incorrectly, or if a CC-Link IE TSN master station is connected, a timeout will occur after about 15 seconds.

2-4-3 I/O Assignment Settings

Continuing on, the window automatically switches to the screen for changing the I/O functions of all ports as shown below.

```
M 9 . I / O b a t c h s e
N o
```

Pressing the ↑ button will scroll through *IO-Link* → *pnp Input* → *nnp Input* → *PNP Output* → *NPN Output* → *Unused* options in order.



Additional Information

- The channels to be changed can be changed efficiently by selecting the functions you use most in this batch change and reconfiguring them individually (according to *M10. I/O setting*).
- I/O function assignment can also be set from the network configuration settings of GXWorks2/3 (according to parameter processing 5. *Write parameters for I/O and process data*). Refer to 3-2-6 *Executing Parameter Processing to This Product from GXWorks2/3* on page 3-13 for further information.

To batch change all, select the function to be set with the ↑ or ↓ button and press the **ENTER** button.

```
M 9 . I / O b a t c h s e
I O - l i n k
```

Click the **No** or **CANCEL** button to return without changing the settings.

```
M 9 . I / O b a t c h s e
N o
```

To set the I/O function for each port, click the ↓ button to display *M10. I/O setting*.

```
M 1 0 . I / O s e t t i n g
I O - l i n k
```

To switch ports, press the ← or → buttons.

Port number

```
( 1 ) I / O s e t t i n g
I O - l i n k
```

To change the I/O settings, press the **ENTER** button. The setting value can be changed when it flashes. Press the ↑ or ↓ buttons to select the value to set. Press the **ENTER** button to confirm the set value.

If using CC-Link IE TSN, turn OFF the power to the unit and then turn it ON again while holding the **ENTER** button. About 15 seconds after startup, it will automatically switch to CC-Link IE TSN and restart. Alternatively, select *CC-Link IE TSN* in *M2. Network type*.

Refer to *5-1 Front Panel Controls* on page 5-2 for further information.

The following process data display will be the start window if turning the power ON after selecting the language.

Port number



(0)	9	8	7	6	5	4	3	2	1	0	
								1	2	3	%

Refer to *5-1 Front Panel Controls* on page 5-2 for further information about front panel operation.

3

Communication

This section describes the initial settings for CC-Link IE Field/TSN communication and IO-Link communication, the configuration of the data to be handled, and communication examples.

3-1	Communication System Overview	3-2
3-2	Initial Setting of This Product via Software	3-3
3-2-1	Required Software.....	3-3
3-2-2	Procedure Overview	3-3
3-2-3	Reading the CSP+ File for This Product into GXWorks2/3	3-3
3-2-4	Registering This Product to CC IE Field Configurations or CC-Link IE TSN Configurations	3-8
3-2-5	Writing Settings to the CC-Link IE Field/TSN Master Station.....	3-11
3-2-6	Executing Parameter Processing to This Product from GXWorks2/3	3-13
3-2-7	Parameter Processing List from GXWorks2/3 to This Product	3-16
3-2-8	Error Code List when Executing Parameter Processing from GXWorks2/3..	3-17
3-3	Setting Product Master Unit Parameters	3-19
3-3-1	Setting via GXWorks2/3	3-19
3-3-2	Setting via Front Panel Controls.....	3-19
3-3-3	Setting via Host Master Station Communication Instructions.....	3-19
3-4	CC-Link IE Field/TSN Communication and IO-Link Communication with This Product.....	3-20
3-4-1	Cyclic Communication (Cyclic Transmission/Process I/O Communication)..	3-20
3-4-2	Acyclic Communication (Transient Transmission/ISDU Communication)	3-31
3-4-3	Event Communication	3-37
3-5	Parameter Setting/Monitoring Inside IO-Link Devices	3-38
3-5-1	Reading/Writing IO-Link Device Data via Host Master Station Communication Instructions.....	3-38
3-5-2	Parameter Settings inside IO-Link Devices Connected to This Product, via Product Front Panel Operation	3-38
3-6	Specific Communication Examples (Including Sample Programs)	3-39
3-6-1	Example of Cyclic Communication	3-39
3-6-2	Example of Acyclic Communication	3-41

3-1 Communication System Overview

This product performs IO-Link cyclic communication with the connected IO-Link devices. It collects data from these IO-Link devices and, along with its own status, conveys them through CC-Link IE cyclic communication with the CC-Link IE Field/TSN master station.

As well, the product can perform acyclic communication with its own and various connected IO-Link device objects from CC-Link IE Field/TSN master station communication instructions or GXWorks2/3.

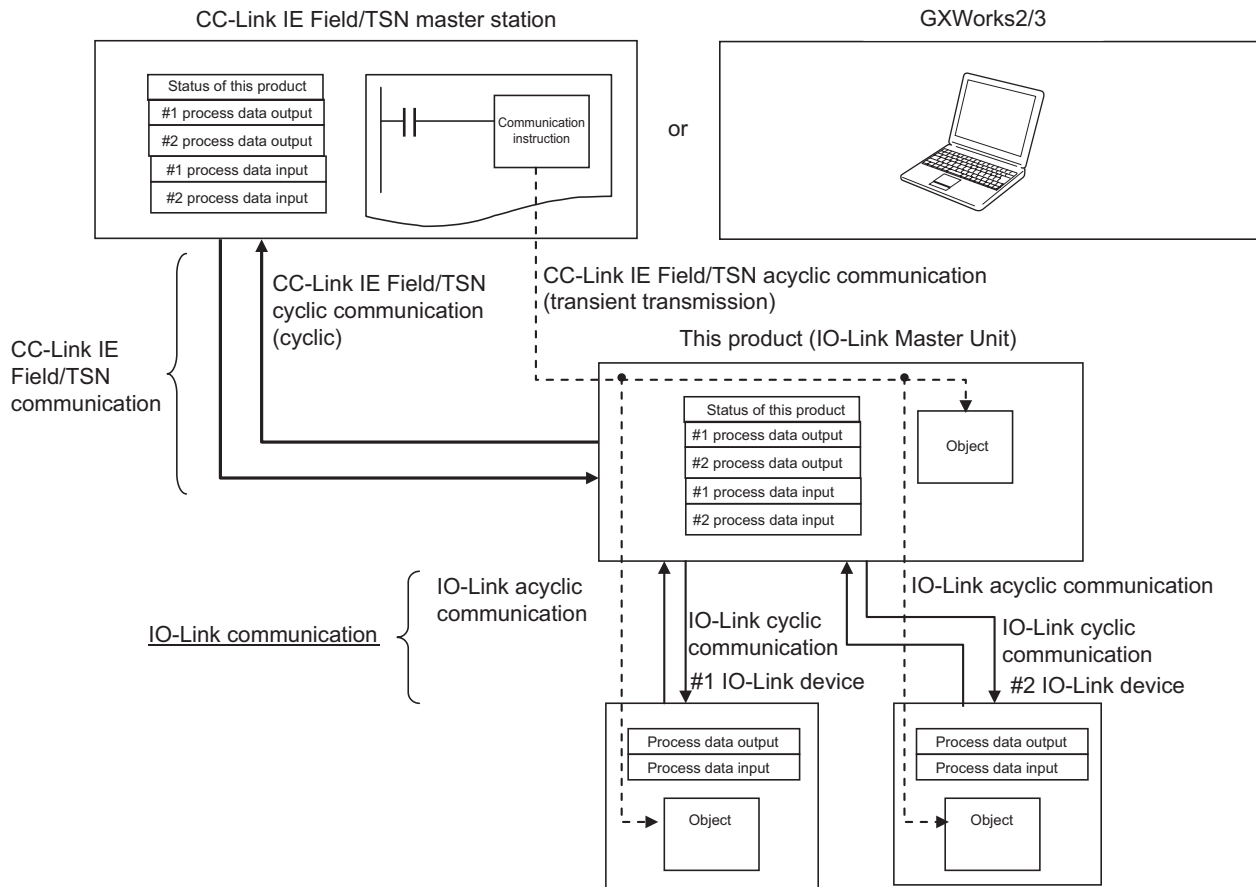

3-2 Initial Setting of This Product via Software

Create initial settings for the product with software such as GXWorks2/3.

Note The procedures described below reference screen captures from GX Works2 or GX Works3, with red frames, arrows, and other annotations added to the referenced images for illustrative purposes.

3-2-1 Required Software

- Engineering tool for CC-Link IE Field/TSN:
GXWorks2 or GXWorks3 (tool used as the products CC-Link IE Field/TSN slave)

3-2-2 Procedure Overview

- 1 Download the CSP+ file for this product from the OMRON website.
- 2 Register the CSP+ file for this product profile in GXWorks2/3.
- 3 In GXWorks2/3, register the product to CC IE Field or CC-Link IE TSN configuration.
- 4 Input the settings for CC-Link IE Field/TSN communication between this product as the slave station and the CC-Link IE Field/TSN master station (station number and input allocation (*1)), and write to the CC-Link IE Field/TSN master station.

*1. Allocate this product's remote I/O signals to the remote input (RX) and remote output (RY) of the upper CC-Link IE Field/TSN master station.

3-2-3 Reading the CSP+ File for This Product into GXWorks2/3

- 1 Download the CSP+ file for this product from the OMRON website below.
<http://www.fa.omron.co.jp/>
The following two types of CSP+ files are used, depending on the upper network type.
Download one or the other.

Upper network types	CSP+ file
CC-Link IE Field communication:	0x1109_GD-ILM16C-CLI(IEF)_1_en
CC-Link IE TSN communication:	0x1109_GD-ILM16C-CLI(TSN)_1_en

- 2 Register the above CSP+ file for this product in GXWorks2/3.
 - 1) Launch GXWorks2/3 (GXWorks2 or GXWorks3).
 - 2) From **Profile Management** in the **Tool** menu, select **Register**.

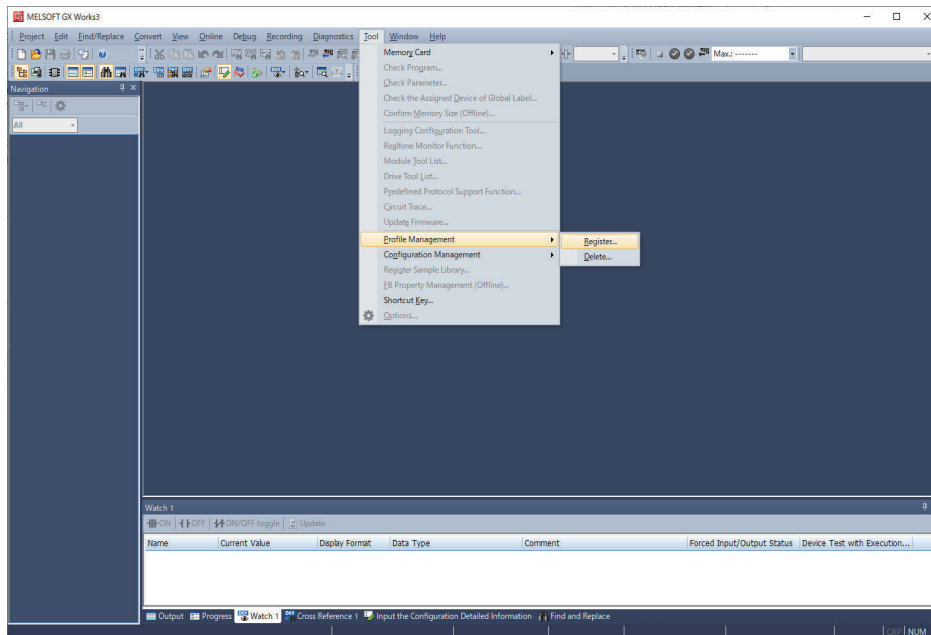

- 3 Select the CSP+ file prepared in advance and click the **Register** button.

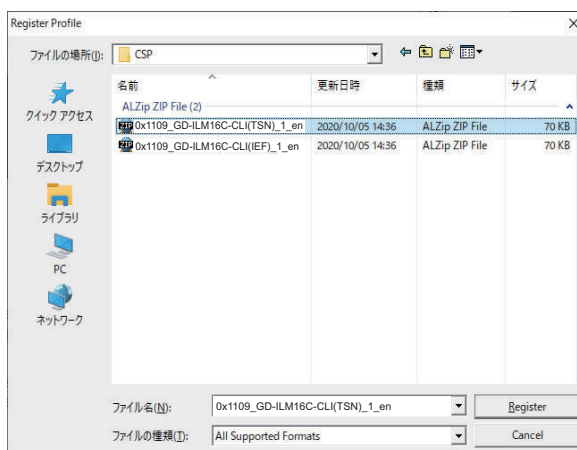

The file is compressed in .zip format and can be registered without unzipping.

Multiple files can also be selected for simultaneous registration by pressing the **Ctrl** and **Shift** keys.

When registration completes normally, the following dialog box will be displayed.

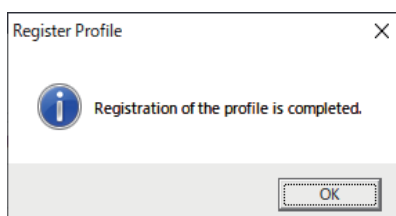

- 4 Click the **OK** button and close the window.

This completes the CSP+ file reading.

Note Which of CC-Link IE Field and CC-Link IE TSN to use as the upper network is set with *Network type* in the Master Unit parameters (M2 with front panel operation) (default value is CC-Link IE Field).

- 5 Continuing, create a new project or open an existing one in GXWorks2/3. Select **New** in the **Project** menu.

If possible, connect the PLC CPU module and computer with a USB cable and turn on the power.

As well, set the *M3 Network No* for this product to 1, the first digit of the station number rotary switch to 0 and the second digit to 1, connect to the CC-Link IE Field/TSN Master Unit with an Ethernet cable, and turn on the power.

Select the *Series*, *Type*, and *Program Language* to use for the CPU module and click the **OK** button.

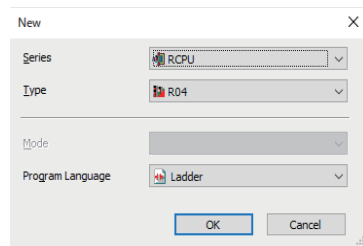

The following dialog box is displayed to confirm the addition of the CPU module (depending on the configuration, the addition may complete automatically without showing the dialog box).

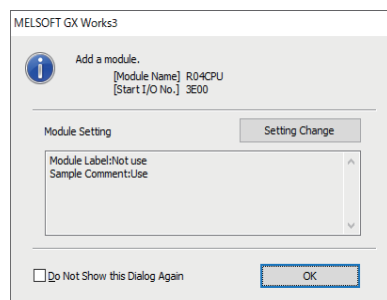

Add the connected CC-Link IE Field/TSN Master Unit.

Click the **+** mark by **Parameter** in the navigation window to open it, right-click on **Module Information**, and select **Add New Module** from the pop-up menu.

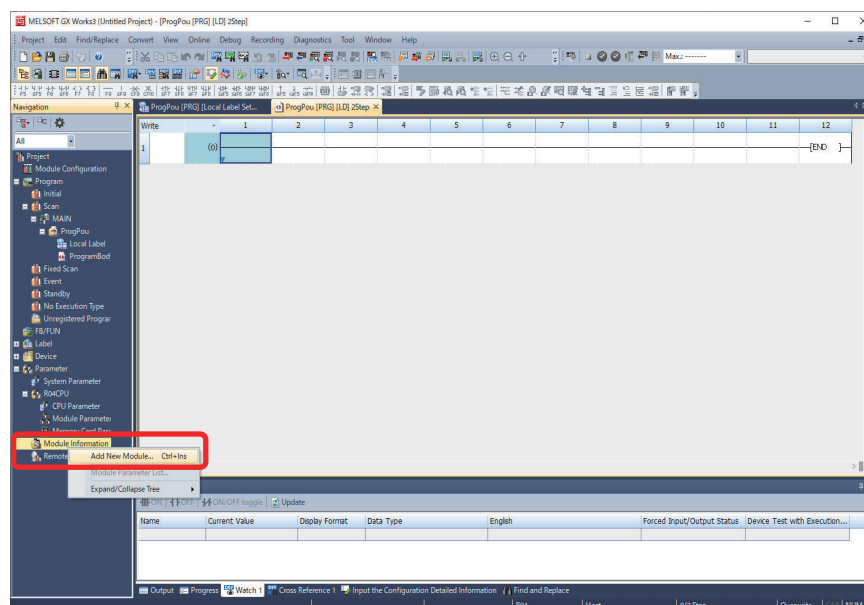

Select *Network Module* from **Module Type**, select the model connected from **Module Name**, and select *Master Station* from **Station Type**.

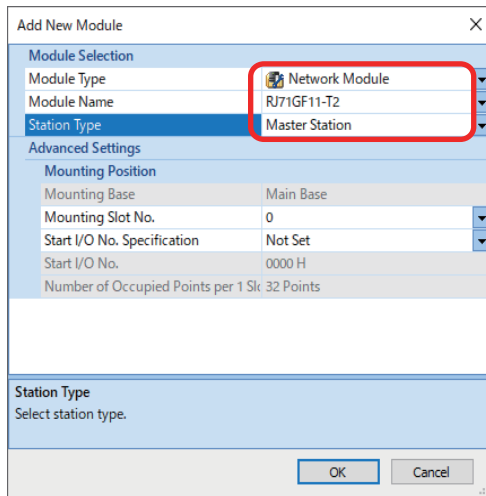

Carry out a parameter check as prompted.

Select **Check Parameter** from the **Tool** menu.

Set the CC-Link IE Field/TSN Master Unit parameters.

From the module information under parameter in the navigation tree, double-click on the model of the CC-Link IE Field/TSN Master Unit.

Note that for CC-Link IE Field, this *Network No.* must be the same value as the product's set value *M3 Network No.*

From the **Setting Item List**, click *Basic Settings*.

In **Refresh Settings** in **Setting Item** at right, double-click *Detailed Setting*.

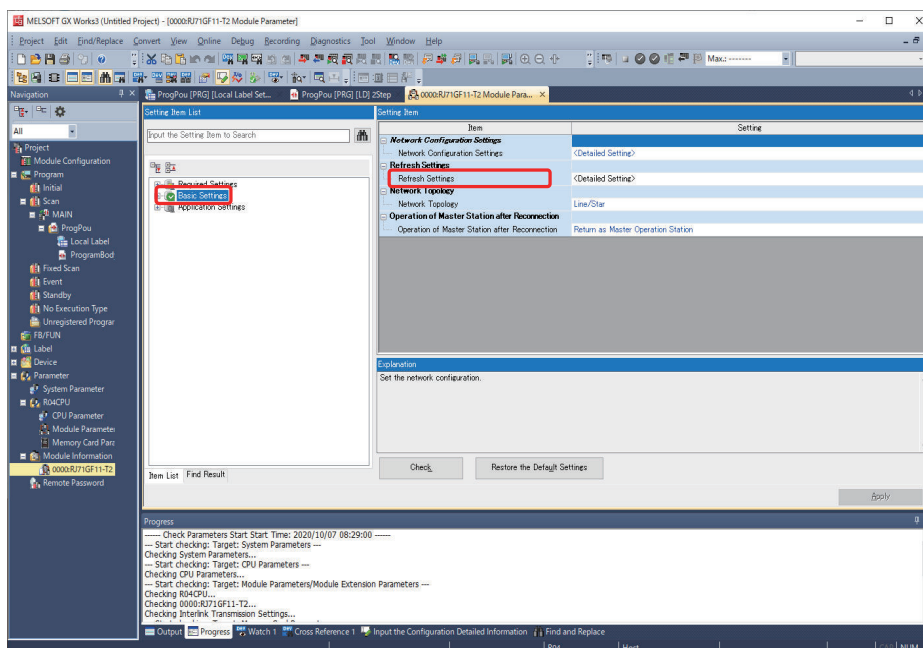

Here, set which CPU module device the data handled by the CC-Link IE Field/TSN Master Unit will be transferred to.

This product uses 32 I/O points I/O each bit devices and 32 points I/O each word devices per unit.

Example of Refresh settings

Link Side					CPU Side				
Device Name	Points	Start	End		Target	Device Name	Points	Start	End
RX	32	00000	001F	↔	Specified Device	X	32	01000	0101F
RY	32	00000	001F	↔	Specified Device	Y	32	01000	0101F
RWr	32	00000	001F	↔	Specified Device	D	32	1000	1031
RWw	32	00000	001F	↔	Specified Device	D	32	1100	1131

Including other connected devices, decide how much transfer volume is required and which device to transfer to.

In this example, there is just one unit connected to the product, showing the minimum transfer. Also, the range settings for SB (link special relay) and SW (link special register) may remain blank in this example.

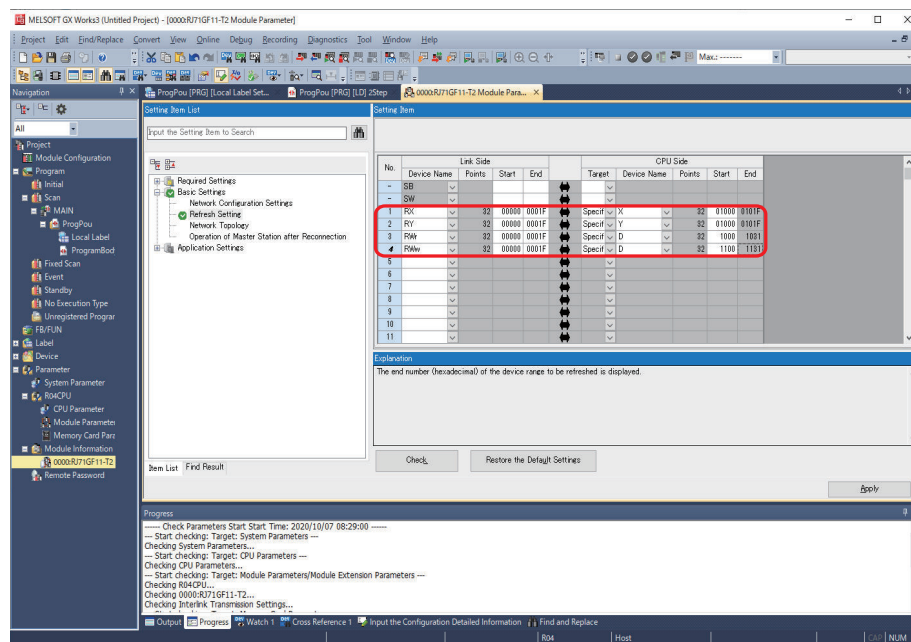

Click the **Check** button and confirm any errors.

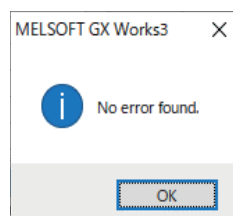

If there are no errors, click the **Apply** button.

Once again click **Basic Settings**.

Network Configuration Settings is shown at right, so double-click *Detailed Setting*.

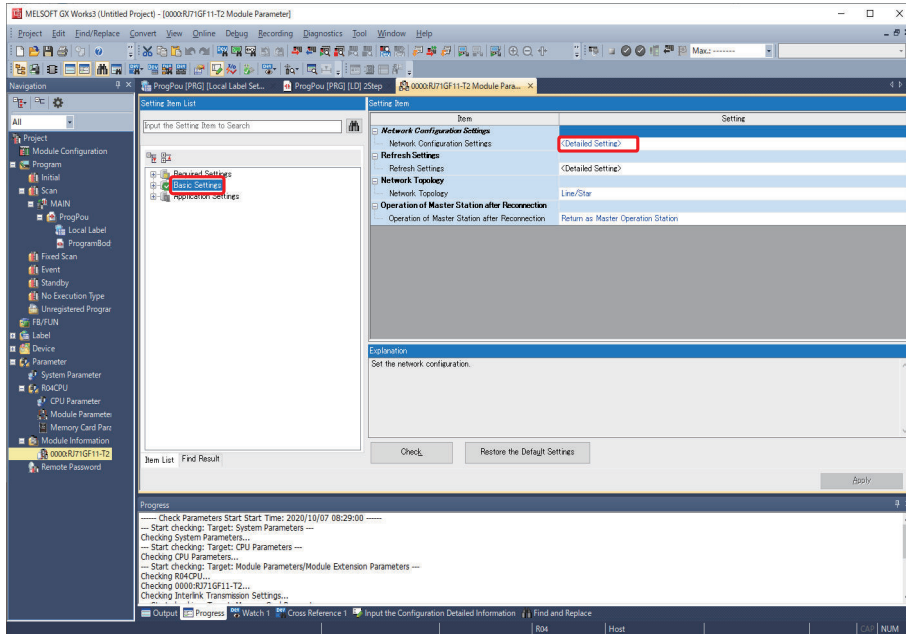

A dialog box checking whether or not to save the parameters set in slave station parameter processing to the project is displayed.

Click the **No** button here. (You may also click the **Yes** button without issue.)

The CC-Link IE Field or CC-Link IE TSN configuration window is displayed.

(Also, at this point the CPU module and CC-Link IE Field Master Unit or CC-Link IE TSN unit are not written into the parameters, so automatic detection of connected devices cannot be performed.)

3-2-4 Registering This Product to CC IE Field Configurations or CC-Link IE TSN Configurations

In GXWorks2/3, register the product to CC IE Field or CC-Link IE TSN configuration.

Registering the Product Offline to CC IE Field or CC-Link IE TSN Configuration

Scroll down the list of modules on the right to display *CC-Link IE Field Module* or *CC-Link IE TSN Module*.

Open this to display *GD-ILM16C-CLI (IEF)* or *GD-ILM16C-CLI (TSN)* under *IO-Link Master I/O Unit*. The profile version can be confirmed with this date.

Drag and drop *GD-ILM16C-CLI (IEF)* or *GD-ILM16C-CLI(TSN)* into the network map at left.

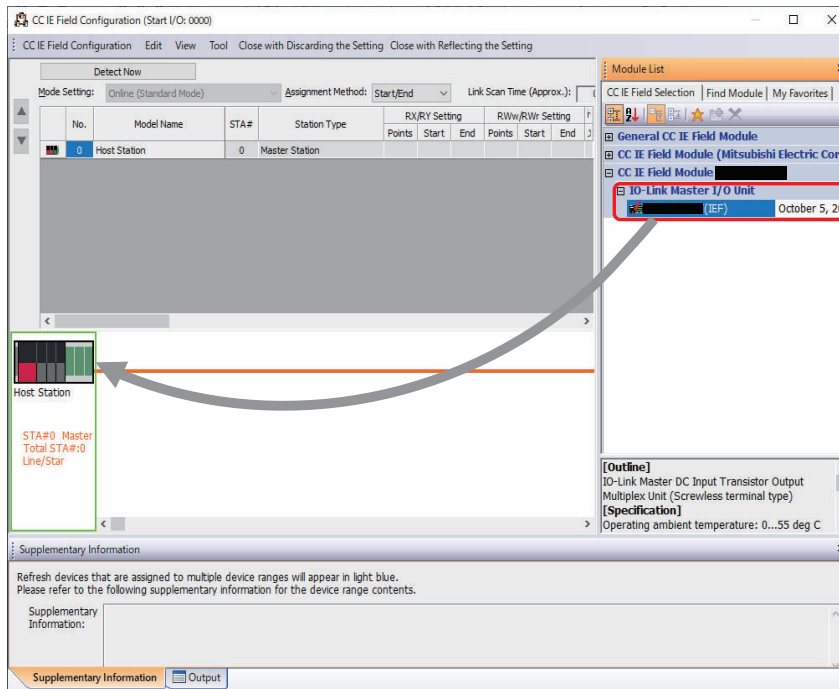

This product will be added to the network map.



Additional Information

The dragged and dropped modules will also be displayed in the list of stations at top.

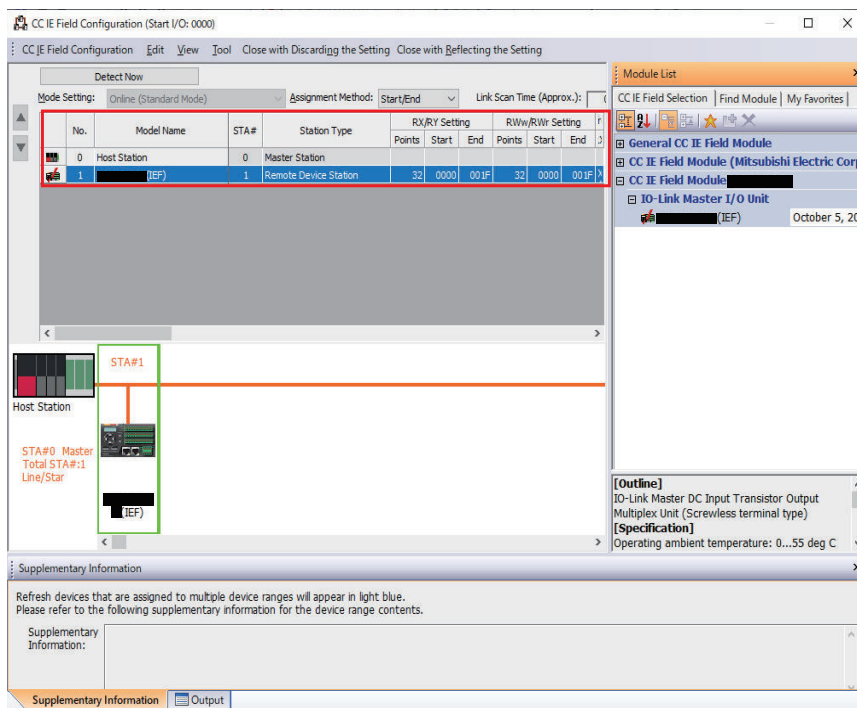

In the list of stations displayed at top, set the product's station I/O number and allocate the link devices (RX, RY, RWr, RWw) to the product.

Setting Items	Setting Details
Station number	Set the station number for the CC-Link IE slave station to be connected to the CC-Link IE network. Note Numbers do not need to be consecutive (but must not be repeated).
Station type	<i>Remote device station</i> (set automatically)
RX/Ry setting	Set the following allocations for RX and RY. Points *1, Start, End
RWw/RWr setting	Set the following allocations for RWw and RWr. Points *1, Start, End

*1. 32 points (bits) each are set automatically.

Click **Close with Reflecting the Setting** and return to the Basic Setting window below.

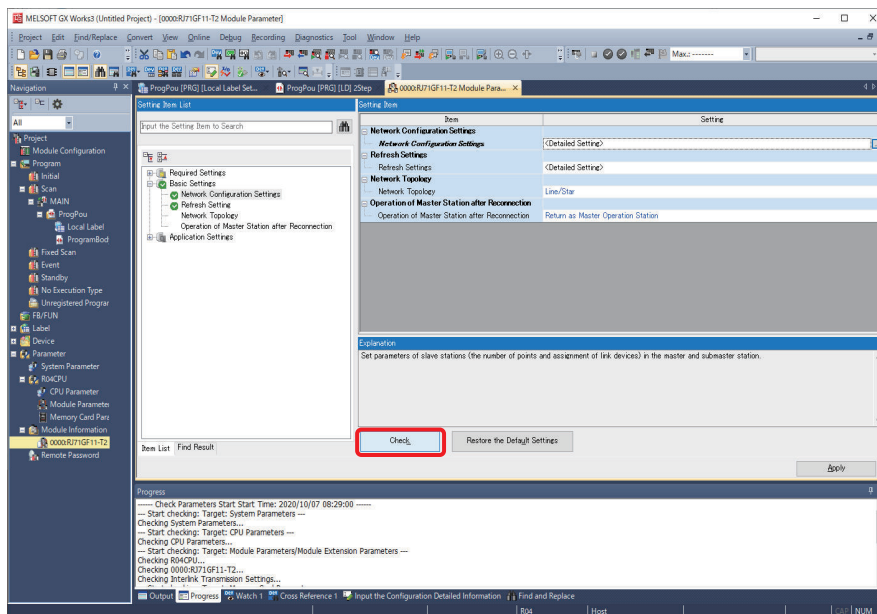

Click the **Check** button.

If there is no problem, the following dialog box will be displayed.

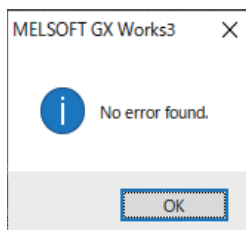

Click the **OK** button. The window below will return.

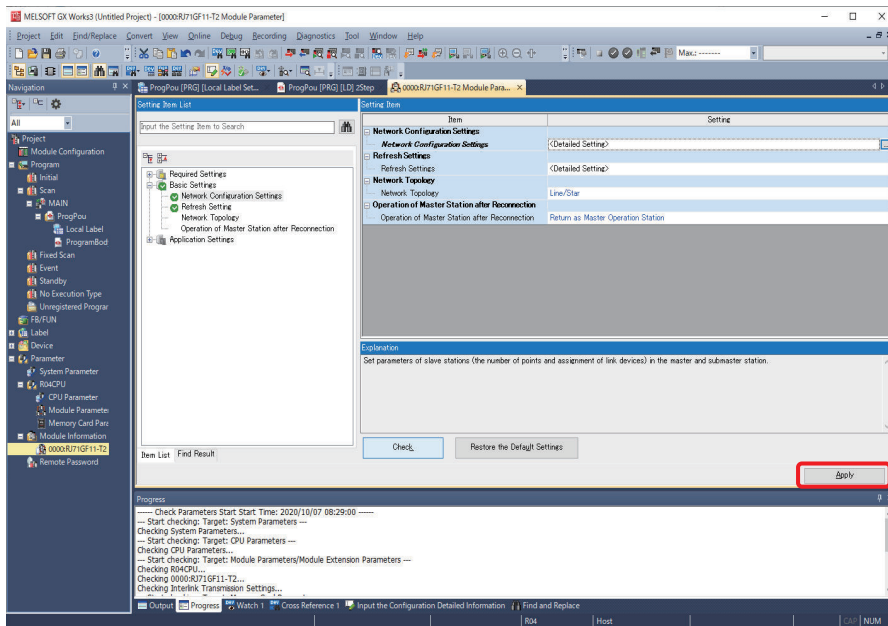

Click the **Apply** button.

At this point, the necessary information for CC-Link IE network communication has all been input.

However, here the settings have been made only on the computer, and the setting details also need to be written to the CC-Link IE Field/TSN master station.

3-2-5 Writing Settings to the CC-Link IE Field/TSN Master Station

Online, write the setting details required for CC-Link IE Field/TSN to the CC-Link IE Field/TSN master station.

From the **Online** menu, select **Write to PLC**.

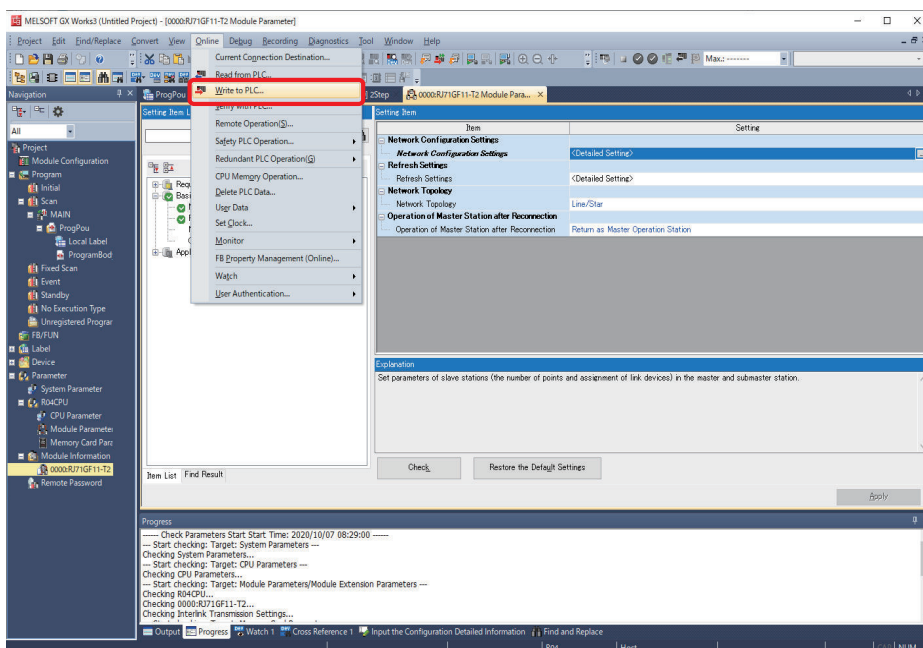

Select the parameter to write.

As this is the first time, click the **Untitled Project** checkbox.

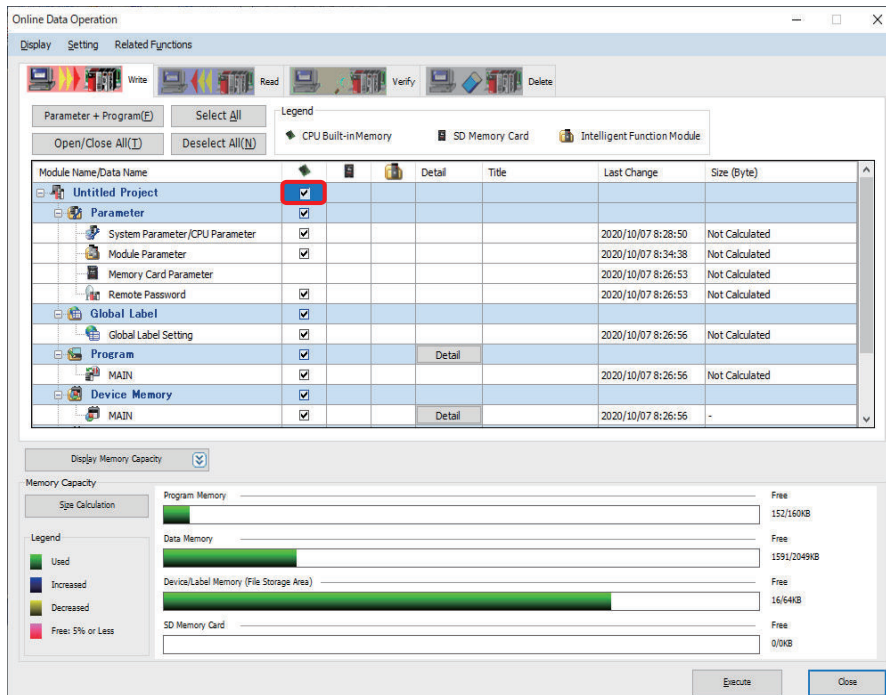

Click the **Execute** button to display the confirmation dialog box for continued writing to the PLC. Click the **Yes** button. The confirmation dialog box for execution of writing to the PLC after remote stop will be displayed.

Click the **Yes** button. The following confirmation dialog box will be displayed.

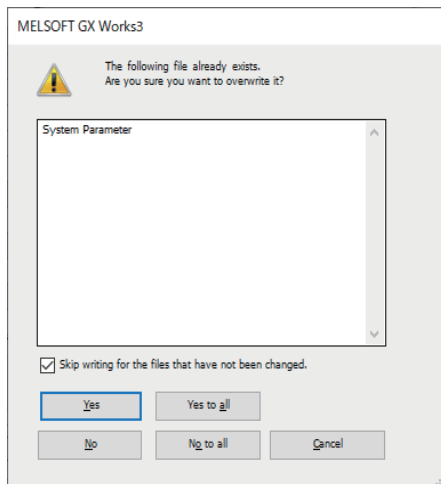

Click the **Yes to all** button to begin writing. When complete, the following dialog box will be displayed.

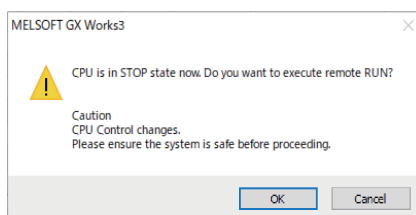

Here the CC-Link IE settings are complete on the CC-Link IE Field/TSN master station side.

Here, reset the host master station side CPU module.

Confirm that the CPU module restarts, the CPU module and CC-Link IE Field/TSN Master Unit ERR LEDs go off, and CC-Link IE Field/TSN communication has been established.



Additional Information

- When writing setting details to the CC-Link IE Field/TSN master station, it must be reset.
- If the product front panel NW COMM LED does not light up blue-green (showing normal communication) even after setting is complete, once again check the GXWorks2/3 settings and product settings.

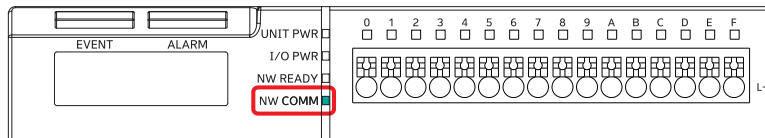

- If communication is not possible even after all the confirmation above, refer to the manuals for each CC-Link IE Field/TSN master station.

3-2-6 Executing Parameter Processing to This Product from GXWorks2/3

- 1 Double-click *Detailed Setting* under **Network Configuration Settings** in the CC-Link IE Field/TSN Master Unit **Basic Settings**.

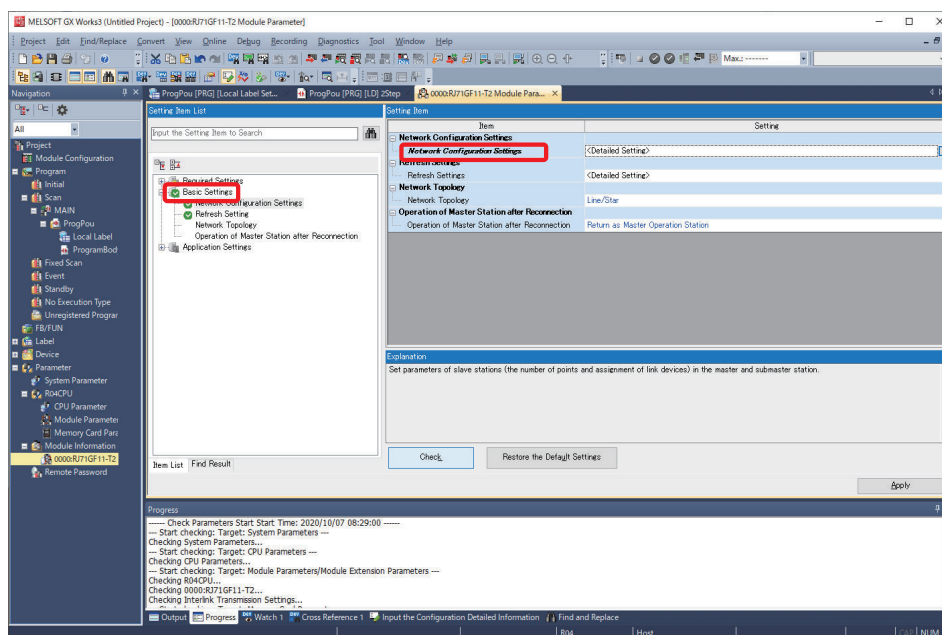

- 2 In the CC IE Field or CC-Link IE TSN Configuration window, select this product in the device map area and select **Online --> Parameter Processing of Slave Station**.

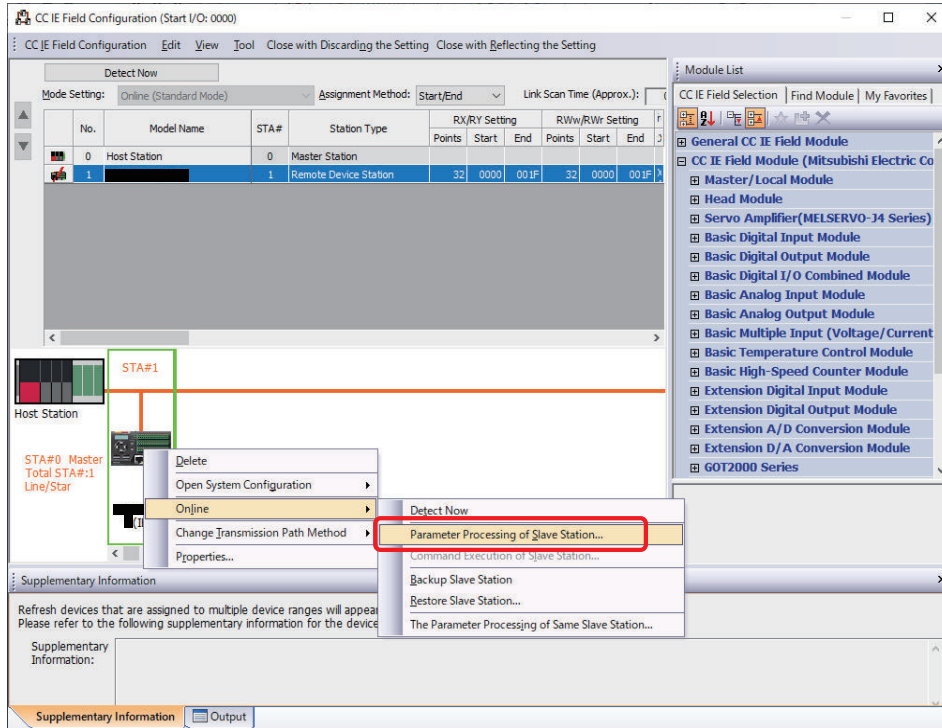

The **Parameter Processing of Slave Station** window will open.

3 In Method selection, select the function to be set.

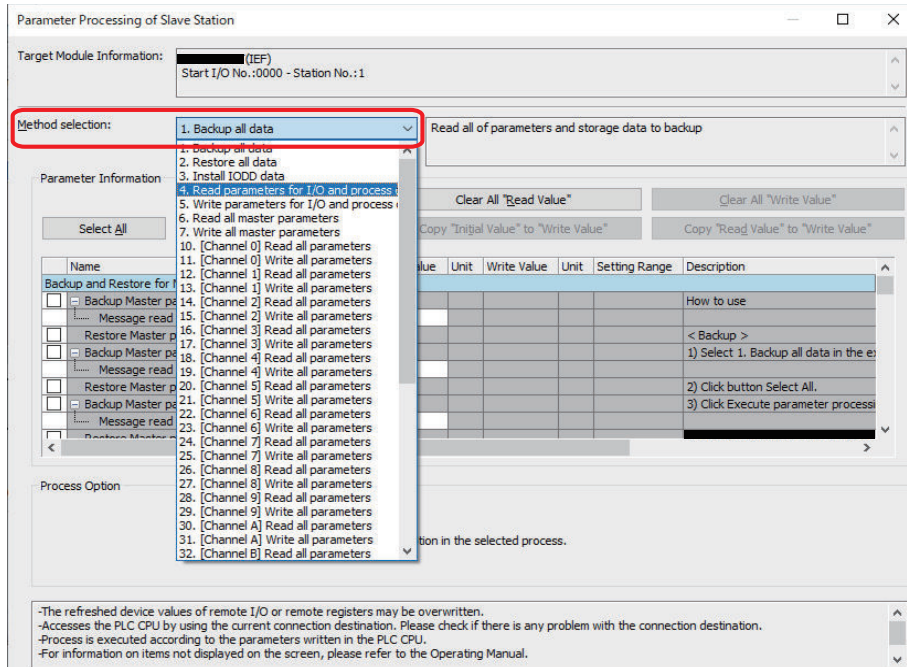

For example, to set the product's I/O assignment, select 5. *Write parameters for I/O and process data.*

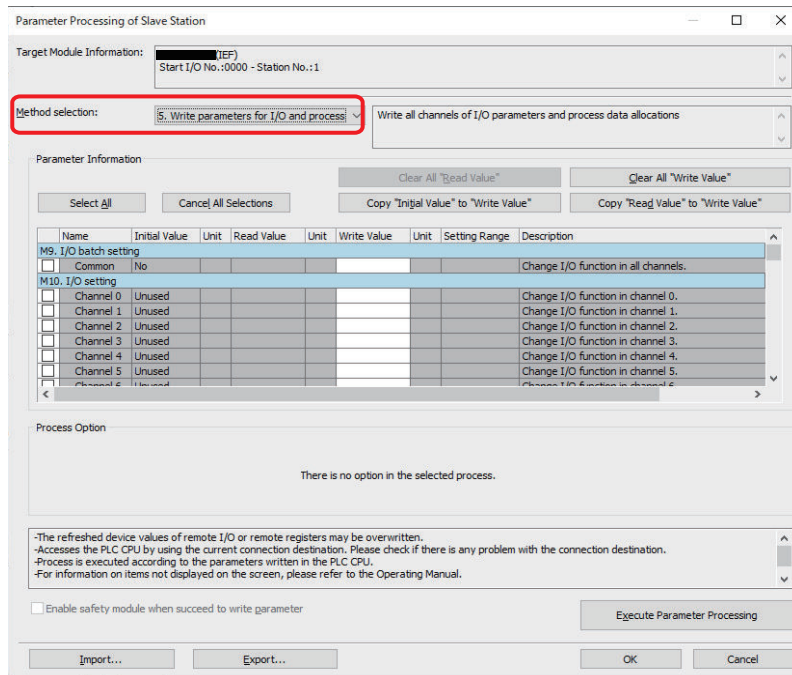

To set all ports alike, set the write value to *M9. I/O batch setting* and click the checkbox at left. To set separately, set the write value to *M10. I/O setting* and click the checkbox at left. Regarding executable processing, refer to 3-2-7 *Parameter Processing List from GXWorks2/3 to This Product* on page 3-16 below.

- 4 Click the item to be changed and enter the set value.
- 5 After setting the value, click the **Execute Parameter Processing** button below right.

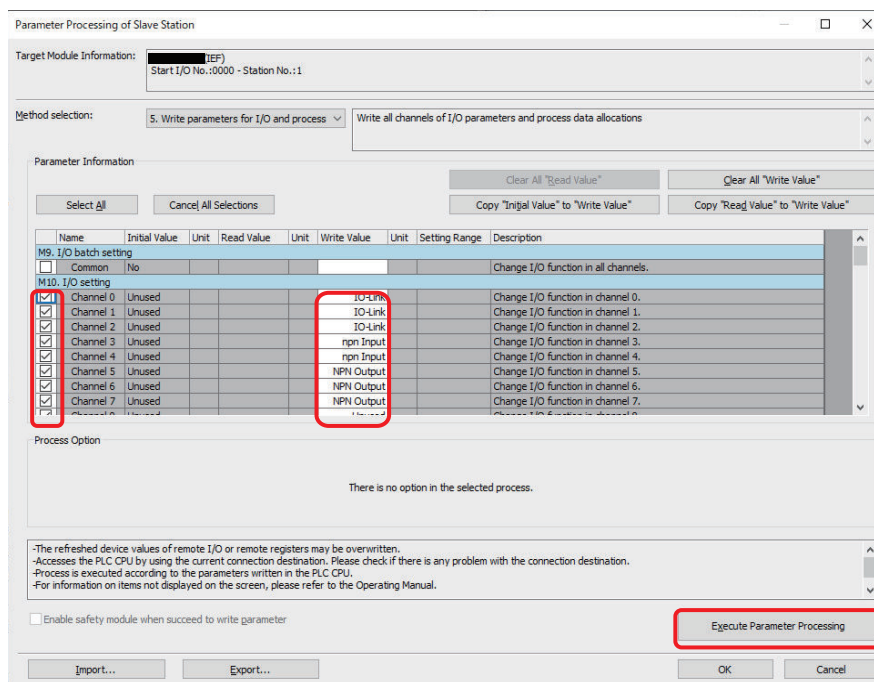

A dialog box confirming execution of the 5. *Write parameters for I/O and process data* process is displayed.

- 6 Click the **Yes** button.
- 7 The parameters are written to the product.
When writing is complete, a dialog box confirming completion of the 5. *Write parameters for I/O and process data* process is displayed.
- 8 Select **Close with Reflecting the Setting** and end Network Configuration Settings.

The set values have been written to the product.
Other required settings can be written in the same way.



Additional Information

- The I/O setting assignment status can be checked on the project front panel window. After selecting the language, in the startup screen process data displayed when turning on the power, press the **ENTER** button for a batch display of the I/O assignment status as below.

```
0123456789ABCDEF
IIInnNNN-----
```

Example:

- I: IO-Link Mode Setting
(If blinking then IO-Link device is not connected.)
- n: NPN Input Mode Setting
- N: NPN Output Mode Setting
- : Not used

Refer to *Section 5 Front Panel Controls* on page 5-1 for details on front operation.

- To read out parameters from the product, set **Method selection** in 4. *Read parameters for I/O and process data* and click the **Execute Parameter Processing** button.
- Set all items for the checked parameters. If anything is left blank, the parameters cannot be written to the product.

3-2-7 Parameter Processing List from GXWorks2/3 to This Product

The list of parameter processing functions to the product from GXWorks2/3 is displayed as below.

Function	Description
1. Backup all data	Batch reads the Master Unit parameters and storage data.
2. Restore all data	Batch writes the Master Unit parameters and storage data.
4. Read parameters for I/O and process data	Reads out parameter values for all ports' I/O functions and process data assignment.
5. Write parameters for I/O and process data	Writes parameter values for all ports' I/O functions and process data assignment.
6. List of set value readouts for Master Unit.	List of set value readouts for Master Unit.
7. List of set value writing for Master Unit.	List of set value writing for Master Unit.
10. [Port 0] Read all parameters	List of set value readouts for port 0.
11. [Port 0] Write all parameters	List of set value writing for port 0.
12. [Port 1] Read all parameters	List of set value readouts for port 1.
13. [Port 1] Write all parameters	List of set value writing for port 1.
14. [Port 2] Read all parameters	List of set value readouts for port 2.
15. [Port 2] Write all parameters	List of set value writing for port 2.
16. [Port 3] Read all parameters	List of set value readouts for port 3.
17. [Port 3] Write all parameters	List of set value writing for port 3.

Function	Description
18. [Port 4] Read all parameters	List of set value readouts for port 4.
19. [Port 4] Write all parameters	List of set value writing for port 4.
20. [Port 5] Read all parameters	List of set value readouts for port 5.
21. [Port 5] Write all parameters	List of set value writing for port 5.
22. [Port 6] Read all parameters	List of set value readouts for port 6.
23. [Port 6] Write all parameters	List of set value writing for port 6.
24. [Port 7] Read all parameters	List of set value readouts for port 7.
25. [Port 7] Write all parameters	List of set value writing for port 7.
26. [Port 8] Read all parameters	List of set value readouts for port 8.
27. [Port 8] Write all parameters	List of set value writing for port 8.
28. [Port 9] Read all parameters	List of set value readouts for port 9.
29. [Port 9] Write all parameters	List of set value writing for port 9.
30. [Port A] Read all parameters	List of set value readouts for port A.
31. [Port A] Write all parameters	List of set value writing for port A.
32. [Port B] Read all parameters	List of set value readouts for port B.
33. [Port B] Write all parameters	List of set value writing for port B.
34. [Port C] Read all parameters	List of set value readouts for port C.
35. [Port C] Write all parameters	List of set value writing for port C.
36. [Port D] Read all parameters	List of set value readouts for port D.
37. [Port D] Write all parameters	List of set value writing for port D.
38. [Port E] Read all parameters	List of set value readouts for port E.
39. [Port E] Write all parameters	List of set value writing for port E.
40. [Port F] Read all parameters	List of set value readouts for port F.
41. [Port F] Write all parameters	List of set value writing for port F.
50. Read parameters for input filter and synchronization	Reads out all ports' input filters, error processing, and I/O synchronous operation parameter values.
51. Write parameters for input filter and synchronization	Writes all ports' input filters, error processing, and I/O synchronous operation parameter values.
54. Read parameters for storage	Reads out all ports' IO-Link storage settings.
55. Write parameters for storage	Writes all ports' IO-Link storage settings.
60. Read data from IO-Link device	Reads out all ports' IO-Link device specified index number data, models, and user tag names.
61. Write data to IO-Link device	Writes all ports' IO-Link device specified index number data and user tag names.
70. Read Event and Error	Reads out all ports' IO-Link error and event information.
EX1. Read diagnostic information of master and IO-Link	Reads out the master and all ports' IO-Link communication diagnostic information.
EX2. Clear error and overcurrent counter, Service mode	Clears all ports' IO-Link communication error count.
EX3. Remote control	Remotely operates the master display and buttons.
EX4. Read trace data of IO-Link	Reads out the specified port's IO-Link device communication trace data.
EX5. Start trace of IO-Link	Traces the specified port's IO-Link device communication data.

3-2-8 Error Code List when Executing Parameter Processing from GXWorks2/3

This is the list of error codes during parameter processing to the product from GXWorks2/3.

Screen Example

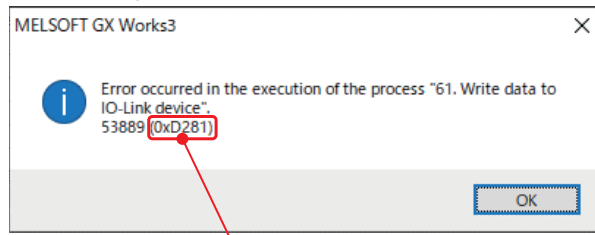

This code.

Error code	Error details
0xD211	A negative response was returned when reading out the specified index number to the IO-Link device.
0xD223	Error when writing the set value to the product.
0xD230	Outside the range of set value writing to the product.
0xD233	The set value data is too long.
0xD234	The read set value data length is 0.
0xD280	Access to the IO-Link device used a port number out of range.
0xD281	IO-Link device writing was executed in a port with no IO-Link device connected.
0xD282	Set value access used an IO-Link device not supporting ISDU.
0xD293	EEPROM overwriting was attempted during test mode (mode for rewriting firmware).
0xD294	The storage target IO-Link device is not connected.

3-3 Setting Product Master Unit Parameters

This section describes how to set product Master Unit parameters.

As shown below, there are three setting methods.

- Setting with front panel controls
- Setting with GXWorks2/3
- Setting with communication instructions from host master station

For the details of product Master Unit parameters, refer to *6-4 List of Product Master Unit Parameters* on page 6-12.

3-3-1 Setting via GXWorks2/3

In CC IE Field (or CC-Link IE TSN) Configuration, select this product and right-click to select **Slave station parameters** in order to display the *Parameter Processing of Slave Station* window.

For the process to be executed, select *7. Write all Master Unit parameters* from the pull-down list and click the **Execute Parameter Processing** button.

Refer to *3-2-6 Executing Parameter Processing to This Product from GXWorks2/3* on page 3-13 and *3-2-7 Parameter Processing List from GXWorks2/3 to This Product* on page 3-16 for further information.

3-3-2 Setting via Front Panel Controls

Refer to *5-1-3 Master Unit Parameters Window* on page 5-5 of *Section 5 Front Panel Controls* on page 5-1 for further information.

3-3-3 Setting via Host Master Station Communication Instructions

This product's Master Unit parameters can be set using the following communication instructions on a Mitsubishi Electric PLC.

- For CC-Link IE Field communication: RIRD instruction (readout), RIWT instruction (write)
Refer to the manuals below for further information on instructions.
For a Q Series PLC: *Mitsubishi Electric MELSEC-Q CC-Link IE Field Network Master/Local Module User's Manual*
For an iQ-R Series PLC: *Mitsubishi Electric MELSEC iQ-R Programming Manual (Module Dedicated Instructions)*
- For CC-Link IE TSN communication: SLMPSND instructions
Refer to the manuals below for further information on instructions.
Mitsubishi Electric MELSEC iQ-R Programming Manual (Module Dedicated Instructions)

3-4 CC-Link IE Field/TSN Communication and IO-Link Communication with This Product

This product supports both cyclic and acyclic communication as a remote device station among the CC-Link IE Field/TSN slave stations.

It also supports both cyclic (process data) and acyclic (ISDU) communication as an IO-Link Master Unit. Further, when the connected IO-Link device sends the product event data, it can store up to six event types and event codes.

3-4-1 Cyclic Communication (Cyclic Transmission/Process I/O Communication)

This product exchanges the following data regularly in CC-Link IE Field/TSN with the CC-Link IE Field/TSN master station link device (RX/Ry/RWr/RWw).

- Digital input/digital output in SIO mode, product status/operation flags: Bit unit
- IO-Link device I/O maximum 32 bytes of process data: Word unit

Normal Assignment and Extended Access Enabled Assignment

The unit can be switched between using either of the following two assignment methods.

- Normal assignment: Assignment method where everything is cyclic data shared type.
- Extended access enabled assignment: This assignment method allows setting values to be accessed without using acyclic communication, for normal cyclic data shared type assignments.

The following can be accessed.

- a) Any service data in any connected IO-Link device
- b) Master Unit parameters of this product

The assignment method (normal assignment or extended access enabled assignment) is specified using *Extended access enable flag* (RY10).

The following is shown when both the *M40. Process input data words allocation* and *M41. Process output data words allocation* Master Unit parameters are the default values.

Normal Assignment (When Extended Access Is Disabled)

● Assignment of Host Master Station Link Devices

This product assigns the *RX*, *RY*, *RWr* and *RWw* of Setting Item in GXWorks2/3 parameter settings **Basic Settings - Network Configuration Settings** from the set start numbers to the host master station link devices.

Link De-vice	Word Address (Start number +)	Bit Address															
		F	E	D	C	B	A	9	8	7	6	5	4	3	2	1	0
RX	0□	Digital input (port 0-F: corresponds to bit address 0-F)															
	1□	Error	IO-Link Ready	Synchronization establishment	Reserved	Latest error port				Event	I/O power supply	Output overcurrent	Reserved	Latest Event port			
RY	0□	Digital output (port 0-F: corresponds to bit address 0-F)															
	1□	Clear the latest error	Error handling switching	Reserved						Clear the latest event	Reset encoder counter	Reserved				Extended access enabled	
RWr	00	Process input data port 0*1															
	01																
	02	Process input data port 1*1															
	03																
															
	1E	Process input data port F*1															
	1F																
RWw	00	Process output data port 0*1															
	01																
	02	Process output data port 1*1															
	03																
															
	1E	Process output data port F*1															
	1F																

*1. Assignment at default values.

● At Error Handling Switching

Link De-vice	Word Address (Start number +)	Bit Address															
		F	E	D	C	B	A	9	8	7	6	5	4	3	2	1	0
RX	0□	Digital input (port 0-F: corresponds to bit address 0-F)															
	1□	Error	IO-Link Ready	Synchronization establishment	Reserved				RY1F copy	Event	External power supply	Output overcurrent	Reserved				RY17 copy

Link Device	Word Address (Start number +)	Bit Address															
		F	E	D	C	B	A	9	8	7	6	5	4	3	2	1	0
RY	0□	Digital output (port 0-F: corresponds to bit address 0-F)															
	1□	Clear oldest error	Error handling switching	Reserved						Clear the latest event	Reset encoder counter	Reserved					
RW _r	00	Process input data port 0* ¹															
	01																
	02	Process input data port 1* ¹															
	03																
															
	1E	Process input data port F* ¹															
	1F																
RW _w	00	Process output data port 0* ¹															
	01																
	02	Process output data port 1* ¹															
	03																
															
	1E	Process output data port F* ¹															
	1F																

*1. Assignment at default values.

Process input and output data are assigned two words (four bytes) per port at default values. They can be changed to either of the following.

Refer to *Process data automatic allocation/manual setting* in 4-1 *Product Functions* on page 4-2 for function details.

- Specify *Process input data words allocation* and *Process output data words allocation* and manually designate those without allocation or with word numbers other than 2 (4 bytes)
- or,
- Run *Process data auto allocation* to automatically allocate from the actual IO-Link device

● Assigned Data Content

- Digital input/digital output in SIO mode and product status/operation flags

Type and direction	Assignment	Category	Host master station assigned link device address (Start number +)	Data Name	Description
Input from this product	Host master station remote input (RX)	Digital input in SIO mode	RX00 to 0F	Digital input (port 0-F)	Digital input data in SIO mode (PNP input or NPN input). In IO-Link mode, the least-significant value of the bit data defined in process input data format is reflected. (This function does not exist on the process output data side.)

Type and direction	Assignment	Category	Host master station assigned link device address (Start number +)	Data Name	Description
		Status of this product	RX1F	Error flag	Turns ON when an error is generated in this product. When this flag is ON, access the <i>Latest error code readout by port</i> through acyclic communication. Refer to 3-4-2 <i>Acyclic Communication (Transient Transmission/ISDU Communication)</i> on page 3-31 for <i>Latest error code readout by port</i> data.
			RX1E	IO-Link ready flag	When communication is established with all IO-Link devices, and CC-Link IE Field/TSN with the host master station, if this flag is ON, execute read and write with the IO-Link devices through cyclic or acyclic communication. Note This flag will turn ON even when not all ports' I/O setting assignments are in IO-Link mode.
			RX1D	Synchronization establishment flag (for CC-Link IE TSN only)	Turns on in CC-Link IE TSN, when I/O synchronization (set value number: M21) is set to any of 2/3/4/5/6 (0.4 ms/0.8 ms/1.6 ms/3.2 ms/6.4 ms cycle), while the internal timer in this product is synchronized (within +/-20 μs) with the network time. Normally OFF for CC-Link IE Field.
			RX18-1C	Latest error port	Port number of the latest generated error. When accessing the <i>Latest error code readout by port</i> through acyclic communication, specify the port based on this value.
			RX17	Event flag	Turns ON when an event is occurring in one of the connected IO-Link devices. When this flag is ON, access the <i>Event data readout by port</i> data through acyclic communication. Refer to 3-4-2 <i>Acyclic Communication (Transient Transmission/ISDU Communication)</i> on page 3-31 for <i>Latest event data readout by port</i> .
			RX16	I/O power supply flag	Turns ON when power is being supplied for I/O by the I/O power supply.
			RX15	Output over-current flag	Turns ON when overcurrent is generated in SIO (output).
			RX10 to 13	Latest Event port	Port number of the latest generated event. When accessing the <i>Event data readout by port</i> through acyclic communication, specify the port based on this value.
			Output to this product	Host master station remote output (RY)	Digital output in SIO mode
Unit operation flag	RY1F	Clear the latest error			Clears the latest error when starting up from OFF to ON.
	RY17	Clear the latest event			Clears the latest event when starting up from OFF to ON.
	RY16	Reset encoder counter			If the SIO device is an encoder, the high-speed counter in this product will be reset when starting up from OFF to ON.
	RY10	Extended access enable flag			Specify extended access disabled (normal) assignment as the assignment method for the cyclic communication area. OFF: Extended access disabled



Additional Information

Below, this manual explains how to indicate the product status/operation flag link device address with RX/RX setting start number 00.

Ex.: Event flag: RX17, Latest Event port: RX10-13

- Process data

Type and direction	Assignment	Host master station assigned link device address (Start number +)	Data Name	Description
Input from IO-Link devices	Host master station remote register (RWr)	RWr00 to 1F	Process input data Ports 0-F	Process input data in IO-Link communication mode. Total of 256 words for all ports. The data exceeding 256 words will be ignored (not transferred from IO-Link devices to the product).
Output to IO-Link devices	Host master station remote register (RWW)	RWW00-1F	Process output data Ports 0-F	Process output data in IO-Link communication mode. Total of 256 words for all ports. The data exceeding 256 words will be ignored (not transferred from the product to the IO-Link devices).

Extended Access Enabled Assignment

If *Extended access enable flag* (RY10) is turned ON (extended access enabled), this product will be assigned to the master station link device as follows.

The area in yellow below is data only when extended access is enabled.

● Assignment of Host Master Station Link Devices

Link Device	Word Address (Start number +)	Bit Address															
		F	E	D	C	B	A	9	8	7	6	5	4	3	2	1	0
	0□	Digital input (port 0-F: corresponds to bit address 0-F)															
RX	1□	Error	IO-Link Ready	Synchronization establishment	Access error	Latest error port			Event	I/O power supply	Output overcurrent	Access completed	Latest Event port				

Link Device	Word Address (Start number +)	Bit Address															
		F	E	D	C	B	A	9	8	7	6	5	4	3	2	1	0
RY	0□	Digital output (port 0-F: corresponds to bit address 0-F)															
	1□	Clear the latest error	Reserved	Little endian access	To access GD-ILM16C/E-CLI parameters	Applicable IO-Link port (0 to F)				Clear the latest event	Reset encoder counter	Reserved			Write request	Read request	Extended access enabled
RWr	00	Process input data port 0*1															
	01																
	02	Process input data port 1*1															
	03																
															
	1C	Process input data port E*1															
	1D																
	1E	Extended access read data															
1F																	
RWw	00	Process output data port 0*1															
	01																
	02	Process output data port 1*1															
	03																
															
	1A	Process output data port D*1															
	1B																
	1C	Index number or setting value number specification															
	1D	Reserved				Byte length or target selection to access				Subindex number or target number							
	1E	Extended access write data															
1F																	

*1. Process input and output data are assigned two words per port at default values.

This can be changed to the following using the *M40. Process input data words allocation* and *M41. Process output data words allocation* Master Unit parameters of this product.

No assignment, or other number of words

The *M42. Process data words auto allocation* Master Unit parameter of this product can be used to automatically set M40/M41 above based on the specifications of the actual IO-Link device.

● Assignment Data Content (When Extended Access Is Enabled)

- Digital input/digital output in SIO mode and product status/operation flags

Type and direction	Assignment	Category	Host master station assigned link device address (Start number +)	Data Name	Description
Input from this product	Host master station remote input (RX)	Digital input in SIO mode	RX00 to 0F	Digital input (port 0 to F)	Digital input data in SIO mode (PNP input or NPN input). In IO-Link mode, the least-significant value of the bit data defined in process input data format is reflected. (This function does not exist on the process output data side.)
		Status of this product	RX1F	Error flag	Turns ON when an error is generated in this product. When this flag is ON, access the <i>Latest error code readout by port</i> through acyclic communication. Refer to <i>3-4-2 Acyclic Communication (Transient Transmission/ISDU Communication)</i> on page 3-31 for <i>Latest error code readout by port</i> data.
			RX1E	IO-Link ready flag	When communication is established with all IO-Link devices, and CC-Link IE Field/TSN with the host master station, if this flag is ON, execute read and write with the IO-Link devices through cyclic or acyclic communication. Note This flag will turn ON even when not all ports' I/O setting assignments are in IO-Link mode.
			RX1D	Synchronization establishment flag (for CC-Link IE TSN only)	Turns on when I/O synchronization (setting value number: M21) is set to any of 2/3/4/5/6 (0.4 ms/0.8 ms/1.6 ms/3.2 ms/6.4 ms cycle), while the internal timer in this product is synchronized (within $\pm 20 \mu\text{s}$) with the network time. Normally OFF for CC-Link IE Field.
			RX1C	Access error (Only when extended access is enabled)	If an error occurs when requesting reading/writing, this turns on along with the access completed bit.
			RX18 to 1B	Latest error port	Port number of the latest generated error. When accessing the <i>Latest error code readout by port</i> through acyclic communication, specify the port based on this value.
			RX17	Event flag	Turns ON when an event is occurring in one of the connected IO-Link devices. When this flag is ON, access the <i>Event data readout by port</i> data through acyclic communication. Refer to <i>A-1 Acyclic Communication Sample Programs</i> on page A-2 for <i>Latest event data readout by port</i> .
			RX16	I/O power supply flag	Turns ON when power is being supplied for I/O by the I/O power supply.
			RX15	Output overcurrent flag	Turns ON when overcurrent is generated in SIO (output).

Type and direction	Assignment	Category	Host master station assigned link device address (Start number +)	Data Name	Description
			RX14	Access completed (Only when extended access enabled assignment is enabled)	Turns ON when reading/writing has completed. If the read/write request bit turns OFF, this bit will turn OFF also.
			RX10 to 13	Latest Event port	Port number of the latest generated event. When accessing the <i>Event data readout by port</i> through acyclic communication, specify the port based on this value.
Output to this product	Host master station remote output (RY)	Digital output in SIO mode	RY00 to 0F	Digital output (port 0 to F)	Digital output data in SIO mode (PNP output or NPN output).
		Unit operation flag	RY1F	Clear the latest error	Clears the latest error when starting up from OFF to ON.
			RY1D	Little endian access (Only when extended access enabled assignment is enabled)	Specify the byte unit order for <i>Extended access read data</i> or <i>Extended access write data</i> . ON: Read and write service data (setting values, etc.) in the IO-Link device in little endian format. Turn this ON when reading and writing general service data in the IO-Link device. OFF: Read and write service data (setting values, etc.) in the IO-Link device in big endian format.
			RY1C	To access GD-ILM16C/E-CLI parameters (Only when extended access enabled assignment is enabled)	Specify whether to set the target for extended access to this product or an IO-Link device. ON: Specify to access the Master Unit parameters of this product. Note Master Unit parameter data of this product will be read and written in little endian format (fixed). OFF: Specify to access service data (setting values, etc.) in the IO-Link device.
			RY18 to RY1B	Port No. of IO-Link to access (0 to F) (Only when extended access is enabled)	If "To access GD-ILM16C/E-CLI parameters" is OFF, specify the IO-Link device port number to access.
			RY17	Clear the latest event	Clears the latest event when starting up from OFF to ON.
			RY16	Reset encoder counter	If the SIO device is an encoder, the high-speed counter in this product will be reset when starting up from OFF to ON.
			RY12	Write request (Only when extended access enabled assignment is enabled)	Specified data writing begins when this bit is switched ON.
			RY11	Read request (Only when extended access enabled assignment is enabled)	Specified data reading begins when this bit is switched ON.

Type and direction	Assignment	Category	Host master station assigned link device address (Start number +)	Data Name	Description
			RY10	Extended access enable flag	Specify extended access enabled assignment as the assignment method for the cyclic communication area. ON: Extended access enabled

- Process data, extended access-related data

Type and direction	Assignment	Category	Host master station assigned link device address (Start number +)	Data Name	Description
Input from this product to host master station	Host master station remote register (RWr)	Input from IO-Link devices	RWr00 to RWr1D	Process input data Port 0 to E	Process input data in IO-Link communication mode. Two words (four bytes) per port at default values.
		Extended access read data	RWr1E, RWr1F	Extended access read data	The value read during extended access. Two words (four bytes). If <i>Little endian access</i> is ON, the byte address +500 will be the lowest-order byte. <ul style="list-style-type: none"> • For a read request, data read from the target (this product or IO-Link device) will be stored. • For a write request, a value of 0 will be stored when the operation is complete. • If there is an access error, the extended access error code will be stored. For more informations on the extended access error code, refer to <i>List of extended access error codes</i> described later.
Output from host master station to this product	Host master station remote register (RWw)	Output to IO-Link devices	RWw00 to 1B	Process output data Port 0 to D	Process output data in IO-Link communication mode. Two words (four bytes) per port at default values.
		Extended access specified data	RWw1C	Index number or setting value number specification	If "Byte length or target selection to access" is set to 1 to 4 (read and write data for one to four bytes), specify the index number of the service data (setting values, etc.) in the applicable IO-Link device, or the setting value number of the IO-Link device settings for this product or the Master Unit parameters of this product.
			RWw1C bit address 8 to F	Unused	-

Type and direction	Assignment	Category	Host master station assigned link device address (Start number +)	Data Name	Description
			RWw1D bit address 8 to A	Byte length or target selection to access	Specify whether to set the read and write target to the IO-Link device connected to a port or the Master Unit parameter of this product (if so, also specify the data size for simultaneously reading and writing). 0: Unused 1 to 4: Reads and writes one- to four-byte data (The read and write target is the connected IO-Link device or Master Unit parameters of this product.)
		RWw1D bit address 8 to A	RWw1D bit address 0 to 7	Subindex number or target number	If "Byte length or target selection to access" is set to 1 to 4 (read and write data for one to four bytes), specify the subindex number of the service data (setting values, etc.) in the applicable IO-Link device, or the target number of the Master Unit parameters of this product.
		Extended access write data	RWw1E, RWw1F	Extended access write data	Specify the setting value to write via extended access. The data length is two words (four bytes) maximum. For a write request, this value will be sent to the target (this product or IO-Link device). If <i>Little endian access</i> is ON, RWw1E bit address 0 through 7 will be the lowest-order byte.

Note The IO-Link device process data will be converted to little endian format in this product at default values. The *Process data sequence conversion* Master Unit parameter can be used to change this to big endian format for each port.

- Extended access error code list

The following error codes are stored in the front byte (RWw1E bits 0 through 7) of the extended access read data when an access error occurs during extended access.

Error Code	Details
11 h	The specified index number does not exist in the IO-Link device for which reading was attempted.
23 h	Failed to write setting value (attempted to write a read-only setting value).
30 h	Outside the range of setting value write data.
33 h	The setting value data for which writing was attempted is too long.
34 h	The read setting value data length is 0 (read error).
80 h	The port number to be accessed is out of range.
81 h	The IO-Link device for which setting value writing was attempted is not connected.
82 h	The IO-Link device for which setting value writing was attempted does not support ISDU communication.
94 h	Cannot be executed when the storage function is BUSY.

Process Data Reading and Writing Methods

When the IO-Link ready flag is ON and the CC-Link IE Field/TSN data link is normal, read process data.

Ex.: Reading process input data from the port n IO-Link device

With input conditions of link device assigned the IO-Link Ready flag (for instance X101E) ON and SW00B0.0 (data link status of each station; when product station number = 1) OFF, read out.

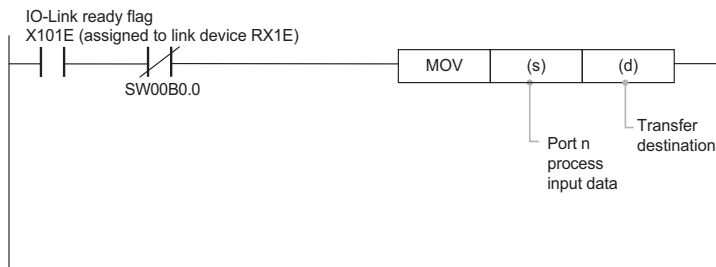

When the IO-Link ready flag is ON and the CC-Link IE Field/TSN data link is normal, write process data.

Ex.: Writing process output data from the port n IO-Link device

With input condition of link device assigned the IO-Link Ready flag (for instance X101E) ON, write.

Because there is a communication abnormality when the IO-Link ready flag is OFF, handle data transfer destinations suitably.

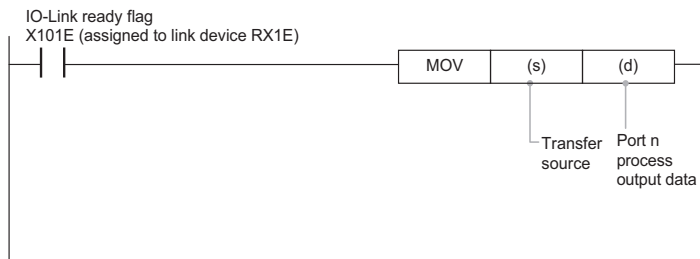

Process Data Words Allocation Example

This product Port number	IO-Link Device Process data size example		This product Result of product auto allocation execution		Host master station Remote register		Host master station actual device example	
	Process input data byte count	Process output data byte count	Process input data word count	Process output data word count	RWr (address hexadecimal) Ex.: RWw/RWr start: 00	RWw (address hexadecimal) Ex.: RWw/RWr start: 00	Ex.: W100 up (address hexadecimal)	Ex.: W200 up (address hexadecimal)
0	2	0	1	0	RWr00	-	W100	-
1	2	0	1	0	RWr01	-	W101	-
2	0	2	0	1	-	RWw00	-	W200
3	Not used		0	0				
4	4	0	2	0	RW0r2 - 03	-	W102 - 103	-
5	3	0	2	0	RWr04 - 05	-	W104 - 105	-
6	Not used		0	0				
7	Not used		0	0				

This product Port number	IO-Link Device Process data size example		This product Result of product auto allocation execution		Host master station Remote register		Host master station actual device example	
	Process input data byte count	Process output data byte count	Process input data word count	Process output data word count	RWr (address hexadecimal) Ex.: RWw/RWr start: 00	RWw (address hexadecimal) Ex.: RWw/RWr start: 00	Ex.: W100 up (address hexadecimal)	Ex.: W200 up (address hexadecimal)
8	16	0	8	0	RWr06 - 0D	-	W106 - 10D	-
9	0	1	0	1	-	RWw01	-	W201
A	Not used		0	0				
B	Not used		0	0				
C	Not used		0	0				
D	4	0	2	0	RWr0E - 0F	-	W10E - 10F	-
E	Not used		0	0				
F	Not used		0	0				



Precautions for Correct Use

If more than 256 words are used on either the input or the output in total, the excess process data will not be assigned to the host master station (and will be ignored).

To connect a maximum of 16 IO-Link devices to this product, the following conditions are required.

Product process data size with the connected IO-Link device group:

Input: Up to 256 words in total for all ports

Output: Up to 256 words in total for all ports

- When the IO-Link ready flag is ON, read and write process data.

3-4-2 Acyclic Communication (Transient Transmission/ISDU Communication)

This function exchanges data as needed with the CC-Link IE Field/TSN master station or GXWorks2/3, by responding to a communication instruction from the CC-Link IE Field/TSN master station or a request from GXWorks2/3.

In response to the product Master Unit parameters, designate a Master Unit parameter number and target number for access.

For the details of product Master Unit parameter numbers and target numbers, refer to *3-4 CC-Link IE Field/TSN Communication and IO-Link Communication with This Product* on page 3-20.

The following communication instructions are used from the CC-Link IE Field/TSN master station.

- For CC-Link IE Field communication: RIRD/RIWT instructions
- For CC-Link IE TSN communication: SLMPSND instructions

See below for details of the communication instructions used.

- RIRD/RIWT instruction

For a Q Series PLC: Mitsubishi Electric Corporation *MELSEC-Q CC-Link IE Field Network Master/Local Module User's Manual*

For an iQ-R Series PLC: *MELSEC iQ-R Programming Manual (Module Dedicated Instructions)*

- SLMPSND instruction

MELSEC iQ-R Programming Manual (Module Dedicated Instructions)

Further, this product can perform acyclic communication (ISDU communication) with IO-Link devices based on transient transmission from the CC-Link IE Field/TSN master station.

When needed, access the IO-Link devices via this product from the CC-Link IE Field/TSN master station or product front panel operation. Mainly reads and writes service data such as parameters, identification data or diagnosis information data within the IO-Link devices.

When the IO-Link ready flag is ON, read and write IO-Link device service data.

Refer to each IO-Link device index list for their index numbers and subindex numbers.

For CC-Link IE Field Communication

Readout of product Master Unit parameters or IO-Link device service data uses RIRD instructions (reading), while writing uses RIWT instructions (writing).

● How To Use RIRD Instructions for Readout



Operand	Details
(J)	Own station network No.
(S)	Start device of own station storing control data (*1)
(d1)	Start device of own station storing read data (*2)
(d2)	Own station device turning 1 scan ON when instruction complete (D2)+1 also turns ON at abnormality complete.

*1: Control data:

Device	Item	Settings data
(S)+0	Completion status	Status at instruction complete is stored. 0: Normal, Non-0: Abnormal (Refer to <i>Dedicated error codes</i> below)
(S)+1	Target station number	Specifies the number of the target station. 1 - 120
(S)+2	Access code/Attribute code	Specifies the access code and attribute code of the readout device. <div style="text-align: center;"> Bit 15 8 7 0 <div style="border: 1px solid black; width: 100%; height: 15px; position: relative;"> Access code Attribute code </div> </div>
(S)+3	Device number	Specifies the start number of the readout device.
(S)+4	Number of read points	Specifies the data count of the readout device in word units.

• Access code

0x80 - 0x8F	Access to IO-Link devices (0-15ch)
0xC0 - 0xCF	Specifies access to IO-Link devices (0-15ch) for 4 bytes or less of read/write data as little-endian.
0xFF	Access to this product

• Attribute code

0x00 - 0xFF	<ul style="list-style-type: none"> To this product: Target number To IO-Link devices: Subindex number
--------------------	---

- Device number

0x0000 - 0xFFFF	<ul style="list-style-type: none"> • To this product: Master Unit parameter • To IO-Link devices: Index number
------------------------	--

- Number of read points

The number of read points is determined by $(\text{value of read data byte count} + 1) / 2 + 1$. Configure according to the amount of data required.

The value of read is stored in the format below (d1).

*2: Value of read:

+0	Readout byte count
+1	Value of read (little endian format)
+2	Continuing data

- Dedicated error codes

Error codes generated during readout of product Master Unit parameters or IO-Link device service data are as below.

Error code ((S)+0)	Details
0xD211	The specified index number does not exist in the IO-Link device for which reading was attempted.
0xD223	The setting value write operation failed. (Attempted to write a read-only set value)
0xD230	Outside the range of set value write data.
0xD233	The set value data for which writing was attempted is too long.
0xD234	The read set value data length is 0. (Readout error)
0xD280	The port number to be accessed is out of range.
0xD281	The IO-Link device for which set value writing was attempted is not connected.
0xD282	The IO-Link device for which set value writing was attempted does not support ISDU communication.
0xD294	Cannot be executed when the storage function is BUSY.

● How To Use RIWT Instructions for Writing

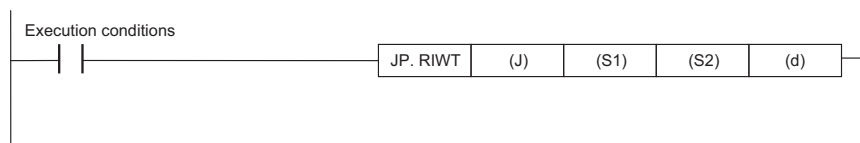

Operand	Details
(J)	Own station network No.
(S1)	Start device of own station storing control data (*1)
(S2)	Start device of own station storing write data (*2)
(d)	Own station device turning 1 scan ON when instruction complete (d2)+1 also turns ON at abnormality complete.

*1: Control data:

Device	Item	Settings data
(S1)+0	Completion status	Status at instruction complete is stored. 0: Normal, Non-0: Abnormal
(S1)+1	Target station number	Specifies the number of the target station. 1 - 120
(S1)+2	Access code/Attribute code	Specifies the access code and attribute code of the write device. <div style="text-align: center;"> Bit 15 8 7 0 <div style="border: 1px solid black; width: 100%; height: 15px; position: relative;"> Access code Attribute code </div> </div>
(S1)+3	Device number	Specifies the start number of the write device.
(S1)+4	Write points	Specifies the data count of the write device in word units.

• Access code

0x80 - 0x8F	Access to IO-Link devices (0-15ch)
0xC0 - 0xCF	Specifies access to IO-Link devices (0-15ch) for 4 bytes or less of write data as little-endian.
0xFF	Access to this product

• Attribute code

0x00 - 0xFF	<ul style="list-style-type: none"> • To this product: Target number • To IO-Link devices: Subindex number
--------------------	---

• Device number

0x0000 - 0xFFFF	<ul style="list-style-type: none"> • To this product: Master Unit parameter • To IO-Link devices: Index number
------------------------	--

• Write points

The number of write points is determined by $(\text{value of write data byte count} + 1) / 2 + 1$. Configure according to the amount of data required.

Store the write data in (S2) below.

*2: Write data:

+0	Write byte count
+1	Write data (little endian format)
+2	Continuing data

For CC-Link IE TSN Communication

Readout and writing of product Master Unit parameters or IO-Link device service data uses SLMPSND instructions. The readout command is 0613 h and the write command is 1613 h.

● How to use SLMPSND instructions for readout

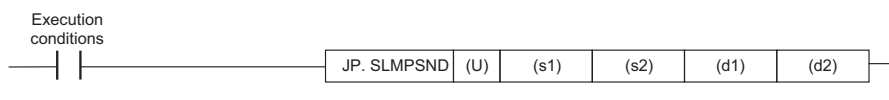

Operand	Details
(U)	Dummy
(s1)	Start device storing control data (*1)
(s2)	Start device storing request frame (*2)
(d1)	Starting device that stores response frames
(d2)	Device turning 1 scan ON when instruction complete

*1: Control data:

Device	Item	Settings data
(s1)+0	Execution/error completion type	
(s1)+1	Completion status	
(s1)+2	Own station channel	
(s1)+3	IP address of external device (Lower)	
(s1)+4	IP address of external device (Upper)	
(s1)+5	Destination port number	For the SLMP communication port number, specify B0B7 h.
(s1)+6	Request destination network No.	
(s1)+7	Request destination station number	
(s1)+8	Request destination module I/O number	
(s1)+9	Request destination multidrop station number	
(s1)+10	Number of resends	
(s1)+11	Arrival monitoring time	

*2: Request frame:

Device	Item	Settings data										
(s2)+0	Request data length											
(s2)+1	Monitoring timer											
(s2)+2	Request data	Command: For SLMP readout, 0613 h										
(s2)+3		Subcommand: 0000 h										
(s2)+4		Address (Lower): Address specification <ul style="list-style-type: none"> For this product, Master Unit parameter number set value Ex.: Readout display text string (1st row): 107 h For IO-Link devices, their index number 										
(s2)+5		Address (Upper): Unit specification and address specification below <div style="text-align: center; margin: 10px 0;"> <table border="1" style="border-collapse: collapse; width: 100%;"> <tr> <td style="text-align: left; padding: 2px;">Bit</td> <td style="text-align: center; padding: 2px;">15</td> <td style="text-align: center; padding: 2px;">8</td> <td style="text-align: center; padding: 2px;">7</td> <td style="text-align: center; padding: 2px;">0</td> </tr> <tr> <td></td> <td colspan="2" style="text-align: center; padding: 2px;">Specify unit</td> <td colspan="2" style="text-align: center; padding: 2px;">Specify sub-address</td> </tr> </table> </div> <ul style="list-style-type: none"> Bits 15 - 8: Unit specification Specifying this product: FF h Specifying ports 0 - 15 IO-Link devices: 80 h - 8F h Bits 7 - 0: Subaddress specification For this product, the target number. Ex.: Specify 1st row of display text string: 00 h For IO-Link devices, their index number. 	Bit	15	8	7	0		Specify unit		Specify sub-address	
Bit		15	8	7	0							
	Specify unit		Specify sub-address									
(s2)+6	Readout word count											

● How To Use SLMPSEND Instructions For Writing

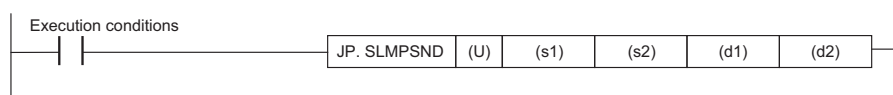

Operand	Details
(U)	Dummy
(s1)	Start device storing control data (*1)
(s2)	Start device storing request frame (*2)
(d1)	Starting device that stores response frames
(d2)	Device turning 1 scan ON when instruction complete

*1: Control data:

Device	Item	Settings data
(s1)+0	Execution/error completion type	
(s1)+1	Completion status	
(s1)+2	Own station channel	
(s1)+3	IP address of external device (Lower)	
(s1)+4	IP address of external device (Upper)	
(s1)+5	Destination port number	For the SLMP communication port number, specify B0B7 h.
(s1)+6	Request destination network No.	
(s1)+7	Request destination station number	
(s1)+8	Request destination module I/O number	
(s1)+9	Request destination multidrop station number	
(s1)+10	Number of resends	
(s1)+11	Arrival monitoring time	

*2: Request frame:

Device	Item	Settings data
(s2)+0	Request data length	
(s2)+1	Monitoring timer	

Device	Item	Settings data
(s2)+2	Request data	Command: For SLMP writing, 1613 h
(s2)+3		Subcommand: 0000 h
(s2)+4		Address (Lower): Address specification <ul style="list-style-type: none"> For this product, Master Unit parameter number set value Ex.: I/O assignment settings: 10(A h) For IO-Link devices, their index number
(s2)+5		Address (Upper): Unit specification and address specification below <div style="text-align: center; margin: 10px 0;"> Bit 15 8 7 0 <div style="border: 1px solid black; width: 100%; height: 15px; position: relative;"> <div style="position: absolute; top: -10px; left: 0px;">15</div> <div style="position: absolute; top: -10px; left: 50px;">8 7</div> <div style="position: absolute; top: -10px; left: 90px;">0</div> <div style="position: absolute; top: 5px; left: 25%; width: 30%; border-bottom: 1px solid black; text-align: center;">Specify unit</div> <div style="position: absolute; top: 5px; left: 65%; width: 30%; border-bottom: 1px solid black; text-align: center;">Specify sub-address</div> </div> </div> <ul style="list-style-type: none"> Bits 15 - 8: Unit specification Specifying this product: FF h Specifying ports 0 - 15 IO-Link devices: 80 h - 8F h Bits 7 - 0: Subaddress specification For this product, the target number. Ex.: I/O assignment settings target port 0: 00 h For IO-Link devices, their index number.
(s2)+6		Number of words written
(s2)+7	Write data Ex.: When setting the I/O assignment to 2 (NPN input): 0002 h	

3-4-3 Event Communication

If there is a disconnection, etc., with an IO-Link device on a given port, the product spontaneously receives the event code and event type sent from the IO-Link device and saves it in product memory. At this time, the event flag (allocated to host master station RX17) turns ON, and the port number where the event took place is stored in *Latest Event port* (allocated to host master station RX10-13). On this condition, from CC-Link IE Field/TSN master station communication instructions, it is possible to access the Master Unit parameter *event data readout* and read out the event code and event type.

Thereby, the following IO-Link device phenomena can be grasped on the host master station side when they occur.

Errors (ex.: breakdowns, short-circuits) and maintenance information (ex.: maintenance predictive period complete)

Refer to each IO-Link device index list for their event codes.

3-5 Parameter Setting/Monitoring Inside IO-Link Devices

This section explains how to set parameters inside IO-Link devices connected to the product. As shown below, there are two setting methods.

- Setting with communication instructions from host master station
- Setting with product front panel operation

Note When there is event communication from an IO-Link device, the *event data readout* in the product's Master Unit parameters is read out by communication instructions or product front panel operation.

3-5-1 Reading/Writing IO-Link Device Data via Host Master Station Communication Instructions

Using IO-Link acyclic (ISDU) communication, IO-Link device service data can be read and written. This product's Master Unit parameters can be set using the following communication instructions on a Mitsubishi Electric PLC.

- CC-Link IE Field communication: RIRD instructions (read), RIWT instructions (write)
Refer to the manuals below for further information on instructions.
For a Q Series PLC: Mitsubishi Electric Corporation *MELSEC-Q CC-Link IE Field Network Master/Local Module User's Manual*
For an iQ-R Series PLC: *Mitsubishi Electric MELSEC iQ-R Programming Manual (Module Dedicated Instructions)*
- CC-Link IE TSN communication: SLMPSND instructions
Refer to the manuals below for further information on instructions.
Mitsubishi Electric MELSEC iQ-R Programming Manual (Module Dedicated Instructions)

3-5-2 Parameter Settings inside IO-Link Devices Connected to This Product, via Product Front Panel Operation

It is also possible to set parameters within IO-Link devices via product front panel operation. From the *Device setting* window, reading and writing of arbitrary index numbers is possible. Refer to *5-1-4 Device Setting Value Window* on page 5-6 for further information.

3-6 Specific Communication Examples (Including Sample Programs)

3-6-1 Example of Cyclic Communication

Example Combining IO-Link Communication and SIO

Process input data (4 bytes) from the port 0 IO-Link device is read from the lower direction (default value).

Process output data (4 bytes) to the port 1 IO-Link device is written from the upper direction.

Reads bit input data from the port 2 SIO device (NPN type presence sensor).

Host master side refresh settings

Link Side					CPU Side				
Device Name	Points	Start	End		Target	Device Name	Points	Start	End
RX	32	00000	001F	↔	Specified Device	X	32	01000	0101F
RY	32	00000	001F	↔	Specified Device	Y	32	01000	0101F
RWr	32	00000	001F	↔	Specified Device	W	32	00100	0011F
RWw	32	00000	001F	↔	Specified Device	W	32	00200	0021F

Product CC-Link IE Field/TSN station number: Ex.: 1

Product Master Unit settings:

- I/O assignment function setting (set value number: M10)
Port 0: IO-Link, port 1: IO-Link, port 2: NPN input
- Process data sequence conversion (set value number: M43):
Port 1: Big endian MSB

Master side program example:

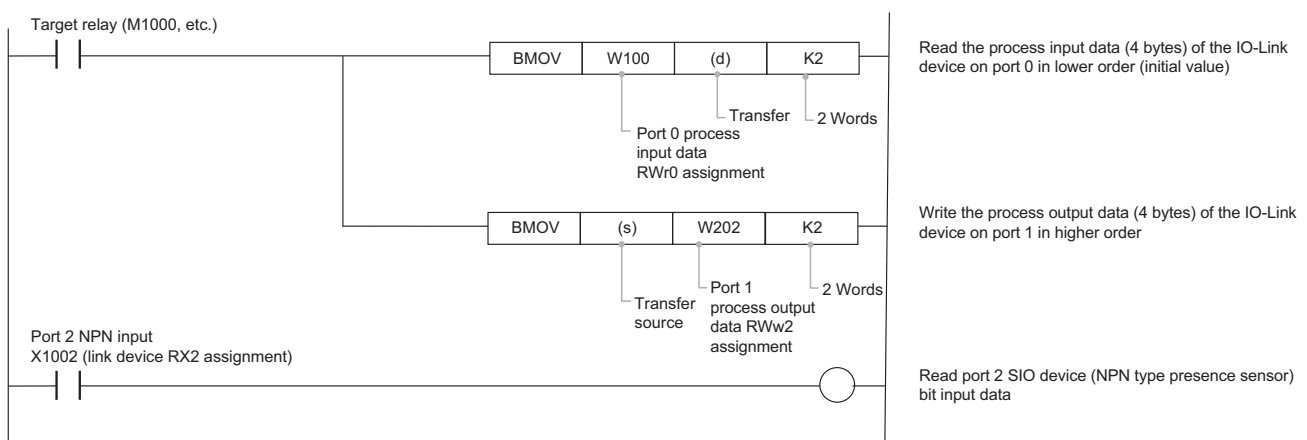

Word Assignment of Input and Output Process Data for IO-Link Devices

An example of IO-Link process data (RWr, RWw) allocation is shown below.

Master Unit parameter M43. Process data LSB/MSB

Setting Details

Little endian LSB *default

Big endian MSB

Little endian MSB

Swap bytes

The byte order of RWr/RWw changes depending on the above settings.

IO-Link device process data (when the number of bytes is even)

Byte
n+0
n+1
n+2
n+3
n+4
n+5

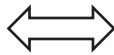

Example: 6 bytes in total

Endianness of the IO-Link Master Unit process data after word conversion

Word	Upper	Lower
N+0	n+4 byte	n+5 byte
N+1	n+2 byte	n+3 byte
N+2	n+0 byte	n+1 byte

Word	Upper	Lower
N+0	n+1 byte	n+0 byte
N+1	n+3 byte	n+2 byte
N+2	n+5 byte	n+4 byte

Word	Upper	Lower
N+0	n+4 byte	n+5 byte
N+1	n+2 byte	n+3 byte
N+2	n+0 byte	n+1 byte

Word	Upper	Lower
N+0	n+0 byte	n+1 byte
N+1	n+2 byte	n+3 byte
N+2	n+4 byte	n+5 byte

Master Unit parameter M43. Process data

Little endian LSB *default

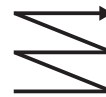

Big endian MSB



Little endian MSB

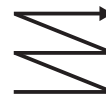

Swap bytes



IO-Link device process data (when the number of bytes is **odd**)

Byte
n+0
n+1
n+2
n+3
n+4



Example: 5 bytes in total

Endianness of the IO-Link Master Unit process data after word conversion

Word	Upper	Lower
N+0	n+3 byte	n+4 byte
N+1	n+1 byte	n+2 byte
N+2	0x00 (Fixed)	n+0 byte

Word	Upper	Lower
N+0	n+1 byte	n+0 byte
N+1	n+3 byte	n+2 byte
N+2	0x00 (Fixed)	n+4 byte

Word	Upper	Lower
N+0	n+4 byte	0x00 (Fixed)
N+1	n+2 byte	n+3 byte
N+2	n+0 byte	n+1 byte

Word	Upper	Lower
N+0	n+0 byte	n+1 byte
N+1	n+2 byte	n+3 byte
N+2	n+4 byte	0x00 (Fixed)

Master Unit parameter M43. Process data

Little endian LSB *default

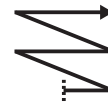

Big endian MSB



Little endian MSB

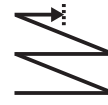

Swap bytes



3-6-2 Example of Acyclic Communication

Below is an example of using acyclic communication to read and write IO-Link device service data.

- CC-Link IE Field communication:
RIRD instruction (readout), RIWT instruction (write)

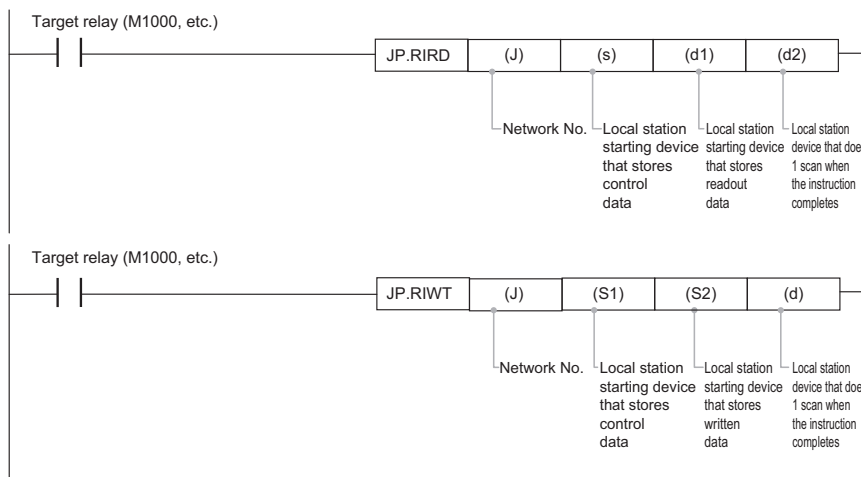

- CC-Link IE TSN communication:
SLMPSND instructions

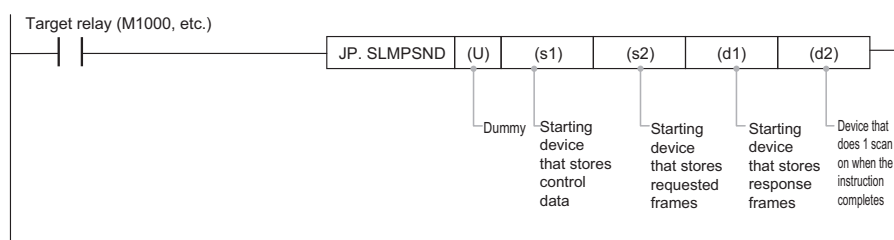

Readout of Event Code when Event Occurs

When the event flag (process input data word address 10 h, bit address 7 h) is ON, read out the following via host master station communication instructions.

- Latest event generated port (process input data word address 10 h, bit address 0-3 h) = n
- Index number 101 h subindex number n, offset +0: event flag, offset +1: event #1 type, offset +2-+3: event code

Readout of Error Code when Error Occurs

When the error flag (process input data word address 10 h, bit address F h) is ON, read out the following via host master station communication instructions.

- Latest error generated port (process input data word address 10 h, bit address 8-B h) = n
- Index number 100 h subindex number n, offset +0-+1: port n latest error code



Product Functions

This section describes the functions of this product.

4-1	Product Functions.....	4-2
-----	------------------------	-----

4-1 Product Functions

Following is a list of product functions.

Category	Function	I/O as- sign- ment settings	Product Functions
Basic IO- Link com- munication	<ul style="list-style-type: none"> Cyclic com- munication 	IO-Link mode	<ul style="list-style-type: none"> Product flags (status and operation): Number of points used for host master station remote input (RX): 32 Number of points used for host master station remote output (RY): 32 <p>(The RX/RX addresses below are indicated offset from the start number.) RX0 - RXF: Digital input data in SIO mode (PNP input or NPN input) RX10 - RX1F: Following flags</p> <ul style="list-style-type: none"> IO-Link ready Error Latest error port Event Latest event port I/O power supply Output overcurrent (during PNP output or NPN output) <p>RY0 - RYF: Digital output data in SIO mode (PNP output or NPN output) RY10 - RY1F: Following flags</p> <ul style="list-style-type: none"> Clear the latest error Clear the latest event Reset encoder counter <ul style="list-style-type: none"> Process input data and process output data with IO-Link device: Number of points used for host master station remote register (RWr): 32 words (64 bytes) Number of points used for host master station remote register (RWw): 32 words (64 bytes) RWr0 - RWr1F (hexadecimal) RWw0 - RWw1F (hexadecimal) <p>There is a maximum of 16 ports. The number of usable ports is determined by the number of words occupied per single IO-Link device. By default, the number of assigned words for an IO-Link device is as follows (Extended access disabled). Input: Two words per single port. 32 total words (64 bytes) across all ports, with two words for each of 16 ports. Output: Two words per single port. 32 total words (64 bytes) across all ports, with two words for each of 16 ports.</p>

Category	Function	I/O assignment settings	Product Functions
			<p>The above default values can be changed to either of the following.</p> <ul style="list-style-type: none"> • Run <i>Process data auto allocation</i> to automatically allocate from the actual IO-Link device • Specify <i>Process input data words allocation</i> and <i>Process output data words allocation</i> for no allocation or to manually set a number of words other than two <p>Note 1. When either input or output exceeds a total of 256 words (512 bytes), the process data exceeding the total will not be assigned to the host master station (it will be ignored).</p> <p>Note 2. Error codes are not allocated. If the error flag is ON, acyclic communication will need to be used to read from the host master station.</p> <p>Note 3. Event codes are not allocated. If the event flag is ON, acyclic communication will need to be used to read from the host master station.</p>
Basic IO-Link communication	<ul style="list-style-type: none"> • Acyclic communication 	IO-Link mode	<p>Acyclic communication is performed using RIRD/RIWT instructions (during CC-Link IE Field communication) or SLMPSEND instructions (during CC-Link IE TSN communication) from the host master station.</p> <p>It is possible to read the Master Unit parameters stored in this product or the service data stored in each connected IO-Link device.</p>
	<ul style="list-style-type: none"> • Event communication 	IO-Link mode	<p>Yes (when the event flag is ON, event codes are read using communication instructions from the host master station)</p> <p>Up to six history records stored in this product (event types: notification, warning, error; event sources: device, master, etc.)</p>
Assignment of IO-Link device process data to this product	Process data automatic allocation/manual setting	IO-Link mode	<p>Process data can either be automatically allocated to this product based on the data size specifications of process input or process output data for each actual IO-Link device that is connected, or (restricted and) allocated to this product by manually setting the number of words used for process input and process output for the IO-Link device on each port.</p> <p>Set the following</p> <ul style="list-style-type: none"> • Process data words auto allocation: Automatically set the allocation size based on the process data length (each maximum length of input and output) of each actual IO-Link device that is connected <p>Or, manually assign with each IO-Link device as follows</p> <ul style="list-style-type: none"> • Process input data words allocation: Set the allocation size (number of words) of process input data for each IO-Link device • Process output data words allocation: Set the allocation size (number of words) of process output data for each IO-Link device <p>Usage:</p> <p>Automatic allocation: Allow IO-Link devices to be allocated at maximum length to this product, without having to determine the process data length and connection port of each IO-Link device.</p> <p>Manual setting: Allow the allocation size to the host master station to be minimized when only a portion of the first half of the process data of an IO-Link device will be used, by not allocating the portion after that.</p>

Category	Function	I/O assignment settings	Product Functions
Connected IO-Link device verification	Device verification	IO-Link mode	<p>This function verifies the compatibility and identity of a connected IO-Link device. When this setting value is written, the model, type name (sum value) and serial number of the actual IO-Link device connected to each port are recorded as storage data in this product. When IO-Link communication is started the next time (including when the power is turned ON for this product, or when I/O assignment is changed to IO-Link mode), this function runs the verification method that was set. If a verification error occurs, it does not perform cyclic communication with the applicable IO-Link device (*1).</p> <p>The following settings are available.</p> <ul style="list-style-type: none"> • Verification/type ID (vendor ID and device ID): Verify the type ID only. • Verification/type ID + type name: Verify the type ID and type name. • Verification/type ID + serial number: Verify the type ID and serial number. • No verification: Verification is not performed. Cyclic communication is performed unconditionally with the applicable IO-Link device (*2). The registered type ID, serial number and type name will also be deleted. <p>Error codes:</p> <ul style="list-style-type: none"> • Type ID mismatch: Verification: FFFE h No verification: FF23 h • Type name mismatch: FFF4 h • Serial number mismatch: FFFC h • Revision ID mismatch: 6001 h <p>*1. If automatic restore is enabled, automatic restore will be performed (setting values will be downloaded from this product to the IO-Link device).</p> <p>*2. However, even if this is set to <i>No verification</i>, only the type ID will be verified when the power (module power supply and I/O power supply) is turned ON if there is already storage data in this product. An error (FF23 h) will occur if the type ID does not match. (If the user changes the connected model after backup, an error is generated to notify the user that storage data for a different type ID remains.) If this is set to <i>No verification</i>, the revision ID (that is, the IO-Link protocol version implemented in the IO-Link device) will not be verified.</p> <p>Usage: This prevents malfunction when an IO-Link device is replaced, by preventing cyclic communication with the IO-Link device when an unexpected IO-Link device is connected or the connection port is different.</p>
I/O operation for communication errors	IO-Link communication and network error handling	<p>IO-Link mode</p> <hr/> <p>SIO *1</p>	<ul style="list-style-type: none"> • Output hold: Hold IO-Link process output data and PNP/NPN output when CC-Link IE Field/TSN is disconnected. Input will be OFF. • Input hold: Hold IO-Link process input data when communication is disconnected with a certain IO-Link device. Output will be OFF. • All hold: Hold IO-Link process input data when communication is disconnected with a certain IO-Link device. Hold process output data and PNP/NPN output when CC-Link IE Field/TSN is disconnected. • Clear (default value): Clear IO-Link process input data to zero when communication is disconnected with a certain IO-Link device. Clear IO-Link process output data to zero when CC-Link IE Field/TSN is disconnected. Clear process input data to zero. Turn PNP/NPN output OFF. <p>Usage: This implements a failsafe by either holding IO-Link process data or clearing it to zero, when there is an IO-Link communication or CC-Link IE Field/TSN communication error.</p> <hr/> <ul style="list-style-type: none"> • Output hold: Hold PNP/NPN output data when CC-Link IE Field/TSN is disconnected. Turn PNP/NPN input data OFF. • Clear: Turn PNP/NPN output data OFF when CC-Link IE Field/TSN is disconnected. <p>Usage: This implements a failsafe by either holding PNP/NPN output data or turning it OFF, when there is a CC-Link IE Field/TSN communication error.</p>

Category	Function	I/O assignment settings	Product Functions
IO-Link communication-related	IO-Link ready flag	IO-Link mode	<p>This function turns ON when all ports are engaged in IO-Link communication and a CC-Link IE Field/TSN has been established with the host master station.</p> <p>This is used as an execution condition for process input, process output and acyclic communication.</p>
	Process data sequence conversion	IO-Link mode	<p>The upper and lower bytes of the input/output process data of the IO-Link device are exchanged to communicate with the host controller.</p> <p>Little endian LSB:default Convert big endian data of IO-Link device to little endian and access. It can be handled as little endian data from the upper network. If the data is an odd number of bytes, the value of the upper byte of the most significant word after word conversion is 0x00.</p> <p>Big endian MSB Access big endian data of IO-Link device as big endian. It can be handled as big endian data from the upper network. If the data is an odd number of bytes, the value of the low byte of the least significant word after word conversion is 0x00.</p> <p>Little endian MSB Convert big endian data of IO-Link device to little endian and access. It can be handled as little endian data from the upper network. If the data is an odd number of bytes, the value of the low byte of the least significant word after word conversion is 0x00.</p> <p>Swap bytes Access the process data of the IO-Link device by swapping the upper and lower bytes in units of one word (two bytes).</p> <ul style="list-style-type: none"> Usage: IO-Link devices that handle upper and lower bytes inversely, and when handling data with an odd number of bytes as word data, there is no need to replace bytes on the host controller side. <p>For details, refer to <i>Word Assignment of Input and Output Process Data for IO-Link Devices in 3-6-1 Example of Cyclic Communication</i> on page 3-39.</p>

Category	Function	I/O assignment settings	Product Functions
I/O synchronization setting	Network synchronization	IO-Link mode or SIO *1	<p>Synchronize IO-Link communication or digital I/O transfer for each port with the CC-Link IE Field/TSN link scan time/communication cycle.</p> <p>If IO-Link communication or digital I/O transfer cannot be synchronized with the link scan time/communication cycle of the host CC-Link IE Field/TSN network, a <i>network synchronization signal error</i> will occur and the STATUS LED on the front of this product will flash green. Synchronization cannot be performed in the following situation.</p> <p>IO-Link cycle time -Process value- (can be confirmed with product setting value number: 51) > Link scan (CC-Link IE Field) or communication cycle (CC-Link IE TSN)</p> <p>During network synchronization, IO-Link communication will not be sent at exactly the same time as host CC-Link IE Field/TSN communication. There will be a delay of 0.56 μs in each port.</p> <p>Usage: Reduce fluctuation in response time between IO-Link devices on all ports and the host master station.</p> <p>Note: If the network synchronization function is enabled, the IO-Link cycle time will fluctuate when the CC-Link IE Field/TSN link scan time/communication cycle fluctuates. It is therefore recommended (especially for CC-Link IE Field) to set the link scan time to either <i>Constant link scan</i> or <i>Sequence scan synchronization</i> and use the CPU module for constant scanning.</p>
	I/O synchronization	IO-Link mode or SIO *1	<p>Use IO-Link communication or digital I/O transfer to maintain synchronization for IO-Link devices on multiple ports.</p> <p>Usage example:</p> <ul style="list-style-type: none"> • Sample data from multiple sensors at the same time. • Control multiple motorized actuators at the same time.
Time information function	Network time	IO-Link mode or SIO *1	<p>For CC-Link IE TSN, the network time (setting value number: M65) is displayed on this product, which takes the time zone -UTC- (setting value number: M6) into consideration. The internal timer of this product can also be synchronized with the network time (using the I/O synchronization (setting value number: M21) setting).</p> <p>For CC-Link IE Field, this product obtains time information only once during startup and then updates it.</p>
	Synchronization establishment flag	IO-Link mode or SIO *1	<p>This flag turns ON when the internal timer of this product is synchronized with the network time (within +/-20 μs).</p>
	Allocation of time information to process input data	IO-Link mode or SIO *1	<p>Time information and parity information can be added to process input data. This is set using time stamp (setting value number: M44).</p>
	Storage of time read from IO-Link device setting value	IO-Link mode	<p>The time can be read from the IO-Link device setting value, stored in this product, and then read from the host PLC.</p>

Category	Function	I/O assignment settings	Product Functions
IO-Link device setting value backup/restore (from/to this product)	Manual backup/restore of settings	IO-Link mode	<p>This function manually backs up and restores parameters (stored setting values) stored in IO-Link devices.</p> <p>Select one of the following. The process can be executed either by operating the controls on the front of this product, or by writing setting values from the host master station.</p> <ul style="list-style-type: none"> • Restore: Download (<i>restore</i>) storage data stored in this product to its IO-Link device. • Backup: Upload (<i>backup</i>) parameters from the IO-Link device to this product. • Delete: Delete all IO-Link device storage data stored in this product. <p>Note 1. This function may be used only if the connected IO-Link device supports the data storage function.</p> <p>Note 2. Error code <i>FFFF h</i> will occur if the vendor ID or device ID of the restore target IO-Link device differs from the storage data from this product, when restoring.</p> <p>Usage: This allows parameters from the old IO-Link device to be carried over from this product, when replacing an IO-Link device with a new device.</p>
	Automatic device parameter backup	IO-Link mode	<p>This function automatically backs up and restores parameters (stored setting values) stored in IO-Link devices.</p> <p>Note This function may be used only if the connected IO-Link device supports the data storage function.</p> <p>Select from the following.</p> <ul style="list-style-type: none"> • Restore: When IO-Link communication starts, automatically download (<i>restore</i>) the storage data in this product to the IO-Link device, if the IO-Link device storage data in this product does not match the parameters in the connected IO-Link device (*1). <p>*1. The Master Unit parameters in this product will be overwritten when IO-Link communication is next started, even if the parameters in the IO-Link device are changed during IO-Link communication.</p> <ul style="list-style-type: none"> • Backup: Upload (<i>backup</i>) parameters from the IO-Link device to this product, if parameters in the IO-Link device are changed during IO-Link communication. • Restore and backup: Automatically restore or backup so that storage data in this product always matches parameters in the IO-Link device. • None: Restore and backup are not automatically performed. <p>Note Error code <i>FFFF h</i> will occur if the vendor ID or device ID of the restore target IO-Link device differs from the storage data from this product, when automatically restoring.</p> <p>Usage: This allows parameters from the old IO-Link device to be carried over from this product, when replacing an IO-Link device with a new device.</p>

Category	Function	I/O assignment settings	Product Functions
Input related	Input hold time	SIO *1	<p>This function holds ON for the specified time once the input signal turns ON.</p> <p>Usage: This ensures that even SIO input signals with a short ON time are transmitted to the host master station. The hold time can be increased for situations where the sensor ON time is short and the host master station cannot reliably pick up that the sensor is ON.</p>
	Input filter time	SIO *1	<p>This function sets a filter to eliminate input signal noise.</p> <p>Usage: This can eliminate erroneous input caused by noise or erroneous sensor detection on workpiece edges, etc.</p>
	Encoder input (high-speed counter function)	SIO *1	<p>The high-speed counter function can be used by connecting an open collector output incremental encoder as an SIO device to this product.</p> <p>Assign phase A and phase B (and phase Z, if required) to each port of the SIO mode PNP input or NPN input. This assignment is specified using the Master Unit parameter <i>M18. Pulse input</i>.</p> <p>The port numbers assigned to phase A, phase B, and phase Z must be in continuous order (if phase A is n, phase B must be n+1 and phase Z must be n+2).</p> <ul style="list-style-type: none"> • When using phase A and phase B as input (regardless of whether phase Z is used) The count is multiplied by four, and the count value will be 13 bits per rotation with 32 bits for the rotation count. The count maximum frequency is 250 kpps. • Count values of one rotation or lower will fit in one word (two bytes) on the process input data side of the port assigned to phase A. • 32 bits for the rotation count will fit in two words (four bytes) from the second word (+4) on the process input data side of the port assigned to phase A. • When using only phase A as input The count is multiplied by two and the count value is 45 bits, and will fit in three words on the process input data side (however, only up to 32 bits will be shown on the display of this product). <p>In any of the cases above, the three-word (six-byte) count current value will be cleared when <i>Reset encoder counter</i> (output byte address +2, bit address 6) is switched from 0 (OFF) to 1 (ON).</p> <p>Note that the count current value mentioned above is the value when the cyclic communication data of the host network is updated.</p>

Category	Function	I/O assignment settings	Product Functions
Status monitoring-related	Number of IO-Link communication errors	IO-Link mode	This counts the number of IO-Link communication errors on each port. Usage: This can be used when diagnosing IO-Link communication quality based on the number of communication errors.
	I/O power supply flag	IO-Link mode	This function monitors whether the I/O power supply is on or off. Usage: This monitors whether the product I/O power supply is on or off.
	I/O power supply voltage	IO-Link mode	This function can be used to check the voltage supplied to the I/O power supply. (unit: 0.1 V) Usage: This monitors the voltage of the product I/O power supply.
	Output over-current flag	SIO *1	This function turns RX15 (hexadecimal value) ON when there is a PNP/NPN output overcurrent. Usage: An output overcurrent occurs when this flag is ON, so this can be used to discover issues such as a short circuit in the load.
	Total operation hours of IO-Link Master Unit	IO-Link mode or SIO *1	This function can be used to check the cumulative operating time since this product was first turned ON. (unit: hours) Usage: This can be used for product maintenance.
	Display drive time	IO-Link mode or SIO *1	This function can be used to check the cumulative operating time since the front display on this product was turned ON. (unit: hours) Usage: This can be used for product maintenance.
	Internal temperature	IO-Link mode or SIO *1	This function can be used to check the internal temperature of this product. (unit: 0.1°C) Usage: This can be used for product maintenance.

*1. SIO: Either PNP input mode, NPN input mode, PNP output mode or NPN output mode



Front Panel Controls

This section describes how to use the controls on the front panel of this product.

5-1	Front Panel Controls	5-2
5-1-1	Operating Window Overview	5-2
5-1-2	Process Data Display Window	5-3
5-1-3	Master Unit Parameters Window.....	5-5
5-1-4	Device Setting Value Window	5-6
5-1-5	Event/Error Display Window.....	5-8



5-1 Front Panel Controls

5-1-1 Operating Window Overview

The front panel controls on this product can be used to control the following windows.

- Process data display window
- Master Unit Parameters Window
- Device setting value window
- Event/Error Display Window

Windows are controlled using the following buttons.

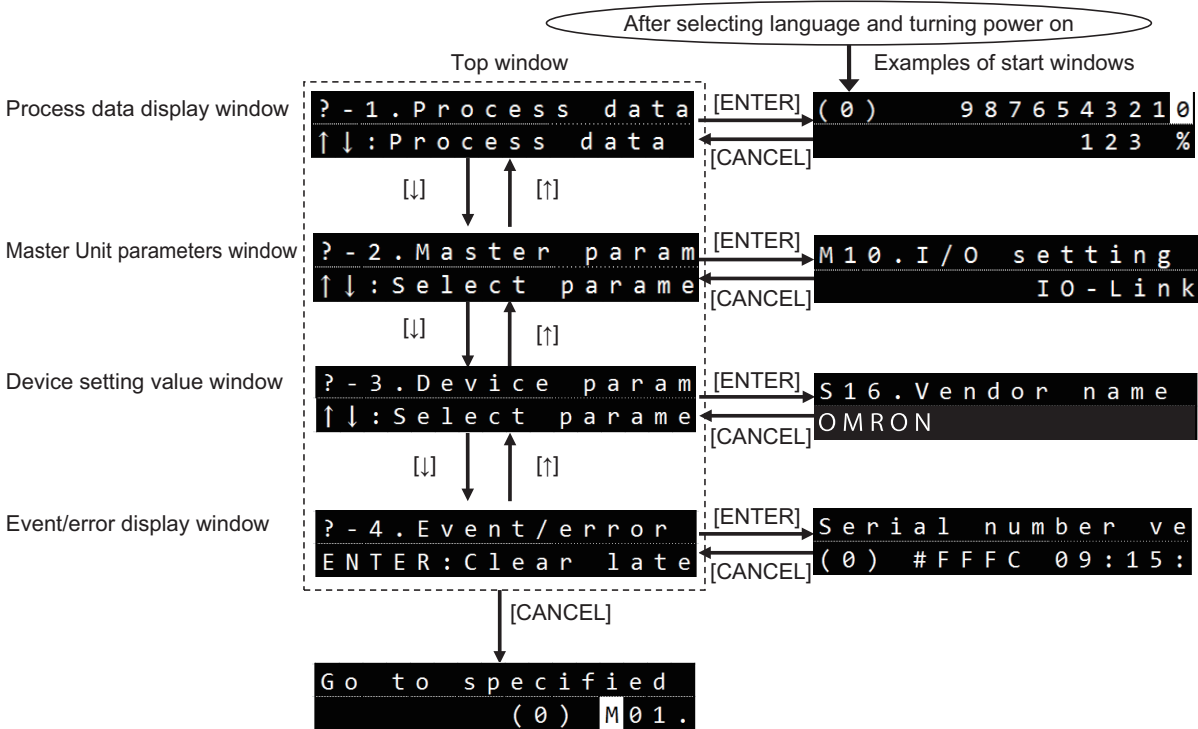
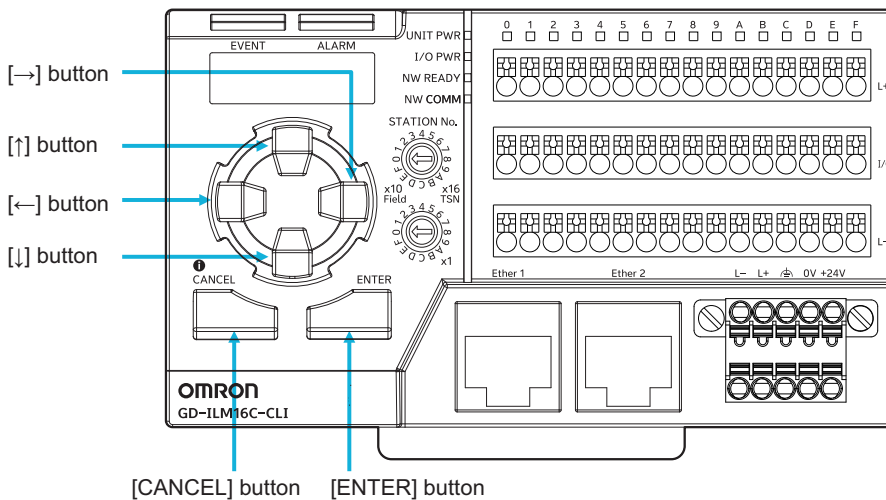

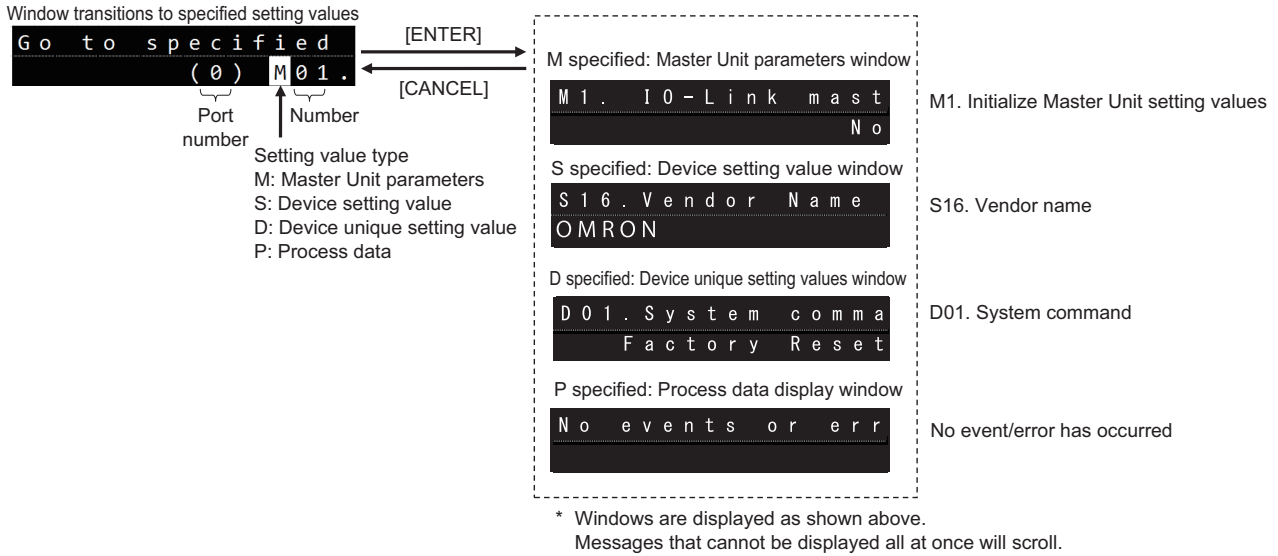

5-1-2 Process Data Display Window

I/O assignment or process data is displayed.

Title window:

Menu number



Window transition:

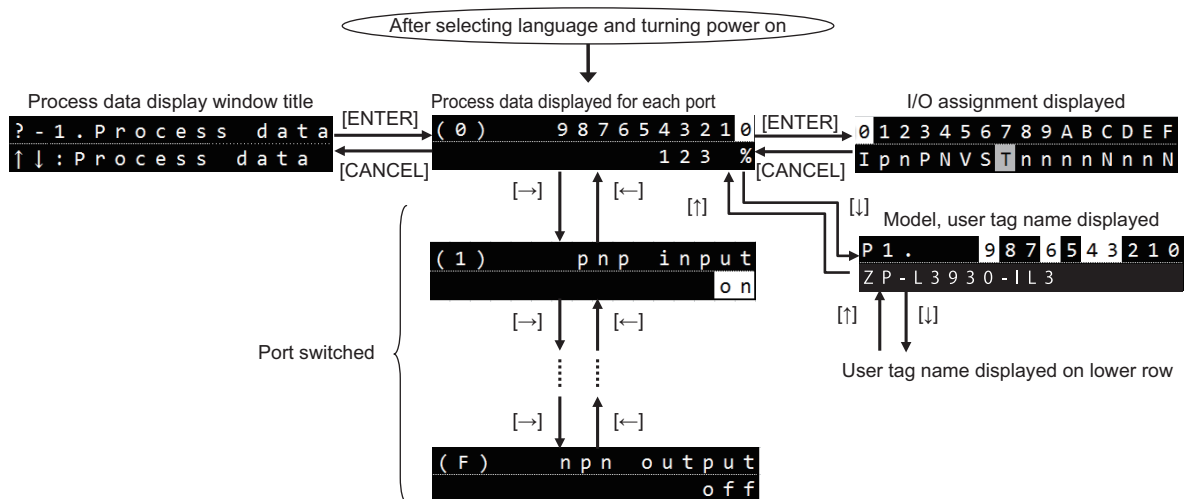

I/O Assignment Display

This window shows the I/O assignment settings (and device verification settings) for each port, as well as any current IO-Link communication errors or verification errors.

0	1	2	3	4	5	6	7	8	9	A	B	C	D	E	F	← Port number	
I	p	n	P	N	V	S	T	n	n	n	n	n	n	n	n	n	← I/O function assignment settings

The I/O assignment settings and device verification settings for each port are displayed using the following codes beneath the port number.

I: IO-Link mode (no verification)

Note will blink when an IO-Link device is not connected or there is a communication error.

V: IO-Link mode (verification/type ID)

S: IO-Link mode (verification/serial number)

T: IO-Link mode (verification/type name)

p: PNP input mode

n: NPN input mode

P: PNP output mode

N: NPN output mode

— : Unused

In IO-Link mode, the IO-Link device connection status, communication status and device verification status are indicated by blinking the following characters.

I blinking: An IO-Link device is not connected or there is a communication error.

V blinking: An IO-Link device with a different type ID (vendor ID or device ID) is connected.

S blinking: An IO-Link device with a different type ID (vendor ID or device ID) or serial number is connected.

T blinking: An IO-Link device with a different type ID (vendor ID or device ID) or type name is connected.

If I, V, S or T are shown as a lowercase letter (i, v, s or t), it indicates that the process input data of the IO-Link device is invalid.

Process Data Display

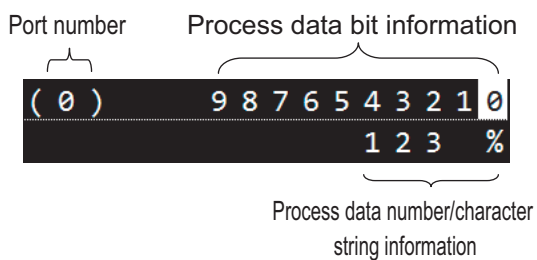

The window shown above will be the default window once a language has been selected and the power is turned ON.

The following is displayed on the upper row.

Left: Port number (0 - F)

Right: Process data bit information (up to 10 bits)

Pressing the ↑ and ↓ keys switches the lower row as follows.

- Process input data (hexadecimal)
- Process output data (hexadecimal)

Example:

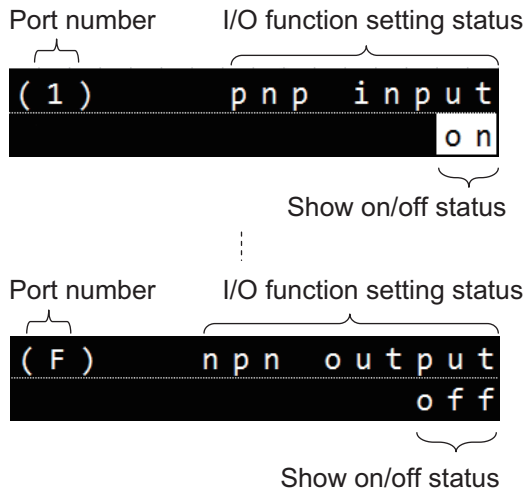

Process data switch/product type/user tag name display

Example:

Process data input number (starting from P1.), process data output number (starting from Q1.)



The following is displayed on the upper row.

Left: P□ (process input data number), Q□ (process output data number)

Note Numbers are assigned continuously including P and Q.

The display will switch to “(0)” for approximately one second after transitioning to this menu. If IO-Link device process data for port x was being displayed, “(x)” will be displayed.

Right: Process data bit information (up to 10 bits)

The product type or user tag name will be displayed in the lower row.

5-1-3 Master Unit Parameters Window

The controls on the front of this product can be used to change and monitor the Master Unit parameters (user settings) of this product.

Refer to 6-4-3 *Master Unit Parameter List with Product Front Panel Operation* on page 6-38 for Master Unit parameter list with product front panel operations.

Title window:



Window transition:

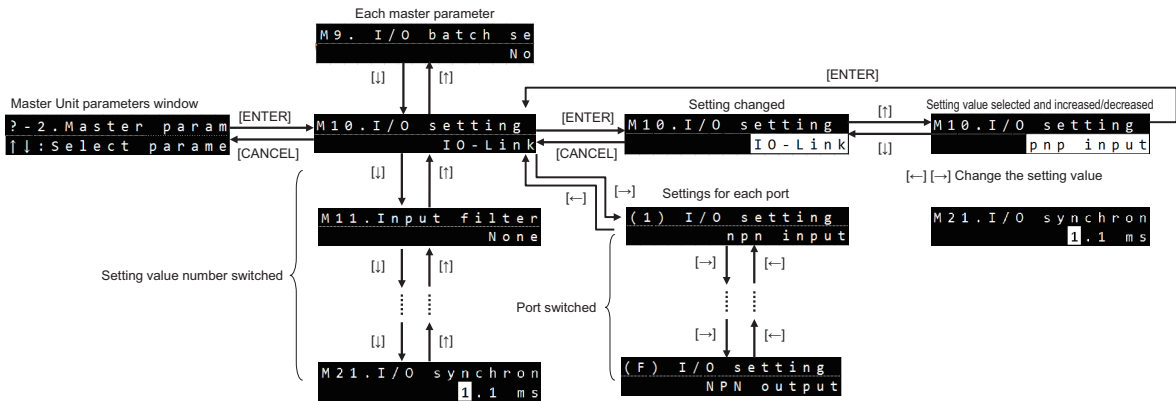

Note M5. Language will be displayed the first time that power is turned ON. Refer to 2-4-2 Language on page 2-14 for further information.

Description of each window:

The following is displayed on the upper row.

Left: M□: Setting value number of this product

Right: Setting name

The setting value is displayed on the lower row.

Example:

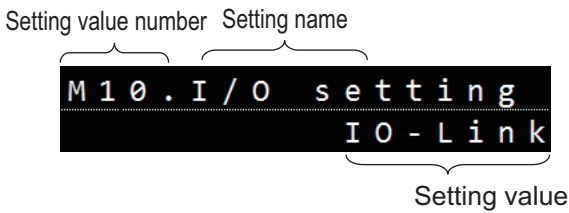

Settings for each port

Example:

Port number display (will switch to port number display when the port is switched or five seconds have passed).

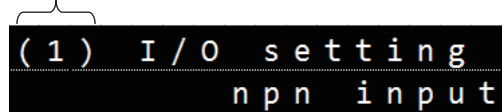

5-1-4 Device Setting Value Window

Device information from each IO-Link device can be confirmed and any given index number can be written from this product.

Title window:



(Not displayed if an IO-Link device is not connected)

Window transition:

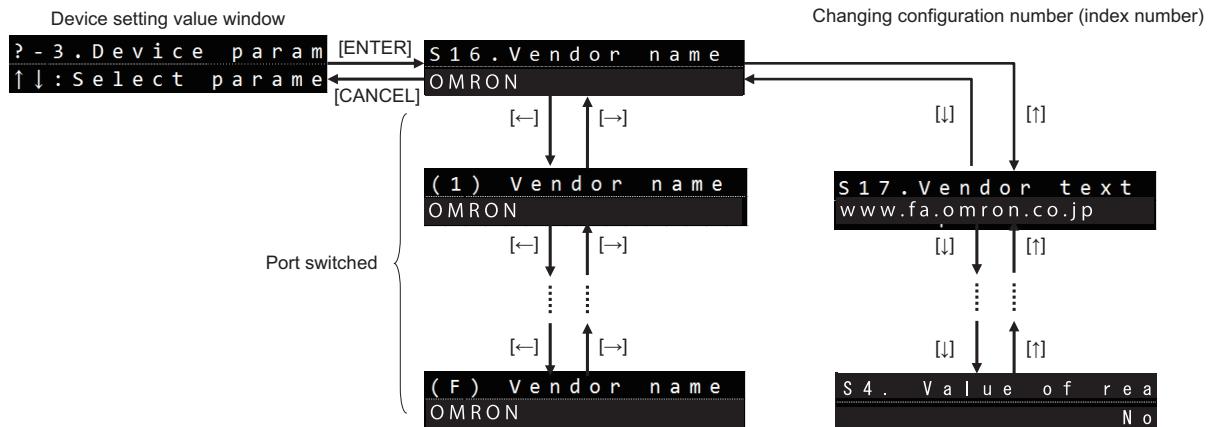

Description of each window:

The following is displayed on the upper row.

Left: S□ (IO-Link device index number)

Right: Setting name

The setting value is displayed on the lower row.

Example:

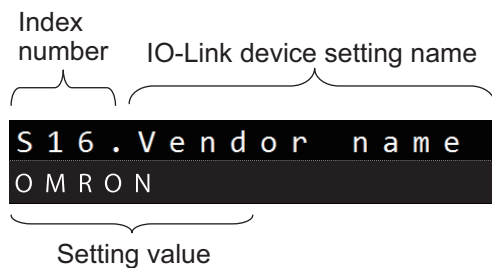

Device Information Confirmation

The following standard index device information can be read.

● Standard Index

Setting (upper row)	Description	Read-only: R, Read/write: R/W
S16. Vendor name	Read the value of index 16 (vendor name) and display it as a character string.	R
S17. Vendor text	Read the value of index 17 (vendor text) and display it as a character string.	R
S18. Product type	Read the value of index 18 (product name) and display it as a character string.	R
S19. Product ID	Read the value of index 19 (product ID) and display it as a character string.	R
S20. Product function	Read the value of index 20 (product text) and display it as a character string.	R
S21. Serial number	Read the value of index 21 (serial number) and display it as a character string.	R

Setting (upper row)	Description	Read-only: R, Read/write: R/W
S22. Hardware revision	Read the value of index 22 (hardware revision) and display it as a character string.	R
S23. Firmware revision	Read the value of index 23 (firmware revision) and display it as a character string.	R
S24. User tag name	Read the value of index 24 (application specific tag) and display it as a character string.	R/W

Setting Value Manual Setting (Specify an Index Number)

As shown below, an index number can be specified and the setting value manually read.

Setting (upper row)	Description	Read-only: R, Read/write: R/W
S1. Index to read	Specify the index number directly for use when accessing the device (access is restricted in accordance with IO-Link rules for index number 3).	R/W
S2. Subindex	Next, specify the subindex number directly.	R/W
S3. Type of index	Specify the setting value data type of the index to access. Select either signed integer, unsigned integer, character string or hexadecimal floating point number (read-only).	R/W
S4. Value of read	The data that was read is displayed. "-----" will be displayed if a read error occurs. Press the ENTER button to edit the setting value. Press the ENTER button again to write that setting value.	R/W

5-1-5 Event/Error Display Window

The event code/event name for the latest and six most recent events can be read from the IO-Link device, along with the error code/error message of any current errors.

Title window:

```
? - 4 . Event / error
ENTER : Clear late
```

Window transition:

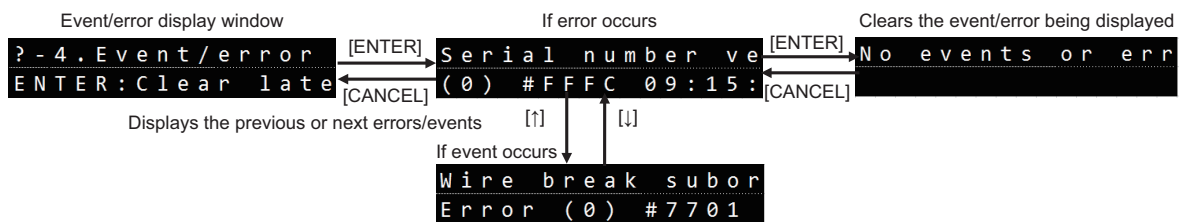

If error occurs
 Example:

```

Serial number ve ← Error message
( 0 ) # F F F C 0 9 : 1 5 :
  ↑           ↑
  Port number Error code

```

The error message is displayed on the upper row.

The following is displayed on the lower row.

Left: Port number (0 - F)

Right: Error code (#) and error time (example: #FFFC 09:00:59 20/06/24)

Note The index number and subindex number that caused the error will be displayed after the error code and before the error time on the row beneath the error message *Invalid index number*, as shown below.

Example: Index=0064-01 (index number: 0064, subindex number: 01)

If event occurs

Example:

```

Wire break subor ← Event name
Error ( 0 ) # 7 7 0 1
  ↑           ↑           ↑
  Event type Port number Event code

```

The event name is displayed on the upper row.

The following is displayed on the lower row.

Left: Event type (notification, error or warning)

Center: Port number (0 - F)

Right: Event code (#) and event time (example: #7701 09:00:59 20/06/24)

Clears the event/error being displayed

The following is an example where no errors or events have occurred.

```

No events or err

```

A message indicating no errors/events is displayed on the upper row.

6

Specifications

This section describes the specifications of this product.

6-1	Specifications	6-2
6-2	Data Processing Time	6-5
6-2-1	Process Data Response Time Calculation	6-5
6-2-2	IO-Link Device Setting Value Access Time via IO-Link ISDU Commu- nication	6-9
6-3	Dimensions	6-10
6-4	List of Product Master Unit Parameters	6-12
6-4-1	User Settings	6-12
6-4-2	Data for Access from PLC	6-28
6-4-3	Master Unit Parameter List with Product Front Panel Operation	6-38

6-1 Specifications

General Specifications

Item		GD-ILM16C-CLI	GD-ILM16E-CLI
Number of ports		16	
Power supply voltage		24 VDC +/-15% (SELV and LIM power supplies, or UL 1310 Class 2 power supplies)	
Current consumption (Only Master Unit)		220 mA max.	
Maximum current of the port		0.2 A or less per 1 port, 2.5 A or less per 16 ports	
Maximum power current		8 A (Total of unit power supply and I/O power supply)	
Insulation resistance		20 MΩ or more (between external power supply and unit power supply at 500 VDC)	
Connectors	Field network	2x RJ45 connectors	
	Power supply	Spring-clamp terminal block, 5-pole, 2-row	
	Input/output	3x 16-channel spring-clamp terminal blocks	16x e-CON sockets, 4 poles
Indicators		POWER LED (blue green), EVENT LED (yellow), ALARM LED (red), I/O LED (orange)	
Display		OLED (Display language: English, Japanese, Simplified Chinese, Traditional Chinese, Korean, French, Spanish, German, Portuguese, Italian)	
Field network		<ul style="list-style-type: none"> • CC-Link IE Field • CC-Link IE TSN (Switch in settings)	
I/O assignment		Switchable in the following 6 modes by setting for each port: <ul style="list-style-type: none"> • Unused (default) • IO-Link communication mode • SIO (PNP input) mode • SIO (NPN input) mode • SIO (PNP output) mode • SIO (NPN output) mode 	
IO-Link communication specifications	IO-Link revision	1.1	
	Communication speed	COM1 (4800bps) / COM2 (38400bps) / COM3 (230.4kbps)	
	Physical layer	IO-Link-compliant	
	Minimum cycle time	0.3 ms	
	Data	Periodic: Process data, Status Aperiodic: Devices data, Event	
Input Specifications	Rated input voltage	24 VDC +/-20% (SELV and LIM power supplies, or UL 1310 Class 2 power supplies) *1	
	Voltage and current at ON	PNP: 15 VDC or more, 5.5 mA or more NPN: Power supply voltage-13 VDC or less, 3.0 mA or more	
	Voltage and current at OFF	PNP: 10 VDC or less, 2.0 mA or less NPN: Power supply voltage-8 VDC or more, 2.0 mA or less	
	Input resistance	PNP: 5.5 mA rated current circuit load, NPN: 4.7 kΩ	
	Input filter time	0 ms (default), 0.1 ms, 1 ms, 5 ms, 10 ms, 20 ms	

Item		GD-ILM16C-CLI	GD-ILM16E-CLI
Output Specifications	Rated load voltage	10.8 to 26.4 VDC (SELV and LIM power supplies, or UL 1310 Class 2 power supplies)* ¹	
	Maximum output load current	0.2 A per 1 point, 2.5 A per 16 port	
	Overcurrent protection current	Current limiting (0.5A) by Overcurrent protection function	
	OFF output leakage current	PNP: 0.1 mA or less NPN: 0.2 mA or less	
	Residual voltage	PNP: 1.8 V or less NPN: 1.6 V or less	
	Output response time	0.1 ms or less	
Environmental resistance	Operating/Storage temperature	Operating: 0 to 55°C, Storage: -25 to +75°C (no freezing or condensation)	
	Operating/Storage humidity	Operating/Storage: 5 to 95% RH (no condensation)	
	Vibration resistance	IEC 61131-2 compliant Vibration frequency: 5 to 8.4 Hz, single amplitude: 3.5 mm Vibration frequency: 8.4 to 150 Hz, acceleration: 10m/s ² (1.0 G) Number of sweeps: 10 times each in 3 directions along X, Y, and Z axes	
	Shock resistance	IEC 61131-2 compliant Peak acceleration: 150m/s ² (15 G), 3 times each in 3 directions along X, Y, and Z axes (total of 18 times)	
	Operating environment	No corrosive gas	
	Operating altitude	0 to 2,000 m	
	Installation location	Indoor use	
	Degree of protection	IP20	
Overvoltage category	II or less		
Pollution degree	2 or less		
Equipment class	Class I		
Material	Case: PC, keys/DIN rail mounting hook: POM, terminal block: PA		
Weight	Approx. 195 g (including terminal blocks, when not wired)		
Included accessories	Instruction manual, compliance sheet, power terminal block, 2x RJ45 connector protective cap (attached to unit), 3x device terminal block	Instruction manual, compliance sheet, power terminal block, 2x RJ45 connector protective cap (attached to unit)	

*1. Use a Class 2 power supply or a power supply compliant with SELV (Safety Extra-Low Voltage) circuit and LIM (Limited Energy Circuit) circuit standards.

Host Network Communication Specifications

● CC-Link IE Field Communication Specifications

Item	Specification
	GD-ILM16□-CLI
Field network communication protocol	CC-Link IE Field
Station type	Remote device station or intelligent device station
Transmission speed	1Gbps
Total cable extension	PLC to this product (IO-Link Master Unit): 100 m This product (IO-Link Master Unit) to IO-Link device: 20 m

Item	Specification
	GD-ILM16□-CLI
Station number setting	1 to 120
Internal response time	0.6 ms or less

● CC-Link IE TSN Communication Specifications

Item	Specification
	GD-ILM16□-CLI
Field network communication protocol	CC-Link IE TSN
Station type	Remote station
Transmission speed	1 Gbps or 100 Mbps ^{*1}
Total cable extension	PLC to this product (IO-Link Master Unit): 100 m This product (IO-Link Master Unit) to IO-Link device: 20 m
Station number setting	1 to 254
Internal response time	0.6 ms or less
Certification class	Class B or Class A (switchable)

*1. This is specified using the Master Unit parameter *M83. IE TSN Class setting*. Note that 100 Mbps is supported only for certification class A.

6-2 Data Processing Time

6-2-1 Process Data Response Time Calculation

The process data response time from the host master station CC-Link IE Field or CC-Link IE TSN and through IO-Link is indicated as follows.

For CC-Link IE Field

● When CC-Link IE Field and IO-Link Are Not Synchronized

- Process input data

$(\text{IO-Link cycle time}) \times (1 \text{ to } 2) + (\text{CC-Link IE Field link scan time}) \times (1 \text{ to } 2) + (\text{PLC CPU module scan time}) \times (1 \text{ to } 2)$

Example:

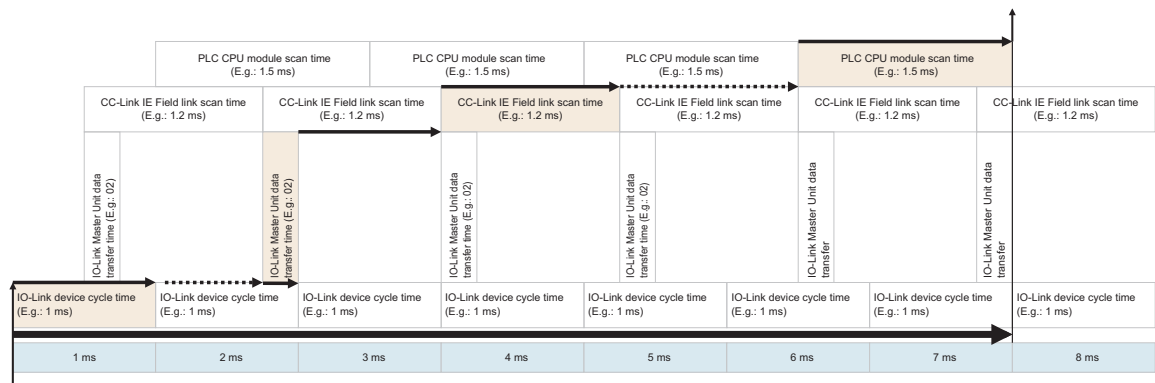

- Process output data

$(\text{PLC CPU module scan time}) + (\text{CC-Link IE Field link scan time}) \times (1 \text{ to } 2) + (\text{IO-Link cycle time}) \times (1 \text{ to } 2)$

Example:

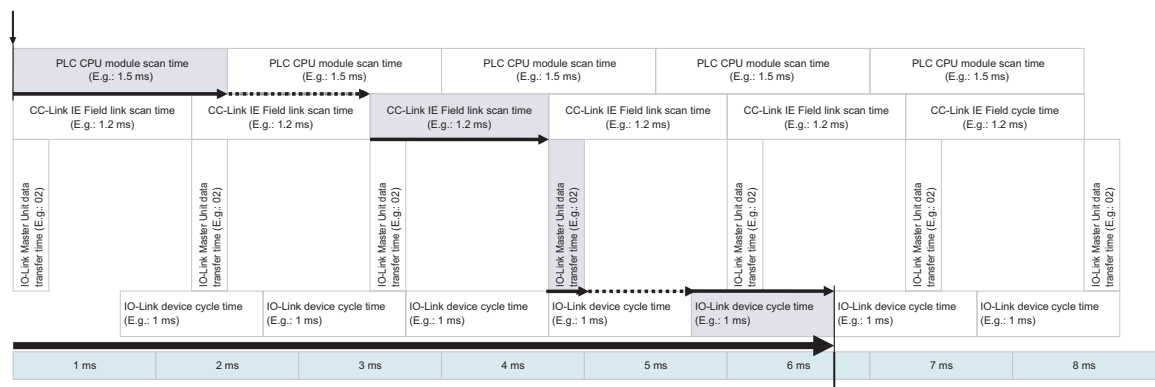

● When CC-Link IE Field and IO-Link Are Synchronized (Using Network Synchronization Function)

$(\text{PLC CPU module scan time}) + (\text{CC-Link IE Field link scan time} = \text{IO-Link cycle time}) \times 3$

Example: CC-Link IE Field link scan time as sequence scan synchronization, and sequence scan as constant scan

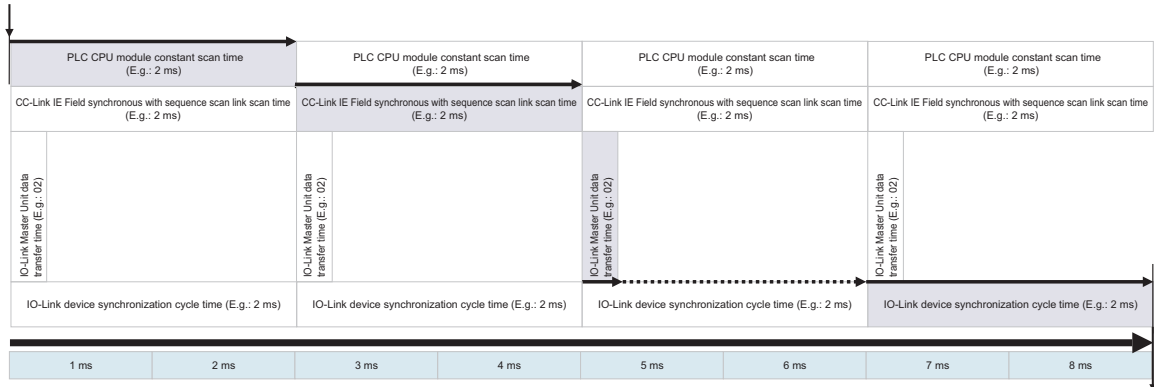

For CC-Link IE TSN

● When CC-Link IE TSN and IO-Link Are Not Synchronized

- Process input data

$(\text{IO-Link cycle time}) \times (1 \text{ to } 2) + (\text{CC-Link IE TSN communication cycle}) \times (1 \text{ to } 2) + (\text{PLC CPU module scan time}) \times (1 \text{ to } 2)$

Example:

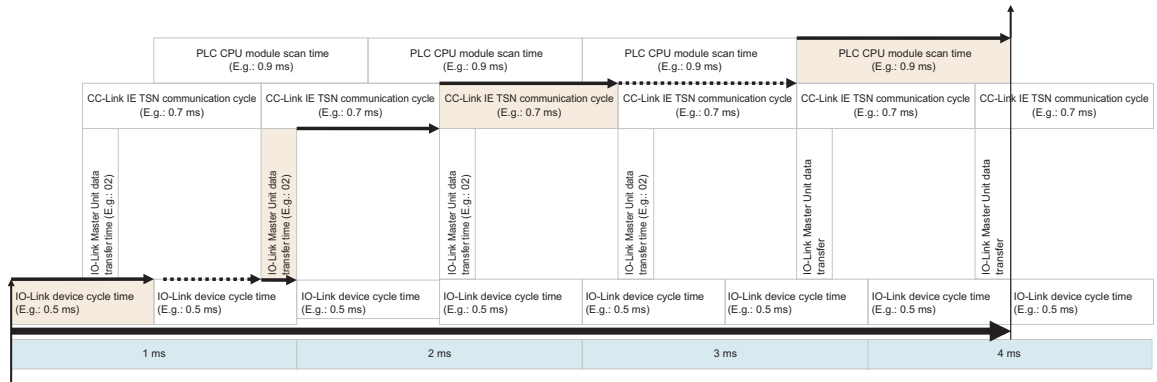

- Process output data

$(\text{PLC CPU module scan time}) + (\text{CC-Link IE TSN communication cycle}) \times (1 \text{ to } 2) + (\text{IO-Link cycle time}) \times (1 \text{ to } 2)$

Example:

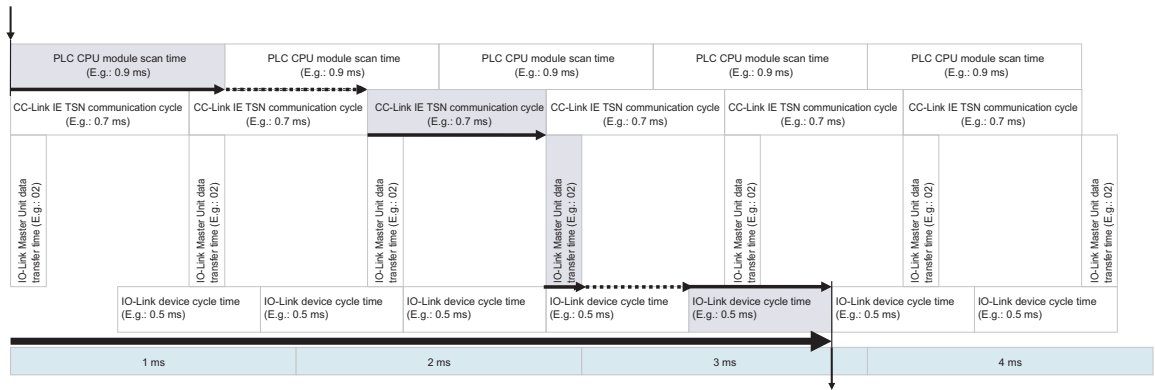

● **When CC-Link IE TSN and IO-Link Are Synchronized (Using Network Synchronization Function)**

(PLC CPU module scan time) + (CC-Link IE TSN communication cycle = IO-Link cycle time) × (3 to 4)

Example:

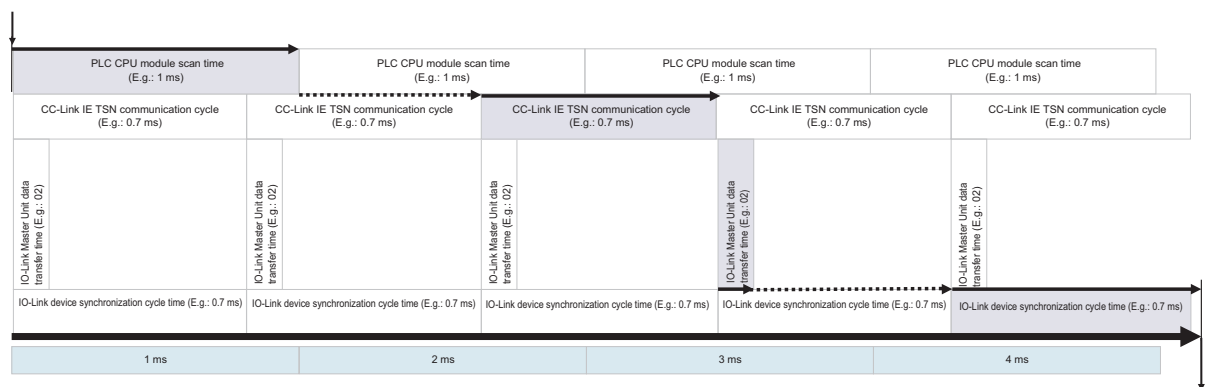

Note There is no sequence scan synchronization for CC-Link IE TSN.

IO-Link Communication Response Time

The minimum cycle time for IO-Link devices is defined by individual device.

- Minimum cycle time of “0”: The fastest cycle time supported by this product will be used.
- Minimum cycle time specified: This product will communicate with the IO-Link device at the specified cycle time.

The actual cycle time can be confirmed in the *Master Unit parameters (M51. IO-Link cycle time - Process value-)* for this product.

Note This product performs IO-Link communication using hardware logic rather than software, so the fastest time is 0.3 ms.

The cycle time can be specified on this product. To do so, set the *Master Unit parameter M21. I/O synchronization* on this product. However, it cannot be set faster than the minimum cycle time of the IO-Link device.

Fastest Cycle Time for IO-Link

Conditions: Process input data bytes: 2, process output data bytes: 0, bytes read or written through acyclic communication (ISDU communication): 1

Minimum 0.35 ms: Add the command, checksum and reserve bytes, and then multiply by 0.05 ms.

COM3: 0.4 ms (time under 0.1 ms rounded up)

COM2: 2.4 ms

COM1: 19.2 ms

Synchronization Function between IO-Link Communication and Digital I/O

For CC-Link IE TSN, if the Master Unit parameter *M21. I/O synchronization* is set to *Synchronous timer 0.8/1.6/3.2/6.4 ms* in this product, the internal timer of this product will be used to synchronize IO-Link communication or digital I/O transfer between multiple ports set to the same setting value at a cycle of 0.8/1.6/3.2/6.4 ms. (this can also be confirmed in Master Unit parameter *M51. IO-Link cycle time -Process value-*)

However, in order to suppress noise generated by the communication signal, IO-Link communication delays each port 0.56 μ s instead of sending at the exact same time.

Network Synchronization Function

If the Master Unit parameter *M21. I/O synchronization* is set to *Network synchronization* in this product, IO-Link communication or digital I/O transfer for the specified port will be synchronized with the link scan time/communication cycle of the host network (CC-Link IE Field/TSN).

Note The IO-Link cycle time will fluctuate according to the communication cycle of the host network. If using CC-Link IE Field communication, it is therefore recommended to set *Synchronous with sequence scan* and use the CPU module in constant scan.

CC-Link IE Field Link Scan Time or CC-Link IE TSN Communication Cycle Interval Settings

● For CC-Link IE Field

Either *Normal mode* or *High-speed mode* can be selected for the *Communication mode* module parameter on the CC-Link IE Field Master Unit.

The link scan time depends on the number of slave units and the number of refresh data words.

The fastest link scan time is approximately 0.7 ms *normal* or 0.3 ms *high-speed*.

Response time fluctuation can be further minimized by synchronizing with the sequence scan (select *Synchronous with sequence scan* for *Link scan mode*).

Response time fluctuation can be further minimized by setting the CPU module to *Constant scan*.

● For CC-Link IE TSN

The communication cycle for CC-Link IE TSN depends on the number of slave units, the number of refresh data words and the switching hub delay. The minimum is 125 μ s.

Internal Data Transfer Processing Time for This Product

IO-Link device process input data is first rearranged through software in this product, and then transferred to the CC-Link IE Field/TSN processing chip.

The processing time depends on the number of process data bytes for the IO-Link devices on all ports. It will be transferred at a speed of approximately 0.1 to 0.4 ms.

6-2-2 IO-Link Device Setting Value Access Time via IO-Link ISDU Communication

When IO-Link ISDU communication is used to write IO-Link device setting values, the time required for writing will depend on the IO-Link cycle time and the data length of the IO-Link device setting value to write.

Although this does not include the delay time for transient transmission itself, this delay will not have much of an effect.

Expect data writing to take 10 ms at the fastest IO-Link cycle time.

This time may exceed 100 ms if the data length is long or the IO-Link cycle time is slow.

Examples are shown below.

Item	Read example			Write example		
	40	80	1000	41	80	1000
Index number to access *1	40	80	1000	41	80	1000
Subindex number to access *2	0	1	0	0	1	0
Number of data bytes to access *3	4 bytes	4 bytes	8 bytes	2 bytes	4 bytes	16 bytes
Busy count until IO-Link device returns response	1	1	1	1	1	1
Actual cycle time for IO-Link communication	0.6 ms	1 ms	2 ms	0.6 ms	1 ms	2 ms
Number of bytes for on-request data for IO-Link device (1, 2, 8, 32)	1 byte	1 byte	1 byte	1 byte	1 byte	1 byte
Number of command and checksum bytes	5 bytes	6 bytes	7 bytes	5 bytes	6 bytes	7 bytes
Number of cycles required for access	10	11	16	8	11	25
Resulting time until access is complete	6 ms	11 ms	32 ms	4.8 ms	11 ms	50 ms

*1. Index numbers 256 and above are specified as three bytes regardless of the subindex number.

*2. This will be specified as two bytes if the index number is 255 or lower and the subindex number is not 0.

*3. If the number of command and checksum bytes is 16 or higher (including the specified number of index number bytes described above and the number of bytes to write) when written, the number of bytes will be increased by one to specify the number of bytes. When reading, if the number of bytes to read is 14 or higher, the number of bytes will be increased by one to specify the number of bytes.

6-3 Dimensions

GD-ILM16C-CLI

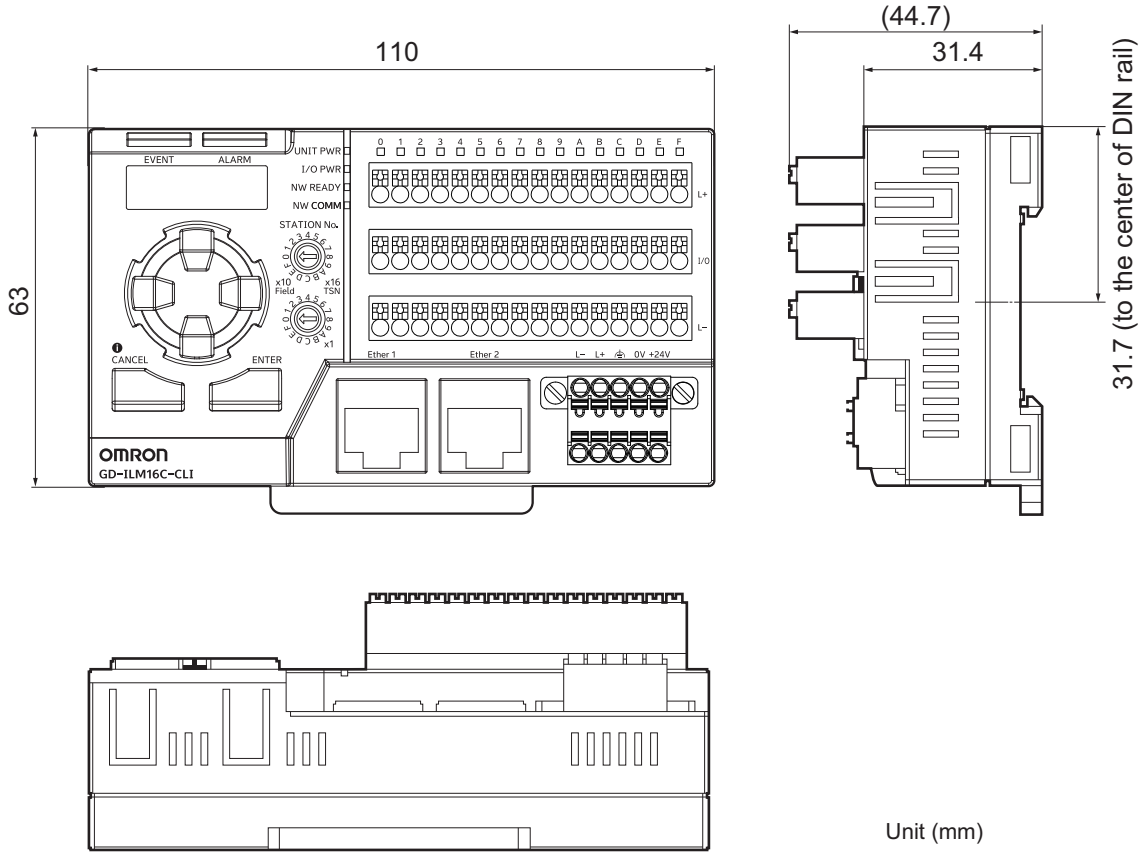

Unit (mm)

GD-ILM16E-CL1

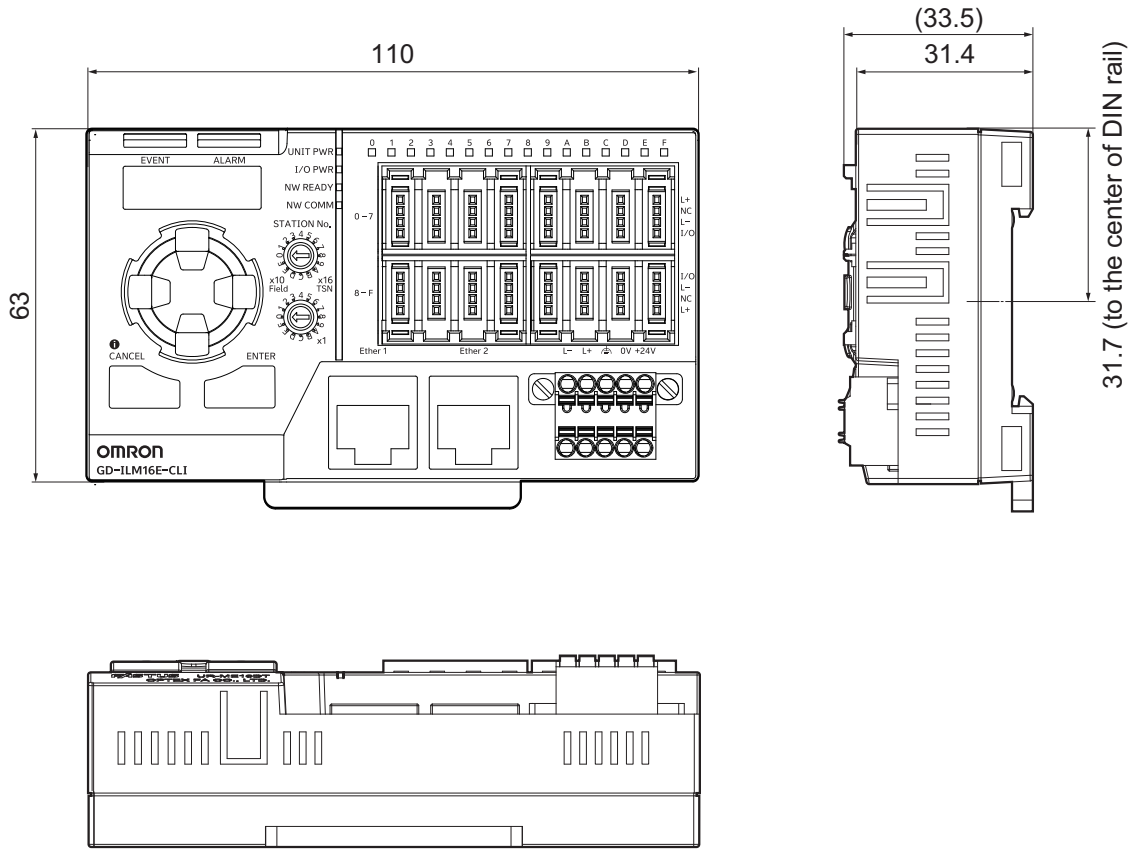

6-4 List of Product Master Unit Parameters

A list of product Master Unit parameters is displayed. The Master Unit parameters are classified as below.

- User settings
- Data for Access from PLC

Note that this product's Master Unit parameters are handled as little endian (beginning from the lower byte).

Note In the right column of the table below, items that can be accessed via product front panel operation or communication from the host master station are marked with ●.

6-4-1 User Settings

Master Unit parameter numbers DEC (HEX)	Target number 0 to 15: corresponds to channel number, 0: This product	Data Name	R/W	Format	Length in bytes	Value	Front panel controls (Master Unit parameter numbers)	Communication from host master station	Firmware version
1 (1 h)	0	Master Unit parameters reset	RW	UINT	1	0 (default value)	None	● (M1)	●
						1	Initialize I/O assignment for all ports in IO-Link mode. (Storage data, display language, network type, and network No. will not be initialized)		
						2	As above, initialize I/O assignment for all ports in PNP input mode.		
						3	As above, initialize I/O assignment for all ports in NPN input mode.		
						4	As above, initialize I/O assignment for all ports in PNP output mode.		
						5	As above, initialize I/O assignment for all ports in NPN output mode.		
						6	As above, initialize I/O assignment for all ports as unused.		
						7	Delete the installed IODD data.		
						8	Initialize including network setting and language as well. I/O assignment is unused. IODD data is not deleted.		

Master Unit parameter numbers DEC (HEX)	Target number 0 to 15: corresponds to channel number, 0: This product	Data Name	R/W	Format	Length in bytes	Value	Front panel controls (Master Unit parameter numbers)	Communication from host master station	Firmware version
2 (2 h)	0	Network type	RW	UINT	1	0 (default value)	● (M2)	●	
						1	● (M2)		
3 (3 h)	0	Network No. (for CC-Link IE Field only)	RW	UINT	1	1 - 239 (Default value: 1)	● (M3)	●	
4 (4 h)	0	Display brightness	RW	UINT	1	1 - 20 (Default value: 7) Display brightness Values multiplied by 5 are equivalent to % display.	● (M4)	●	
5 (5 h)	0	Language	RW	UINT	1	0 (default value)	● (M5)	●	
						1	● (M5)		
						2	● (M5)		
						3	● (M5)		
						4	● (M5)		
						5	● (M5)		
						6	● (M5)		
						7	● (M5)		
						9	● (M5)		
						10	● (M5)		

Master Unit parameter numbers DEC (HEX)	Target number 0 to 15: corresponds to channel number, 0: This product	Data Name	R/W	Format	Length in bytes	Value	Front panel controls (Master Unit parameter numbers)	Communication from host master station	Firmware version														
6 (6 h)	0	Time zone (For CC-Link IE TSN only)	RW	UINT	1	0 - 48 (Default value: 24) Set the time difference from the CC-Link IE TSN network time displayed as the network time (setting value number: M65). The value actually set on the product is this set value minus 24. UTC is the standard for CC-Link IE TSN, so if the time zone is set as 9 (write 33), it will display Japan time (JST). Normally 0 for CC-Link IE Field.	● (M6)	●															
8 (8 h)	0	User tag name of this IO-Link master	RW	STRING	1 - 3 2	Set the product user tag name up to 32 characters.	● (M8)	●															
9 (9 h)	0	I/O assignment batch settings	RW	UINT	1	<table border="1"> <tr> <td>0 (default value)</td> <td>None</td> </tr> <tr> <td>1</td> <td>Change I/O assignment settings for all ports to IO-Link mode.</td> </tr> <tr> <td>2</td> <td>Change I/O assignment for all ports to PNP input mode.</td> </tr> <tr> <td>3</td> <td>Change I/O assignment for all ports to NPN input mode.</td> </tr> <tr> <td>4</td> <td>Change I/O assignment for all ports to PNP output mode.</td> </tr> <tr> <td>5</td> <td>Change I/O assignment for all ports to NPN output mode.</td> </tr> <tr> <td>6</td> <td>Change I/O assignment for all ports to unused.</td> </tr> </table>	0 (default value)	None	1	Change I/O assignment settings for all ports to IO-Link mode.	2	Change I/O assignment for all ports to PNP input mode.	3	Change I/O assignment for all ports to NPN input mode.	4	Change I/O assignment for all ports to PNP output mode.	5	Change I/O assignment for all ports to NPN output mode.	6	Change I/O assignment for all ports to unused.	● (M9)	●	
0 (default value)	None																						
1	Change I/O assignment settings for all ports to IO-Link mode.																						
2	Change I/O assignment for all ports to PNP input mode.																						
3	Change I/O assignment for all ports to NPN input mode.																						
4	Change I/O assignment for all ports to PNP output mode.																						
5	Change I/O assignment for all ports to NPN output mode.																						
6	Change I/O assignment for all ports to unused.																						

Master Unit parameter numbers DEC (HEX)	Target number 0 to 15: corresponds to channel number, 0: This product	Data Name	R/W	Format	Length in bytes	Value	Front panel controls (Master Unit parameter numbers)	Communication from host master station	Firmware version	
10 (A h)	0 - 15	I/O assignment settings	RW	UINT	1	0	IO-Link mode	● (M10)	●	
						1	PNP input mode: Internal pull-down resistance is enabled.			
						2	NPN input mode: Internal pull-up resistance is enabled.			
						3	PNP output mode			
						4	NPN output mode			
						5 (default value)	Not used			
11 (B h)	0 - 15	Input filter time	RW	UINT	1	0 (default value)	None	● (M11)	●	
						1	0.1ms			
						2	1 ms			
						3	5ms			
						4	10ms			
						5	20ms			
12 (C h)	0 - 15	Input hold time	RW	UINT	1	0 (default value)	None	● (M12)	●	
						1	1 ms			
						2	15ms			
						3	100ms			
13 (D h)	0 - 15	IO-Link communication and network error handling	RW	UINT	1	0 (default value)	Clear	● (M13)	●	
						1	Input hold			
						2	Output hold			
						3	All Hold			
						4	Clear (even when stopped)			
						5	Input hold (output cleared when stopped)			

Master Unit parameter numbers DEC (HEX)	Target number 0 to 15: corresponds to channel number, 0: This product	Data Name	R/W	Format	Length in bytes	Value	Front panel controls (Master Unit parameter numbers)	Communication from host master station	Firmware version
16 (10h)	0 - 15	Process input data bit position	RW	INT	1	-1	● (M16)	●	
						0 - 254			
17 (11h)	0 - 15	Transfer source input port	RW	UINT	1	0	● (M17)	●	1.05□□□□□□□□ or later
						1 - 16			

Master Unit parameter numbers DEC (HEX)	Target number 0 to 15: corresponds to channel number, 0: This product	Data Name	R/W	Format	Length in bytes	Value	Front panel controls (Master Unit parameter numbers)	Communication from host master station	Firmware version
18 (12 h)	0 - 15	Pulse input	RW	UINT	1	None	Does not use the counter function.	● (M18)	●
						ABZ	Uses all of phase A, phase B, and phase Z of the incremental encoder. The rotation count is incremented or decremented at the rising edge of the Z phase, with the count value cleared. The count value is incremented at both the rising edge and falling edge of the input pulse.		
						AB	Uses only phase A and phase B of the incremental encoder. The count value is incremented at both the rising edge and falling edge of the input pulse.		
						Single	The count value is incremented at both the rising edge and falling edge of the input pulse.		
						Frequency	Measures the frequency of the single-phase pulse input in units of 1 Hz every second.		
						High response	This is used when a high-speed response is required. It measures the frequency of the AB-phase or single-phase pulse input at the rising edge of each input cycle.		
19 (13 h)	0 - 15	Input inversion	RW	UINT	1	None	Passes the input status of the specified port as-is to the inside.	● (M19)	●
						Reverse	Passes the input status of the specified port to the inside after reversing it.		

Master Unit parameter numbers DEC (HEX)	Target number 0 to 15: corresponds to channel number, 0: This product	Data Name	R/W	Format	Length in bytes	Value	Front panel controls (Master Unit parameter numbers)	Communication from host master station	Firmware version
21 (15 h)	0 - 15 (corresponds to port number)	I/O synchronization	RW	UINT	2	0 (default value)	Asynchronous IO-Link communication uses individual devices' fastest times. The digital I/O status is also continually updated. Note For CC-Link IE TSN, the product's internal timer is not synchronized with CC-Link IE TSN network time.	● (M21)	●
						1	Network synchronization Synchronize IO-Link communication or digital I/O transfer with process data transfer to CC-Link IE Field/TSN.		
						2	Using the product's internal timer, at an 0.4 ms cycle, synchronize IO-Link communication or digital I/O transfer between multiple ports with the same setting (I/O synchronization). Note For CC-Link IE TSN, the product's internal timer is synchronized at an 0.8 ms cycle with CC-Link IE TSN network time.		
						3	As above, synchronization at 0.8 ms cycle		
						4	As above, synchronization at 1.6 ms cycle		
						5	As above, synchronization at 3.2 ms cycle		
						6	As above, synchronization at 6.4 ms cycle		
						7 - 1003	Specify the IO-Link communication cycle time at 0.4 ms to 100.0 ms.		

Master Unit parameter numbers DEC (HEX)	Target number 0 to 15: corresponds to channel number, 0: This product	Data Name	R/W	Format	Length in bytes	Value	Front panel controls (Master Unit parameter numbers)	Communication from host master station	Firmware version	
22 (16 h)	0 - 15	Lowest frequency	RW	UINT	1	27.2 Hz	● (M22)	●		
						Measures the lowest frequency with a cycle of 16 rising edges of the pulse input. This ensures stable measured values with improved frequency measurement resolution, although the measurable lowest frequency is 27.2 Hz.				
						13.6 Hz				Measures the lowest frequency with a cycle of 8 rising edges of the pulse input.
						6.8 Hz				Measures the lowest frequency with a cycle of 4 rising edges of the pulse input.
						3.4 Hz				Measures the lowest frequency with a cycle of 2 rising edges of the pulse input.
1.7 Hz	Measures the lowest frequency with a cycle of 1 rising edges of the pulse input.									
29 (1D h)	0 - 15 (corresponds to port number)	Device ID	RW	UINT	3	0x0 to 0xFFFFFFFF (Default value: 0x0)	● (M29)	●		
						This is the device ID used for verification with IO-Link devices. Refer to <i>M29. Device ID</i> in <i>6-4-3 Master Unit Parameter List with Product Front Panel Operation</i> on page 6-38 for details.				

Master Unit parameter numbers DEC (HEX)	Target number 0 to 15: corresponds to channel number, 0: This product	Data Name	R/W	Format	Length in bytes	Value	Front panel controls (Master Unit parameter numbers)	Communication from host master station	Firmware version
30 (1E h)	0 - 15	Device verification	RW	UINT	1	0 (default value)	None Note Even for <i>None</i> , if storage data is already saved in the product, when turning on the power (unit and I/O power), the IO-Link device type ID and storage data type ID will be verified. An error (FF23 h) will occur if the type ID does not match. The revision ID is not verified.	● (M30)	●
						1	Type ID (vendor ID and device ID) verification If the registered type ID and connected device type ID are different, an error (FFFE h: type ID verification error) is generated and the process data with the relevant IO-Link device is treated as invalid. As well, if IO-Link communication is not established within 10 seconds of turning on the I/O power, an error (FFFB h: IO-Link device not connected) is generated. At the same time, the revision ID is also verified.		
						2	Type ID and serial number verification Even if the type IDs (vendor ID and device ID) match, if the serial number is different, an error (FFFC h: serial number verify error) is generated, and the process data with the relevant IO-Link device is invalidated. Other operations are the same as set value 1.		
						3	Type ID + device type name verification Even if the type IDs (vendor ID and device ID) match, if the device type name is different, an error (FFF4 h: type name verification error) is generated, and the process data with the relevant IO-Link device is invalidated. Other operations are the same as set value 1.		

Master Unit parameter numbers DEC (HEX)	Target number 0 to 15: corresponds to channel number, 0: This product	Data Name	R/W	Format	Length in bytes	Value	Front panel controls (Master Unit parameter numbers)	Communication from host master station	Firmware version
31 (1F h)	0 - 15	Automatic device parameter backup	RW	UINT	1	<p>0 (default value) None</p> <p>1 Auto backup When IO-Link device set values are changed, they are automatically backed up in this product. If IO-Link device setting values are changed from this product, the backup operation will automatically start 10 seconds after the last change. Note When a device with a different vendor ID or device ID is connected, backup is executed at every startup, so reset <i>Device verification</i> (set value number: M30) to correct the verification error (FFFE h) as soon as possible.</p> <p>2 Auto restoration At startup, if the IO-Link device set value is different from the one stored in the product, it will be automatically restored (set value downloaded from the product to the IO-Link device). In this case, note that even if the IO-Link device set value is changed, it will be overwritten at the next startup with the data saved in this product.</p> <p>3 Perform auto backup and auto restoration as above together The storage data stored on this product will always match the IO-Link device setting values. In other words, IO-Link device setting values are backed up to this product whenever they are changed. If any setting values are different from the IO-Link device during startup, the setting values stored in this product will be restored.</p> <p>4 Update</p>	● (M31)	●	

Master Unit parameter numbers DEC (HEX)	Target number 0 to 15: corresponds to channel number, 0: This product	Data Name	R/W	Format	Length in bytes	Value	Front panel controls (Master Unit parameter numbers)	Communication from host master station	Firmware version
32 (20 h)	0 - 15	Device parameter backup/restore	RW	UINT	1	0 (default value)	None	● (M32)	●
						1	Execute backup (uploading set values from devices to this product) manually		
						2	Execute restoration (downloading set values from the product to devices) manually		
						3	Delete backup data saved in the product manually		
33 (21 h)	0 - 15	Conditions for applying IODD data	RW	UINT	1	0	Device	● (M33)	●
						1 (default value)	IODD		
40 (28 h)	0 - 15	Process data words auto allocation	RW	UINT	1	0 - 16 (Default value: 2)	Process input data words allocated to RWr	● (M40)	●

Master Unit parameter numbers DEC (HEX)	Target number 0 to 15: corresponds to channel number, 0: This product	Data Name	R/W	Format	Length in bytes	Value	Front panel controls (Master Unit parameter numbers)	Communication from host master station	Firmware version
41 (29 h)	0 - 15	Process output data words allocation	RW	UINT	1	0 - 16 (Default value: 2) Process output data words allocated to RWw	● (M41)	●	
42 (2A h)	0	Process data words auto allocation	RW	UINT	1	0 (default value) None 1 Auto allocation	● (M42)	●	
43 (2B h)	0 - 15	Process data sequence conversion	RW	UINT	1	0 (default value) Little endian LSB Accesses the process data of the IO-Link device by converting it into little-endian format starting from the lower byte (LSB). 1 Big endian MSB Accesses the process data of the IO-Link device as-is in big-endian format. 2 Little endian MSB Accesses the process data of the IO-Link device by converting it into little-endian format starting from the upper byte (MSB). 3 Swap bytes Accesses the process data of the IO-Link device by swapping the upper and lower bytes in units of one word (two bytes).	● (M43)	●	1.05□□□□□□ or later

Master Unit parameter numbers DEC (HEX)	Target number 0 to 15: corresponds to channel number, 0: This product	Data Name	R/W	Format	Length in bytes	Value			Front panel controls (Master Unit parameter numbers)	Communication from host master station	Firmware version
44 (2C h)	0	Time stamp	RW	UINT	1	0 (default value)	No	Refer to M44. Time stamp in 6-4-3 Master Unit Parameter List with Product Front Panel Op- eration on page 6-38 for de- tails.	● (M44)	●	
						1	Serial				
						2	Common Era BCD				
						3	Serial + parity				
						4	Common Era BCD+ parity				
51 (33 h)	0 - 15	IO-Link cycle time	R	UINT	2	1 - 1000	0.1 ms increments	● (M51)	●		
52 (34 h)	0 - 15	IO-Link transmission rate	R	UINT	1	0	Not communicating	● (M52)	●		
						1	COM1				
						2	COM2				
						3	COM3				
53 (35 h)	0 - 15	Number of IO-Link communication errors	R	UINT	1	0 - 255	To clear, write 1 in set value 114 h offset +0.	● (M53)	●		

Master Unit parameter numbers DEC (HEX)	Target number 0 to 15: corresponds to channel number, 0: This product	Data Name	R/W	Format	Length in bytes	Value		Front panel controls (Master Unit parameter numbers)	Communication from host master station	Firmware version
54 (36 h)	0 - 15	IO-Link ISDU checksum errors	R	UINT	1	0 - 255	To clear, write 1 in set value 114 h offset +0.	● (M54)	●	
55 (37 h)	0 - 15	IO-Link transmission rate error	R	INT	2	-1000 - 1000	IO-Link transmission rate error (0.1% unit, signed)	● (M55)	●	
56 (38 h)	0 - 15	IO-Link signal width error	R	INT	2	-1000 - 1000	IO-Link transmission signal width error (0.1% unit, signed)	● (M56)	●	
57 (39 h)	0 - 15	IO-Link communication mode	R	UINT	1	0 - 7	0: NOCOM 1: STARTUP 2: PREOPERATE 3: OPERATE 5: STARTUP (Rev.1.0) 6: PREOPERATE (Rev.1.0) 7: OPERATE (Rev.1.0)	Refer to M57. Communication mode in 6-4-3 Master Unit Parameter List with Product Front Panel Operation on page 6-38 for details.	● (M57)	●

Master Unit parameter numbers DEC (HEX)	Target number 0 to 15: corresponds to channel number, 0: This product	Data Name	R/W	Format	Length in bytes	Value	Front panel controls (Master Unit parameter numbers)	Communication from host master station	Firmware version
58 (3A h)	0 - 15	Storage backup time	R	STRING	1 7	00:00:00_00/01/ 01 ~ 23:59:59_99/12/ 31 The storage data backup time is displayed as below. Time and date (ex.: 18:59:00 22/12/31) 18:59:00_22/12/31	● (M58)	●	
60 (3C h)	0	System program version of IO-Link master	R	UINT	4	P.PPNNLLFF Display the data version of the program, etc. P.PP: Firmware, NN: Network chip, LL: Logic, FF: Font 4 bytes in decimal.	● (M60)	●	
61 (3D h)	0	Operating time	R	UINT	4	0 to 2097151 (239 years) Product cumulative operating time information (unit: hours)	● (M61)	●	
62 (3E h)	0	Display drive time	R	UINT	4	0 to 262143 (30 years) Product display operating time information (unit: hours)	● (M62)	●	
63 (3F h)	0 (corresponds to this product)	I/O power supply voltage	R	UINT	2	0 - 308 Voltage supplied to product I/O power supply (unit: 0.1 V)	● (M63)	●	

Master Unit parameter numbers DEC (HEX)	Target number 0 to 15: corresponds to channel number, 0: This product	Data Name	R/W	Format	Length in bytes	Value	Front panel controls (Master Unit parameter numbers)	Communication from host master station	Firmware version
64 (40 h)	0 (corresponds to this product)	Internal temperature	R	INT	2	-2739 - 10457 Product internal temperature (unit: 0.1°C)	● (M64)	●	
65 (41 h)	0 (corresponds to this product)	Network time	R	STRING	2 2	00:00:00.0000_00/01/01 ~ 23:59:59.0000_99/12/31 Time and date (ex.: 18:59:00.0000 22/12/31) 18:59:00.0000_22/12/31	● (M65)	●	
66 (42 h)	0 (corresponds to this product)	Network communication cycle	R	UINT	2	0 - 1500 Returns the upper network communication cycle in 0.01 ms units. It will be forced to operate at a 15 ms cycle if the host network is disconnected.	● (M66)	●	

6-4-2 Data for Access from PLC

Master Unit parameter numbers	Target numbers	Data Name	R/W	Offset	Value	Front panel controls	Communication from host master station
100 h	0 - 15 (corresponds to port number)	Latest error code readout by port	R	+0	Error code lower	5-1-5 Event/Error Display Window on page 5-8	●
				+1	Error code upper		
				+2	Lower designated index number causing error		
				+3	Upper designated index number causing error		
				+4	Designated index number causing error		
+5 - 26	Error time and date text string (in order of generation) See the form below. HH:MM:SS YY:MN:DD HH: hour, MM: minute, SS: second, YY: year last two digits, MN: month, DD: day Ex.: Generated at 18:59:00 on February 19, 2020: 18:59:00 20/02/19 Note When 100- μ s unit data is added, HH:MM:SS:ssss YY:MN:DD (ssss: seconds in 100- μ s units)						

Master Unit parameter numbers	Target numbers	Data Name	R/W	Offset	Value	Front panel controls	Communication from host master station
101 h	0 - 15 (corresponds to port number)	Event data read-out by port	R	+0	Event flag	5-1-5 Event/Error Display Window on page 5-8	●
				+1	Event #1 type *1		
				+2	Event Code Lower		
				+3	Event Code Upper		
				+4	00 h (fixed)		
				+5	Event #2 type *1		
				+6	Event Code Lower		
				+7	Event Code Upper		
				+8	00 h (fixed)		
				+9	Event #3 type *1		
				+10	Event Code Lower		
				+11	Event Code Upper		
				+12	00 h (fixed)		
				+13	Event #4 type *1		
				+14	Event Code Lower		
				+15	Event Code Upper		
				+16	00 h (fixed)		
				+17	Event #5 type *1		
				+18	Event Code Lower		
				+19	Event Code Upper		
				+20	00 h (fixed)		
				+21	Event #6 type *1		
				+22	Event Code Lower		
				+23	Event Code Upper		
				+24	00 h (fixed)		
				+25 - 150	The text string for generation times of events #1 to #6 will be displayed (in order) after the event #. Ex. 1: Event #1 only generated at 19:15:32 on June 24, 2020: (1) 19:15:32 20/06/24 Ex. 2: Events #1 to #6 all generated at different times: (1) 19:15:32 20/06/24 (2) 19:10:18 20/06/24 (3) 18:25:32 20/06/24 (4) 19:05:48 20/06/24 (5) 19:15:32 20/06/24 (6) 19:10:18 20/06/02		

Master Unit parameter numbers	Target numbers	Data Name	R/W	Offset	Value	Front panel controls	Communication from host master station	
102 h	0	Set value readout time from IO-Link devices (binary data)	R	+0	15.265 μ s unit data lower	-	●	
				+1	15.265 μ s unit data upper			
				+2	Set 0 as January 1, 1970, 00:00:00, counting data every second, least-significant			
				+3	As above 2nd byte			
				+4	As above 3rd byte			
				+5	As above, most-significant			
				+6	Lower parity information with readout set values as word units with exclusive disjunction (XOR) at 35 AC h			
				+7	As above, upper			
	1	Set value readout time from IO-Link devices (CE BCD data)	R	+0	15.265 μ s unit data lower			
				+1	15.265 μ s unit data upper			
				+2	s			
				+3	min			
				+4	hr			
				+5	day			
				+6	month			
				+7	year			
				+8	Lower parity information with readout set values as word units with exclusive disjunction (XOR) at 0x35AC			
				+9	As above, upper			
	2	Set value readout time from IO-Link devices (text string data)	R	-	A 27-character text string will be displayed. Ex.: 2020/2/29 18:59:0.1234 parity 8B61 h → 18:59:00.1234 20/02/29 8B61			
	103 h	0 (corresponds to this product)	Event/error message readout	R	-	Executing readout switches the display to the event/error display window.	5-1-5 Event/Error Display Window on page 5-8	●
					+0	Applicable port (0 to 15)		
+1					Designated index number causing error/event qualifier			
+2					Lower index number in error			
+3					Upper index number in error			
+4					Error code lower			
+5					Error code upper			
+6					Message text string			
+7	(continues)							

Master Unit parameter numbers	Target numbers	Data Name	R/W	Offset	Value	Front panel controls	Communication from host master station
104 h	0 (corresponds to this product)	Button operation	R	+0	Returns the status of the currently pressed button. Value is the same as below.	-	●
			W	-	Writes the decimal below. 1: Right button operation 2: Left button operation 4: ↑ button operation 8: ↓ button operation 16: CANCEL button operation 32: ENTER button operation		
105 h	0	Event/error clear	R	-	Executes operation equivalent to pressing the ENTER, Down, and Up buttons on the event/error menu. Executes with readout.	5-1-5 <i>Event/Error Display Window</i> on page 5-8	●
	1	Go to next event					
	2	Return to previous event					
106 h	0 (corresponds to this product)	Operation lock	RW	-	Bit 0: Master Unit parameter write lock	-	●
					Bit 1: Device set value write lock		
					Bit 2: /Event/error clear operation lock		
					Bit 3: All button operation lock		
					Note Start up while pressing the CANCEL button to release the lock temporarily.		
107 h	0	Readout display text string (2nd row)		+0 - +499	Text string on display Character codes: Japanese: Shift-JIS Simplified Chinese: GB2312 Traditional Chinese: Big-5 Korean: EUC-kr	-	●

Master Unit parameter numbers	Target numbers	Data Name	R/W	Offset	Value	Front panel controls	Communication from host master station
108 h	1	Right button operation response	R	-	<p>Operation response when remotely operating product buttons is stored under the following decimals. Responses are as below.</p> <p>1: Referencing set values</p> <p>10-19: Digit position of set values being edited (equivalent to digits 1-10)</p> <p>100 up: Digit position in text string being edited</p> <p>Values up to 255 are 1-byte responses; values from 256 up are 2-byte responses.</p> <p>Even if buttons are remotely operated here, the display off timer will not be cleared.</p>	-	●
	2	Left button operation response					
	4	Up button operation response					
	8	Down button operation response					
	16	CANCEL button operation response					
	32	ENTER button operation response					
	192	Process data information update operation response					
109 h	0 (corresponds to this product)	Readout of port numbers displayed	R	+0	When the IO-Link device numbers specified in writing are out of range, an out-of-range error will be generated without switching. The readout will return the current port numbers.	-	●
10A h	0 (corresponds to this product)	Find Me requests	RW	+0	0: Cancel a Find Me request to the product. 1: Send a Find Me request to the product. During Find Me, the event/error display will blink and the display will show <i>I am here</i> . Press any button to clear Find Me.	-	●
10B h *2	0 - 15	IO-Link device process input data read	R	+0 - +31	Reads IO-Link device process input data on each port. Data byte count is the actual process input data byte count. Data format is big-endian.	-	●
		IO-Link device process output data control switching	W	+0	Switches the IO-Link output data on each port between updating from the field network side and separating to enable write data from this 0x10C.	-	●
				0x55 (85)	In process output data, write values from 0x10C have priority. When the product is powered OFF, updates from the field network are once again enabled.	-	●
				0xBA (186)	In process output data, updates from the field network are enabled.	-	●
10C h *2	0 - 15	IO-Link device process output data read	R	+0 - +31	Reads IO-Link device process output data on each port. Data byte count is the actual process input data byte count. Data format is big-endian.	-	●
		IO-Link device process output data write	W	+0 - +31	Writes IO-Link device process output data on each port. Data format is big-endian. Write values here become enabled when 0x55 is written to 0x10B.	-	●

Master Unit parameter numbers	Target numbers	Data Name	R/W	Offset	Value	Front panel controls	Communication from host master station
10D h	0 - 15 (corresponds to port number)	Type name thumb value registration for verification	R	+0 - +1	Write the type name as a text string to calculate and store the thumb value. The readout value will be a 16-bit thumb value.	-	●
			W	+0 - +63			
10E h	0 - 15 (corresponds to port number)	Vendor ID and device ID registered for verification	RW	+0 - +1	Registered IO-Link device vendor ID	-	●
				+2 - +4	Registered IO-Link device ID		
				+5	0		
				+6	Registered IO-Link device revision ID Value 10 h indicates that the revision ID is 1.0. Value 11 h indicates that the revision ID is 1.1.		
10F h	0 - 15 (corresponds to port number)	Write serial number to be registered	W	+0 - +15	Writes the serial number used for verification with IO-Link devices.	-	●
110 h	0 - 15 (corresponds to port number)	Readout of vendor ID/device ID of storage data backed up in this product and registered vendor ID/device ID and serial number	R	+0 - +1	Vendor ID in product backup data Note In the case of a vendor ID mismatch, it will be invalid and 0 will be read out.	-	●
				+2 - +4	Device ID in product backup data Note In the case of a device ID mismatch, it will be invalid and 0 will be read out.		
				+5	0		
				+6 - +7	Storage backup execution times since power on		
				+8 - +9	Storage restoration execution times since power on		
				+10 - +26	Text string of date and time of backup		
111 h	0 (corresponds to this product)	Diagnostic information	R	+0	Main memory (EEPROM) checksum error count	-	●
				+1	Sub memory (Flash) checksum error count		
				+2	1: CC-Link IE Field synchronization signal enabled (CC-Link IE TSN always 0)		
				+3	Bit 0-5: Result of pressing switch alone in past		
				+4 - 5	Display device drive power supply voltage (0.1 V unit)		
				+6	Transient communication timeout count		
				+7	Main memory (EEPROM) write frequency. Updated every 450 seconds, with an alarm generated at over 200.		
				+8	Maximum value of the internal temperature measured inside the product. (unit: °C)		
				+9	Set value version number (0)		
				+10	Network communication error count		
				+11	Storage function state number (normally 0, changes when storage-related functions operate)		
				+12 - +13	Interlock status (bits 0-15 correspond to ports 0-F h)		

Master Unit parameter numbers	Target numbers	Data Name	R/W	Offset	Value	Front panel controls	Communication from host master station
112 h	0 (corresponds to this product)	Output overcurrent status	R	+0 - +1	Current output overcurrent status. Bits 0-15 are equivalent to I/O ports 0-9 and A-F.	-	●
				+2 - +17	Output overcurrent count for ports 0-F. Counted up to 255.		
			W	+0	Write 1 to clear all ports' output overcurrent count. Write 2-17 to clear ports 0-F separately.		
113 h	0 - 15 (corresponds to port number)	Read vendor ID and device ID of IO-Link device currently connected.	R	+0 - +1	Vendor ID	-	●
				+2 - +4	Device ID		
				+5	Always 0.		
				+6	Revision ID		
				+7	Always 0.		
+8 - +9	Function ID						
114 h *3	0 - 15 (corresponds to port number)	IO-Link device diagnostic information	R	+0	Number of IO-Link communication errors.	-	●
			R	+1	IO-Link ISDU sum error count		
			R	+2 - +3	IO-Link transmission rate error (0.1% unit, signed)		
			R	+4 - +5	IO-Link transmission signal width error (0.1% unit, signed)		
			R	+6 - +7	IO-Link cycle time (0.1 ms unit)		
			R	+8	IO-Link transmission rate (0: not communicating, 1: COM1, 2: COM2, 3: COM3)		
			R	+9	Process input data byte count		
			R	+10	Process output data byte count		
			R	+11	IO-Link communication status (0: NOCOM, 1: STARTUP, 2: PREOPERATE, 3: OPERATE, 4-7: Same as 0-3 with IO-Link Revision 1.0)		
			R	+12	IO-Link device on-request data byte count		
			R	+13	Process input data disabled (1: Disabled)		
			R	+14	Reserved		
			0	Clear IO-Link communication error count	W		
+0	Write 1 to clear all ports' ISDU checksum error count. Write 2-17 to clear ports 0-F separately.						
1	Clear IO-Link ISDU checksum error count						
120 h	0	IO-Link device index number specification when accessing IO-Link devices	W	+0	Index number lower	-	●
				+1	Index number upper		
				+2	Subindex number		
				+3	IO-Link device port number to be accessed (0-15)		

Master Unit parameter numbers	Target numbers	Data Name	R/W	Offset	Value	Front panel controls	Communication from host master station		
121 h	0	Readout data/ write data when accessing speci- fied index number	RW	-	Readout data/write data Data under 4 bytes will be converted to little-en- dian.	-	●		
	1			-	Readout data/write data Even data under 4 bytes will not be converted to little-endian.				
123 h *4	10, 11, 12, 13, 16, 17, 30, 31, 33, 40, 41, 43	16-port batch read/write	RW	+0 - +15	Batch reads or writes 16 ports' setting values to the Master Unit setting value specified by the tar- get number. The setting value data has a total of 16 bytes, one per port, from port 0 to port 1 and finally port F.	-	●		
124 h *5	0	Read all ports' event and error in- formation	R	+0 - +1	Event generation status for ports 0 to F. Event occurring on port 0 at bit 0:1 ... Event occurring on port F at bit 15:1	-	●		
				+2 - +5	Reserved			-	●
				+6 - +7	Port 0 event code			-	●
				+8 - +9	Port 1 event code			-	●

Master Unit parameter numbers	Target numbers	Data Name	R/W	Offset	Value	Front panel controls	Communication from host master station
				⋮		-	●
				+36 - +37	Port F event code	-	●
				+38 - +39	Error generation status for ports 0 to F. Error occurring on port 0 at bit 0:1 ... Error occurring on port F at bit 15:1	-	●
				+40 - +41	Bit 0 is 1: Master Unit error occurring	-	●
				+42 - +43	Master Unit error codes	-	●
				+44 - +45	Port 0 error code	-	●
				+46 - +47	Port 1 error code	-	●
				⋮		-	●
				+74 - +75	Port F error code	-	●
	1	Read all ports' event information	R	+0 - +1	Event generation status for ports 0 to F. Event occurring on port 0 at bit 0:1 ... Event occurring on port F at bit 15:1	-	●
				+2 - +5	Reserved	-	●
				+6 - +7	Port 0 event code	-	●
				+8 - +9	Port 1 event code	-	●
				⋮		-	●
				+36 - +37	Port F event code	-	●
	2	Read all ports' error information	R	+0 - +1	Error generation status for ports 0 to F. Error occurring on port 0 at bit 0:1 ... Error occurring on port F at bit 15:1	-	●
				+2 - +3	Bit 0 is 1: Master Unit error occurring	-	●
				+4 - +5	Master Unit error codes	-	●
				+6 - +7	Port 0 error code	-	●
				+8 - +9	Port 1 error code	-	●
				⋮		-	●
				+36 - +37	Port F event code	-	●

Master Unit parameter numbers	Target numbers	Data Name	R/W	Offset	Value	Front panel controls	Communication from host master station
1FE h	0 - 31	Readout of IO-Link communication trace data	R	+0 - +127	From the position where the port number was specified, 128 bytes of trace send/receive data will return as a hexadecimal text string. When it is read out, the trace ends. The specified port number 31 is the most recent trace data, 30 is the previous one, and 0 is the oldest data. A ">" is inserted at the start of the send data and a ":" at the start of the receive data.	-	●
	0	Start of IO-Link communication trace	W	+0	Bits 3-0: IO-Link device port number Saves the specified IO-Link device send/receive data to buffer memory (4096 bytes). Bit 5: Set to 1 to stop the trace when an IO-Link communication error is generated. Bit 6: Set to 1 to stop the trace when an ISDU communication negative response is generated. Bit 7: Set to 1 to stop the trace when the buffer is full.	-	●
				+1	Bit 0: Set to 1 to add a line break instead of ">" at the start of send data.		
1FF h	0 (corresponds to this product)	Readout of MAC address and serial No.	R	+0 - +5	6-byte MAC address data		
				+6	I/O voltage measurement calibrated value		
				+7	Internal temperature measurement calibrated value		
				+8 - 23	Product serial number (16 characters)		

*1. Event type details (from IO-Link specifications)

Bits 7-6 Event generation type 0: Reservation, 1: Single, 2: Generated, 3: Cleared

Bits 5-4 Event type 0: Reservation, 1: Notification, 2: Warning, 3: Error

Bit 3 Event generation source 0: Device, 1: Master

Bits 2-0 Event cause 0: Unclear, 1-3: Reservation, 4: Application, 5-7: Reservation

*2. Master Unit parameter numbers 10B and 10C are compatible with firmware version 1.00□□□□□□ or later.

*3. Master Unit parameter number 114 is compatible with firmware version 1.04□□□□□□ or later.

*4. Master Unit parameter number 123 is compatible with firmware version 1.05□□□□□□ or later.

*5. Master Unit parameter number 124 is compatible with firmware version 1.06□□□□□□ or later.

6-4-3 Master Unit Parameter List with Product Front Panel Operation

Setting Items (setting value number followed by setting name)	R/W	Setting for product or port	Setting value range	Description
M1. IO-Link Master Unit parameters reset	RW	This product	No (default value)	Do not reset Master Unit parameters to factory default.
			IO-Link	Reset Master Unit parameters to factory default. The I/O assignment settings will be changed to IO-Link mode for all ports. The registered vendor ID, device ID, serial number and storage data will also be deleted. The network type, network number and language will not be reset to the factory defaults.
			pnp Input	Similarly, reset Master Unit parameters to factory defaults with the I/O assignment settings set to PNP input mode for all ports.
			nnp Input	Similarly, reset Master Unit parameters to factory defaults with the I/O assignment settings set to NPN input mode for all ports.
			PNP Output	Similarly, reset Master Unit parameters to factory defaults with the I/O assignment settings set to PNP output mode for all ports.
			NPN Output	Similarly, reset Master Unit parameters to factory defaults with the I/O assignment settings set to NPN output mode for all ports.
			Unused	Similarly, reset Master Unit parameters to factory defaults with the I/O assignment settings set to unused.
			Delete IODD	Delete the installed IODD data. Setting values will not be reset to the factory defaults.
M2. Network type	RW	This product	CC-Link IE Field (default value)	Use CC-Link IE Field as the host network standard. ×10 (upper) and 0 - 9 (lower) are valid settings for the station number.
			CC-Link IE TSN	Use CC-Link IE TSN as the host network standard. ×16 (upper) and 0 - 15 (lower) are valid settings for the station number.
M3. Network No (for CC-Link IE Field only)	RW	This product	1 - 239 (Default value: 1)	Specify the network number for CC-Link IE Field (this will not be displayed in the setting menu for CC-Link IE TSN).
M4. Display brightness	RW	This product	5 - 100% (default value: 35%)	Set the brightness of the display.
M5. Language	RW	This product	English (default value)	Set the display language to English.
			Japanese	Set the display language to Japanese. Shift-JIS is used for the character code.
			German	Set the display language to German.
			Chinese (Simplified)	Set the display language to Chinese (simplified). GB2312 is used for the character code.
			French	Set the display language to French.
			Spanish	Set the display language to Spanish.
			Portuguese	Set the display language to Portuguese.
			Italian	Set the display language to Italian.
			Korean	Set the display language to Korean. EUC-kr is used for the character code.
Chinese (Traditional)	Set the display language to traditional Chinese. Big-5 is used for the character code.			

Setting Items (setting value number followed by setting name)	R/W	Setting for product or port	Setting value range	Description
M6. Time zone -UTC- (for CC-Link IE TSN only)	RW	This product	-24 - 24 (default value: 0)	Set the time difference from the CC-Link IE TSN network time displayed as the network time (setting value number: M65). UTC is the standard used for CC-Link IE TSN, so setting a value of "9" for the time difference will display Japanese time (JST). Normally 0 for CC-Link IE Field.
M8. User tag name of this IO-Link master	RW	This product	Up to 32 characters	Set the user tag name for this product.
M9. I/O assignment batch setting	RW	All ports	No (default value)	Do not change the I/O assignment settings for all ports at once.
			IO-Link	Change I/O assignment settings for all ports to IO-Link mode.
			pnP Input	Change I/O assignment for all ports to PNP input mode.
			npN Input	Change I/O assignment for all ports to NPN input mode.
			PNP Output	Change I/O assignment for all ports to PNP output mode.
			NPN Output	Change I/O assignment for all ports to NPN output mode.
M10. I/O assignment settings	RW	Each port	IO-Link	Connect the IO-Link device to the applicable I/O and perform control using process data.
			pnP Input	Connect a PNP output sensor device to the applicable I/O.
			npN Input	Connect a NPN output sensor device to the applicable I/O.
			PNP Output	Connect a PNP input actuator device to the applicable I/O.
			NPN Output	Connect a NPN input actuator device to the applicable I/O.
			Unused (default value)	Turn input OFF and output nothing for the applicable I/O.
M11. Input filter time	RW	Each port	No (default value)	Do not set a noise removal filter.
			0.1ms	Set a 0.1 ms noise removal filter on PNP/NPN input. Detect pulse widths exceeding 0.1 ms.
			1 ms	Set a 1 ms noise removal filter on PNP/NPN input. Detect pulse widths exceeding 1 ms.
			5ms	Set a 5 ms noise removal filter on PNP/NPN input. Detect pulse widths exceeding 5 ms.
			10ms	Set a 10 ms noise removal filter on PNP/NPN input. Detect pulse widths exceeding 10 ms.
			20ms	Set a 20 ms noise removal filter on PNP/NPN input. Detect pulse widths exceeding 20 ms.
M12. Input hold time	RW	Each port	No (default value)	Do not set the input hold function.
			1 ms	Hold for 1 ms when PNP/NPN input turns ON.
			15ms	Hold for 15 ms when PNP/NPN input turns ON.
			100ms	Hold for 100 ms when PNP/NPN input turns ON.
M13. IO-Link communication and network error handling	RW	Each port	Clear (default value)	Clear process input data to "0" when communication with the IO-Link device is disconnected. Clear process output data to "0" and turn PNP/NPN output OFF when CC-Link IE Field/TSN is disconnected.
			Input Hold	Hold process input data when communication with the IO-Link device is disconnected. Turn output OFF.
			Output Hold	Hold process output data and PNP/NPN output when CC-Link IE Field/TSN is disconnected. Turn input OFF.
			All Hold	Hold process input data when communication with the IO-Link device is disconnected. Hold process output data and PNP/NPN output when CC-Link IE Field/TSN is disconnected.

Setting Items (setting value number followed by setting name)	R/W	Setting for product or port	Setting value range	Description
M16. Bit assignment of Process input data	RW	Each port	Valid judgment	Turns ON the digital input bit for the corresponding port when the IO-Link device's process input data is valid.
			0 (default value) to 254	Specifies which bit from the first bit of the process input data defined as boolean (bit) data to use as the input ON/OFF information. Specification is not possible with data formats other than boolean, such as integer.
M17. Input port to output	RW	Each port	None (default value)	Turns ON or OFF the PNP/NPN output based on the process output data bit information.
			0 - 15	Turns ON or OFF the PNP/NPN output based on the input bit information for "the specified port number + 1". Use for external output as is of IO-Link device process input data.
M18. Pulse input	RW	Each port	None	Does not use the counter function.
			ABZ	Uses all of phase A, phase B, and phase Z of the incremental encoder. The rotation count is incremented or decremented at the rising edge of the Z phase, with the count value cleared. The count value is incremented at both the rising edge and falling edge of the input pulse.
			AB	Uses only phase A and phase B of the incremental encoder. The count value is incremented at both the rising edge and falling edge of the input pulse.
			Single	The count value is incremented at both the rising edge and falling edge of the input pulse.
			Frequency	Measures the frequency of the single-phase pulse input in units of 1 Hz every second.
			High response	This is used when a high-speed response is required. It measures the frequency of the AB-phase or single-phase pulse input at the rising edge of each input cycle.
M19. Input inversion	RW	Each port	None	Passes the input status of the specified port as-is to the inside.
			Reverse	Passes the input status of the specified port to the inside after reversing it.

Setting Items (setting value number followed by setting name)	R/W	Setting for product or port	Setting value range	Description
M21. I/O synchronization	RW	Each port	Asynchronous (default value)	IO-Link communication uses individual devices' fastest times. The digital I/O status is updated as needed. If anything other than <i>Asynchronous</i> is set for the setting value, the actual cycle time for IO-Link will be the same or longer compared with asynchronous. The IO-Link cycle time value written to the IO-Link device will be the asynchronous value. Note For CC-Link IE TSN, the internal timer of this product will not be synchronized with the network time.
			Network synchronous	Synchronize IO-Link communication or digital I/O transfer for the specified port with the transfer of process data to CC-Link IE Field/TSN.
			0.4 ms Synchronous timer	Use the internal timer of this product to synchronize (I/O synchronization) IO-Link communication or digital I/O transfer among multiple ports with the same settings, at a cycle of 0.4, 0.8, 1.6, 3.2 or 6.4 ms. The synchronous timer calculates data under 4 seconds for the network time counted every 15.26 μ s as $\times 625 \div 256$ and converts it to a time in 6.25 μ s increments, with the lower 10 bits (0 - 1023) as the timer value from 0 - 6.4 ms. Note For CC-Link IE TSN, the internal timer of this product will be synchronized with the CC-Link IE TSN network time at a cycle of 0.4, 0.8, 1.6, 3.2 or 6.4 ms. The <i>Synchronization establishment flag</i> turns ON when the internal timer of this product is synchronized with the network time (within $\pm 20 \mu$ s).
			0.8 ms Synchronous timer	
			1.6 ms Synchronous timer	
			3.2 ms Synchronous timer	
			6.4 ms Synchronous timer	
			0.4 - 100.0 ms	
M22. Lowest frequency	RW	Each port	27.2 Hz	Measures the lowest frequency with a cycle of 16 rising edges of the pulse input. This ensures stable measured values with improved frequency measurement resolution, although the measurable lowest frequency is 27.2 Hz.
			13.6 Hz	Measures the lowest frequency with a cycle of 8 rising edges of the pulse input.
			6.8 Hz	Measures the lowest frequency with a cycle of 4 rising edges of the pulse input.
			3.4 Hz	Measures the lowest frequency with a cycle of 2 rising edges of the pulse input.
			1.7 Hz	Measures the lowest frequency with a cycle of 1 rising edges of the pulse input.
M29. Device ID	RW	Each port	0 - FFFFFFF h	This is the device ID of the IO-Link device used with M30. <i>Device verification.</i> There is normally no need to set this. However, it may be possible to switch functionality for some IO-Link devices by changing the registered device ID here. To do so, specify the registration device ID here in hexadecimal. If the setting value is changed, the IO-Link device will begin communicating again from the start.

Setting Items (setting value number followed by setting name)	R/W	Setting for product or port	Setting value range	Description
M30. Device verification	RW	Each port	No (default value)	<p>Communicate unconditionally with the connected IO-Link device. The registered type ID (vendor ID and device ID) will also be deleted.</p> <p>Note 1. If there is already storage data in this product, the type ID of the connected IO-Link device will be compared with the type ID of the storage data when the power (module power supply and I/O power supply) is turned ON, even if this is set to <i>None</i>. An error (FF23 h) will be generated if they differ.</p> <p>Note 2. An error (FFFB h) will not occur even if IO-Link communication is established 10 seconds after I/O power supply is turned ON.</p>
			Type ID	<p>Transfer process data only if the device is the same as the registered type ID (vendor ID and device ID). If the type ID differs, an error (FFFE h) will occur and process data with the applicable IO-Link device will be invalidated.</p> <p>When the setting value is written, the type (vendor ID and device ID), type name sum value and serial number of the connected IO-Link device will be registered.</p> <p>Note 1. An error (FFFB h) will occur if IO-Link communication is not established within 10 seconds after I/O power supply is turned ON.</p> <p>Note 2. The revision ID will also be verified.</p>
			Serial No.	<p>Transfer process data only for devices where the serial number is the same as the registered type (vendor ID and device ID). If the type ID differs, an error (FFFE h) will occur and process data with the applicable IO-Link device will be invalidated.</p> <p>If the serial number differs, an error (FFFC h) will occur and process data will be invalidated. Automatic restore will be performed.</p> <p>When the setting value is written, the type (vendor ID and device ID), type name sum value and serial number of the connected IO-Link device will be registered.</p> <p>Note 1. An error (FFFB h) will occur if IO-Link communication is not established within 10 seconds after I/O power supply is turned ON.</p> <p>Note 2. The revision ID will also be verified.</p>
			Type name	<p>Transfer process data only if the device is the same as the registered type (vendor ID and device ID) and type name. If the type ID differs, an error (FFFE h) will occur and process data with the applicable IO-Link device will be invalidated.</p> <p>If the type name differs, an error (FFF4 h) will occur and process data will be invalidated. Automatic restore will be performed.</p> <p>When the setting value is written, the type (vendor ID and device ID), type name sum value and serial number of the connected IO-Link device will be registered.</p> <p>Note 1. An error (FFFB h) will occur if IO-Link communication is not established within 10 seconds after I/O power supply is turned ON.</p> <p>Note 2. The revision ID will also be verified.</p>

Setting Items (setting value number followed by setting name)	R/W	Setting for product or port	Setting value range	Description
M31. Automatic device parameter backup	RW	Each port	No (default value)	Restore and backup are not automatically performed. Storage functionality is controlled manually (M32. Device parameter backup/restore).
			Backup	Automatically perform a backup (upload setting values to this product) when there is a change to an IO-Link device setting value. If IO-Link device setting values are changed from this product, the backup operation will automatically start 10 seconds after the last change. Note If a device with a different vendor ID or device ID is connected, a backup will be performed each time upon startup. Re-configure M30. <i>Device verification</i> immediately to clear the verification error (FFFE h).
			Restore	At startup, if the IO-Link device set value is different from the one stored in the product, it will be automatically restored (set value downloaded from the product to the IO-Link device). In this case, note that even if the IO-Link device set value is changed, it will be overwritten at the next startup with the data saved in this product.
			Both	Automatically perform both backup and restore. The storage data stored on this product will always match the IO-Link device setting values. In other words, IO-Link device setting values are backed up to this product whenever they are changed. If any setting values are different from the IO-Link device during startup, the setting values stored in this product will be restored.
			Update	Saves a backup of the IO-Link device settings as storage data without generating an error even if the device ID of the connected IO-Link device differs from the device ID stored in this product. Note that connecting an incorrect IO-Link device accidentally allows the backup of the IO-Link device's settings to overwrite the existing storage data.
M32. Device parameter backup/restore	RW	Each port	No (default value)	Do not backup/restore setting values manually.
			Backup	Manually backup the IO-Link device (upload setting values from the device to this product).
			Restore	Manually restore to the IO-Link device (download setting values from this product to the device). Note This will not be performed if there is no backup data stored in this product.
			Delete	Delete backup data stored in this product. Note This will not be performed if there is no backup data stored in this product.
M33. Conditions for applying IODD data	RW	Each port	Device	For the GD Series, this function cannot be used because IODD installation is not supported.
			IODD (default value)	

Setting Items (setting value number followed by setting name)	R/W	Setting for product or port	Setting value range	Description
M40. Process input data words allocation	RW	Each port	0 - 16 (default value: 2)	<p>Set the number of words allocated to this product for the process input data of the applicable IO-Link device.</p> <p>If the number of set words is smaller than the number of bytes of the process input data for the connected IO-Link device, process input data exceeding the set size will be ignored (it will not be transferred from the IO-Link device to this product).</p> <p>If the number of set words is larger than the number of bytes of the process input data for the connected IO-Link device, "0" will be transferred in the portion of data exceeding the size of the process input data from the IO-Link device to this product.</p> <p>There is a total of 256 words for all ports. The portion of process input data exceeding 256 words (512 bytes) will be ignored (it will not be transferred from the IO-Link device to this product).</p>
M41. Process output data words allocation	RW	Each port	0 - 16 (default value: 2)	<p>Set the number of words allocated to this product for the process output data of the applicable IO-Link device.</p> <p>If the number of set words is smaller than the size of the process output data for the connected IO-Link device, "0" will be transferred in the portion of the process output data exceeding the set size from this product to the IO-Link device.</p> <p>If the number of set words is larger than the size of the process output data for the connected IO-Link device, the portion of data exceeding the size of the process output data will be ignored (it will not be transferred from this product to the IO-Link device).</p> <p>There is a total of 256 words for all ports. "0" will be transferred in the portion of process output data exceeding 256 words (512 bytes) from this product to the IO-Link device.</p>
M42. Process data words auto allocation	RW	This product	No (default value)	Do not perform process data auto allocation.
			Yes	<p>Process input/output data words allocation (setting value number: M40/M41) will be automatically set according to the specified amount of process input/output data for the connected IO-Link device.</p> <p>Perform this with the required IO-Link device connected and all IO-Link communication established.</p> <p>"0" will be written for the number of process input/output data allocation words on any ports without IO-Link communication established.</p>

Setting Items (setting value number followed by setting name)	R/W	Setting for product or port	Setting value range	Description
M43. Process data sequence conversion	RW	Each port	Little endian LSB (default value)	Convert process data for the applicable IO-Link device into little endian format and transfer it to CC-Link IE Field/TSN. Refer to 4-1 Product Functions on page 4-2 for further information.
			Big endian MSB	Leave process data for the applicable IO-Link device in big endian format and transfer it to CC-Link IE Field/TSN. Refer to 4-1 Product Functions on page 4-2 for further information.
			Little endian MSB	Convert process data for the applicable IO-Link device into little endian format and transfer it to CC-Link IE Field/TSN. Refer to 4-1 Product Functions on page 4-2 for further information.
			Swap bytes	Transfers the process data of the IO-Link device to CC-Link IE Field/TSN in units of one word (two bytes) by swapping the upper and lower bytes. Refer to 4-1 Product Functions on page 4-2 for further information.
M44. Time stamp	RW	This product	No (default value)	Do not attach time information and parity information to process input data.
			Serial	Attach the serial time when the process input data was obtained and store it as three-word data, after process input data is allocated. The serial time is a value where the first one word is the result of dividing one second by 65536 (= 15.2 μ s). The remaining two words are used as data to count each second (with Jan. 1, 1970 00:00:00 as "0").
			Common Era BCD	Attach the time and date taking the time zone -UTC- (setting value number: M6) against the network time when process input data was obtained into consideration, and store it as four-word BCD format data, after process input data is allocated. This is a value where the first one word is the result of dividing one second by 65536 (= 15.2 μ s). The remaining three words are six bytes of data containing in order the seconds, minutes, hours, day and month.
			Serial + parity	Store the parity information from the process input data and time information as one word following the serial time described above. Parity information is a value determined by running exclusive OR (XOR) at the individual word level for 35AC h, process input data and time information. Time information is used to prevent data falsification.
			Common Era BCD+ parity	Store the parity information from the process input data and time information as one word following the Common Era BCD described above. Parity information is a value determined by running exclusive OR (XOR) at the individual word level for 35AC h, process input data and time information. Time information is used to prevent data falsification.
M51. IO-Link cycle time - Process value-	R	Each port	0.1 ms increments	Display the communication cycle time with the actual IO-Link device.
M52. IO-Link transmission rate	R	Each port	Unused	Communication is not established with the IO-Link device.
			COM1 (4800bps)	Communicating over COM1 with the IO-Link device.
			COM2 (38.4kbps)	Communicating over COM2 with the IO-Link device.
			COM3 (230.4kbps)	Communicating over COM3 with the IO-Link device.

Setting Items (setting value number followed by setting name)	R/W	Setting for product or port	Setting value range	Description
M53. Number of IO-Link communication errors	R	Each port	0 - 255	Display the number of communication errors with the IO-Link device. This will be cleared if written or if the power is cycled.
M54. ISDU checksum error	R	Each port	0 - 255	Display the number of ISDU communication checksum errors with the IO-Link device. This will be cleared if written or if the power is cycled.
M55. IO-Link transmission rate error	R	Each port	0.1% increments	Display the communication speed measurement error for the IO-Link device. Check the number of communication errors if the measurement error is +/-3% or higher.
M56. IO-Link signal width error	R	Each port	0.1% increments	Display the ON/OFF ratio measurement error for IO-Link device communication signals. Check the number of communication errors if the measurement error is +/-20% or higher.
M57. Communication mode	R	Each port	NOCOM	IO-Link has not started communication.
			STARTUP	Reading basic information for the IO-Link device. The process will stop here if there is a revision ID error.
			PREOPERATE	In a state prior to exchanging process data.
			OPERATE	Exchanging process data and operating.
			STARTUP (Rev.1.0)	Same as above.
			PREOPERATE (Rev.1.0)	However, this indicates the IO-Link device has a revision ID of 1.0 (10 h).
			OPERATE (Rev.1.0)	
M58. Storage backup time	R	Each port	Time and date	Display the time when storage data was backed up. This will be displayed as "00:00:00 00/00/00" if there is no backup data. The date will be written as YY/MM/DD (for Japanese, Korean, Chinese and Traditional Chinese), MM/DD/YY (for English) or DD/MM/YY (other languages).
M60. System program version of IO-Link master	R	This product	P.PPNNLLFF	Display the data version of the program, etc. P,PP: Firmware, NN: Network chip, LL: Logic, FF: Font
M61. Total operation hours of IO-Link master	R	This product	Displayed in 0.1 hour increments	Display the total cumulative operation time of this product since the power was first turned ON. This is counted internally in 7.5 minute increments, so any time under 7.5 minutes when the power is turned OFF will be discarded.
M62. Display drive time	R	This product	Displayed in 0.01 hour increments	Display the time the display was displayed since the power was first turned ON. This is counted internally in 56 second increments, but is written to memory every 7.5 minutes (as with the operation hours). After 100 hours have elapsed, it will automatically turn OFF if a button is not operated for 10 minutes.
M63. I/O power supply voltage	R	This product	0.1 V increments	Display the voltage of the I/O power supply. The measurement error is +/-5%.
M64. Internal temperature	R	This product	0.1°C increments	Display the internal temperature. The measurement error is +/-2°C.
M65. Network time	R	This product	Time and date	For CC-Link IE TSN, this product displays the network time (time and date) taking the time zone -UTC- (setting value number: M6) into consideration. For CC-Link IE Field, this product obtains time information only once during startup and then updates and displays it. The date will be written as YY/MM/DD (for Japanese, Korean, Chinese and Traditional Chinese) or MM/DD/YY (for English). It will be written as DD/MM/YY for other languages.

Setting Items (setting value number followed by setting name)	R/W	Setting for product or port	Setting value range	Description	
M66. Network communication cycle	R	This product	0.00 - 15.00 ms	Display the cycle at which process data is sent to and received from the host network. It will be forced to operate at a 15 ms cycle if the host network is disconnected.	
M81. Subnet mask	RW	This product	0.0.0.0 to 255.255.255.255	Set if otherwise specified on the field network. If not, keep the default value. The default value is 255.255.255.0. This is valid only when <i>M2. Network type</i> is <i>CC-Link IE TSN</i> . This setting cannot be changed using OMRON Support Software Wave Inspire HUB.	
M82. IP address	RW	This product	0.0.0.0 to 255.255.255.255	Set the first to third octets of IP address of this product to any value. The fourth octet (n) can only be set with the rotary switch. The initial value for the product's IP address is 192.168.250.n. Turning the front rotary switches of this product while the power is on will automatically switch to <i>M82. IP address</i> setting window. This is valid only when <i>M2. Network type</i> is <i>CC-Link IE TSN</i> . This setting cannot be changed using OMRON Support Software Wave Inspire HUB.	
M83. IE TSN Class settings	RW	This product	Class B (default value), Class A 1G, Class A 100M	If using CC-Link IE TSN communication, change certification class and transmission speed.	
C1. Device reset	W	Each port	No (default value)	Do not reset the device.	
			Reboot	Send system command 80 h to the IO-Link device.	If an IO-Link device with setting value information version 1 or later is connected, <i>C1. Device reset</i> will not be displayed. In this case, send any system command (supported by the applicable device) to index number 02 (system command) from the device setting values window.
			Application reset	Send system command 81 h to the IO-Link device.	
			Reset factory setting	Send system command 82 h to the IO-Link device.	
			Back-to-box	Send system command 83 h to the IO-Link device.	

Note M29 and M52-M66 described above will not be displayed using the up and down buttons in the Master Unit parameter menu. Enter the setting value number directly to navigate. The up and down buttons can be used to select for 10 minutes after navigating.

7

Troubleshooting

This section describes how to carry out troubleshooting and provides other useful information on using this product.

7-1	Troubleshooting	7-2
7-1-1	Troubleshooting Based on LEDs	7-2
7-1-2	Troubleshooting Based on Symptoms.....	7-4
7-1-3	Error Code List	7-8

7-1 Troubleshooting

7-1-1 Troubleshooting Based on LEDs

Front LEDs (on this product)		Status	Details	Procedure
EVENT	ALAR M			
Flashing yellow	-	Event occurring in IO-Link device	An event has occurred in the IO-Link device connected to a port. The <i>Event flag</i> (assigned to RX17 on the host master station) also turns ON. The applicable port is also stored in <i>Latest event port</i> (assigned to RX10 - 13 on the host master station).	The event code can be read using the following procedures. <ul style="list-style-type: none"> Using acyclic communication, read from <i>Read event data</i> in Master Unit parameters Check the <i>Event/error display window</i> on the front of this product Then, implement the required measures based on the event code of each IO-Link device.
-	Flashing red	Error occurring in this product	An error has occurred in this product. The <i>Error flag</i> (assigned to RX1F on the host master station) also turns ON. The applicable port is also stored in <i>Latest error port</i> (assigned to RX18 - 1B on the host master station).	The error code can be read using the following procedures. <ul style="list-style-type: none"> Using acyclic communication, read from <i>Read latest error code by port</i> in Master Unit parameters Check the <i>Event/error display window</i> on the front of this product Refer to <i>7-1-3 Error Code List</i> on page 7-8 and implement the required measures.

Front LEDs (on this product)		Status	Details	Procedure
NW READ Y	NW COMM			
Lit blue-green	-	IC inside CC-Link IE Field/TSN startup	The CC-Link IE Field or CC-Link IE TSN network chip is started.	-
Off	-		The CC-Link IE Field or CC-Link IE TSN network chip does not work.	If the RUN LED does not stay ON (blue-green) even though the power is ON, check the POWER LED.
Lit blue-green	Lit blue-green	CC-Link IE Field/TSN communication status	Communicating normally with the CC-Link IE Field or CC-Link IE TSN master station.	-

Front LEDs (on this product)		Status	Details	Procedure
NW READY	NW COMM			
Lit blue-green	Flashing blue-green		Communication disconnection	<ul style="list-style-type: none"> • Confirm the status of the CC-Link IE Field/TSN master station. • Confirm the status of the CC-Link IE Field/TSN cable. • Confirm the status of the switching hub between the CC-Link IE Field/TSN master station and this product. • Reset the CPU module of the host PLC. • Reset the CPU module of the host PLC after setting and writing the CC-Link IE Field/TSN master station parameters. • Reset the CPU module of the host PLC after setting and writing the parameters that were registered in the CC-Link IE Field/TSN master station, in the module connected to the host PLC. (refer to the manual of the CC-Link IE Field/TSN master station being used). • Confirm the following if no problems are found. <ol style="list-style-type: none"> a) Network number b) Station number
			Network synchronization signal error	<p>The IO-Link cycle time cannot be synchronized with the link scan time/communication cycle of the host CC-Link IE Field/TSN network.</p> <p>This is an internal network synchronization signal error, so the product will need to be repaired or replaced.</p>
-	Off		Not communicating	<ul style="list-style-type: none"> • Confirm the following. <ol style="list-style-type: none"> a) Communication wiring with the CC-Link IE Field/TSN master station b) Station number setting on the front of this product c) The network number set for this product and the CC-Link IE Field/TSN master station d) The status of the host master station e) Has this product been registered in the GXWorks2/3 network configuration? f) Has the CC-Link IE Field/TSN master station been registered as a module? • Reset the CPU module of the host PLC. • Reset the CPU module of the host PLC after setting and writing the CC-Link IE Field/TSN master station parameters. • Reset the CPU module of the host PLC after setting and writing the parameters that were registered in the CC-Link IE Field/TSN master station, in the module connected to the host PLC.

7-1-2 Troubleshooting Based on Symptoms

Phenomenon	LEDs on the front of this product	Cyclic communication flag	Error code (hexadecimal)	Probable cause		Procedure
Unable to communicate (IO-Link communication) with an IO-Link device	I/O PWR OFF	I/O power supply flag OFF	-	I/O power supply error	I/O power supply OFF error Below 12 V.	Confirm the voltage at the device terminal block (L+) or power terminal block.
	ALARM LED flashing red	IO-Link ready flag OFF and error flag ON	1001 (after IO-Link communication has been established once)	IO-Link communication error	The IO-Link cable is disconnected. The IO-Link cable is shorted.	Confirm that the IO-Link cable is connected.
					The IO-Link device has failed.	Replace the IO-Link device.
Data sent to/received from an IO-Link device via IO-Link communication cannot be read/written properly by CC-Link IE Field/TSN	ALARM LED OFF	-	-	Process data was read and written when IO-Link communication was not properly established with the IO-Link device.	Process data was not read with the IO-Link ready flag as the execution condition.	Read process data with the IO-Link ready flag ON.
					Process data was not written with the IO-Link ready flag as the execution condition.	Write process data with the IO-Link ready flag ON.
				When process data (in bytes) in the IO-Link device is expanded into words in the host master station, the high-order/low-order bytes are reversed.	Depending on the type of IO-Link device, process data from the low-order byte in the IO-Link device must be allocated as words in order from the high-order byte to the low-order byte in the host master station, when process data stored in bytes in the IO-Link device is allocated to the host master station.	Change the setting of <i>M43</i> . <i>Process data LSB/MSB</i> in the Master Unit parameters of this product from the default of <i>Little endian</i> to <i>Big endian</i> .

Phenomenon	LEDs on the front of this product	Cyclic communication flag	Error code (hexadecimal)	Probable cause	Procedure
				<p>Process data from an IO-Link device is not allocated to the host master station.</p> <p>The total process data for all connected IO-Link devices exceeds 256 words (512 bytes) for either input or output.</p> <p>The total process data for this product with all connected IO-Link devices is 256 words (512 bytes) for input, and 256 words (512 bytes) for output.</p> <p>These conditions must be satisfied when connecting the maximum of 16 devices to this product.</p> <p>If a total of 256 words (512 bytes) is exceeded for either input or output, the excess process data will not be allocated to the host master station.</p>	<ul style="list-style-type: none"> If there is process data that does not need to be allocated: Ensure that process data for all connected IO-Link devices does not exceed 256 words (512 bytes) for input and 256 words (512 bytes) for output. Set the following values to manually set the process data for each port (restrict and allocate the number of words for input or output for the IO-Link device on each port to this product). Process data words auto allocation (setting value number: M42): None Process input data words allocation (setting value number: M40) Process output data words allocation (setting value number: M41) If there is no process data that does not need to be allocated: Use an additional product to reduce the number of IO-Link devices connected to this product using IO-Link communication.
	EVENT LED flashing yellow	Event flag ON	-	Device event (error level) occurring in IO-Link device	Check the event/error display window or send a communication instruction from the host master station to read the event code. Refer to the manual for the IO-Link device being used and perform troubleshooting.
	ALARM LED flashing red	Error flag ON	FFFA	Host network communication stopped	Confirm the status of the host network (CC-Link IE Field/TSN).

Phenomenon	LEDs on the front of this product	Cyclic communication flag	Error code (hexadecimal)	Probable cause	Procedure
			FFFB	IO-Link device not connected	Confirm that the applicable IO-Link device is connected. Or, change the setting value for device verification (setting value number: M30) to <i>None</i> . Or, set the I/O assignment settings (setting value number: M10) to a value other than <i>IO-Link</i> for any ports not connected to an IO-Link device.
			FF23	The vendor ID or device ID differs between the stored data and the connected IO-Link device.	Confirm the vendor ID and device ID of the applicable IO-Link device. Or, clear the storage data.
			FFF3	The revision ID of the IO-Link device to verify is not registered in this product (00 h)	Change the setting value for device verification (setting value number: M30) to <i>None</i> . Or, register the revision ID of the IO-Link device to verify.
			FFF4	IO-Link device verification error (type name mismatch)	If the correct IO-Link device is currently connected, overwrite with this setting value (<i>Type name</i>) to re-register with the type name of the currently connected IO-Link. Or, connect the correct IO-Link device.
			FFFC	IO-Link device verification error (serial number mismatch)	If the correct IO-Link device is currently connected, overwrite with this setting value (<i>Serial number</i>) to re-register with the serial number of the currently connected IO-Link device. Or, connect the correct IO-Link device.

Phenomenon	LEDs on the front of this product	Cyclic communication flag	Error code (hexadecimal)	Probable cause	Procedure
			FFFE	IO-Link device verification error (vendor ID or device ID mismatch)	If the correct IO-Link device is currently connected, overwrite with this setting value (<i>Type ID</i>) to re-register with the vendor ID and device ID of the currently connected IO-Link device. Or, connect the correct IO-Link device.
			6001	IO-Link device verification error (revision ID mismatch)	If the correct IO-Link device is currently connected, overwrite with this setting value (a value other than <i>None (default value)</i>) to re-register with the revision ID of the currently connected IO-Link. Or, connect the correct IO-Link device.
Storage data cannot be restored to the IO-Link device using the manual backup/restore of settings or automatic device parameter backup functions.	ALARM LED flashing red	Error flag ON	FFFD	No backup data found in this product	Backup the setting values from the applicable IO-Link device to this product.
			FFFF	The type ID of the IO-Link device to restore does not match	Confirm the type ID of the applicable IO-Link device.
Unable to perform the following using GXWorks2/3 <ul style="list-style-type: none"> Parameter reading Parameter writing CC-Link IE Field network diagnosis 	ALARM LED OFF	-	-	The version of GXWorks2/3 is not supported.	Update GXWorks2/3 to the latest version.
				Network parameter (or network module parameter) settings are not correct.	Set the correct network parameters (or network module parameters) based on the network number and station number that are actually connected, write them to the host PLC, and then reset the CPU module of the PLC.
Cannot connect to Mitsubishi Electric's motion module via CC-Link IE TSN.	NW COMM LED (Blue-green) OFF	-	-	This product is recognized as the motion control station.	In GX Works2/3 <i>CC-Link IE TSN Configuration</i> , remove the <i>check mark</i> from the check box in the <i>Motion Control Station</i> table.

7-1-3 Error Code List

Code (hexadecimal)	Message	Conditions	Procedure
1000	Device has ISDU No Service	This occurs when the start code of the ISDU communication response used to access the setting value for the IO-Link device is "0" (No Service).	A setting value that is not supported by the IO-Link device is being accessed in this case. Confirm what you are trying to access (index number, etc.). This ISDU handling error may occur when the power supply to the IO-Link device is unstable. Use a power supply with sufficient capacity.
1001	IO-Link communication is stopped	This occurs when communication is established with an IO-Link device but then is disconnected. This error does not occur if the I/O power supply is shut-down. The error is also automatically cleared if IO-Link communication is restored.	Check the wiring between the IO-Link device and this product. Check the I/O power supply. Confirm whether the issue is resolved after changing the connection to another port for this product or replacing the IO-Link device and cable.
1100	ISDU timeout is occurred	When using ISDU communication to access an IO-Link device setting value, no ISDU communication response is received even after five seconds have passed.	Confirm what you are trying to access on the IO-Link device (index number, write data, etc.).
5600	ISDU checksum error is occurred	When using ISDU communication to access an IO-Link device setting value, a mismatch occurs when calculating the checksum of the ISDU communication response.	This could be caused by noise between the IO-Link device and this product. Resolve this through such means as using a separate conduit for the power line, or maintaining distance between the C/Q wires of other IO-Link devices (do not bundle wires together). Confirm that the cable between the IO-Link device and this product is not too long (over 20 m).
5700	Illegal ISDU data length	This occurs when the data length of the ISDU communication response is either "0" or too long, when using ISDU communication to access an IO-Link device setting value.	
6001	IO-Link revision ID is not matched	The revision ID registered in this product does not match the revision ID of the connected IO-Link device. Process data is not transferred and setting values are not accessed.	Change the setting value for device verification (setting value number: M30) to <i>None</i> .
8033	Parameter length is overrun	This occurs when the data length is too long, when using ISDU communication to access an IO-Link device setting value.	Write data using the data length specified for the IO-Link device.
FF23	Data storage identification mismatch	This occurs when the value of the vendor ID or device ID of the connected IO-Link device differs from the stored storage data, when device verification (setting value number: M30) is set to <i>None</i> and storage data exists (however, this only occurs when power is turned ON).	If an IO-Link device with a vendor ID or device ID that differs from the storage data is connected, connect the correct IO-Link device. If it is safe to delete the storage data stored on this product, write with device parameter backup/restore (setting value number: M32) set to <i>Delete</i> .
FF24	Data storage buffer overflow	This occurs when setting value data is too long and cannot be stored, when backing up setting values from an IO-Link device. The data length stored during backup will be $16 \text{ bytes} + \text{index } 18 \text{ (type name) length} + \text{number of setting values to backup} \times 4 + \text{total data length of setting values to backup}$. This can be stored as long as it is 4,032 bytes or less.	Backup cannot be performed for the connected IO-Link device because the storage data is too large.
FF25	Data storage parameter access denied	This occurs when access to storage data is locked on the IO-Link device.	If this is required, release the lock setting (index number 12) on the IO-Link device.
FFEA	Duplicate IP address	A module was connected with an IP address (station number) that is the same as an address set in CC-Link IE TSN.	Confirm the station number of the module that was connected.
FFEB	ISDU communication conflict has caused a timeout	While attempting to perform ISDU communication on the same IO-Link port, ISDU communication was being used elsewhere and communication could not be performed within a time 330 times the cycle time.	Storage takes some time, so wait a short while and try ISDU communication again (access by index number to IO-Link device).

Code (hexadecimal)	Message	Conditions	Procedure
FFEC	EEPROM write protection signal error	The write protection signal is always permitted for the EEPROM used for saving setting values, etc.	This will not cause any immediate issues with operation. However, this indicates a hardware error and the hardware will need to be replaced.
FFED	EEPROM writing failed	Setting value, storage data and operation time writing failed.	There is something wrong with the connection to the EEPROM, or the EEPROM has reached its maximum number of writes. It can be rewritten 1,000,000 times.
FFEE	IO-Link trace has stopped automatically	This is a notification indicating that IO-Link tracing has stopped due to an error occurring or the buffer being full.	Read the IO-Link trace data and confirm communication information.
FFEF	Storage is aborted	An error response was received from the IO-Link device while backing up to or restoring from storage, and the storage stopped operating. Backed up data will not be saved. The data being restored may have partially been transferred to the IO-Link device.	Perform the storage operation (backup or restore) again. If this occurs again, it may be due to noise. If so, resolve this through such means as using a separate conduit for the power line, or maintaining distance between the C/Q wires of other IO-Link devices (do not bundle wires together). Confirm that the cable between the IO-Link device and this product is not too long (over 20 m). If this still occurs, it may be caused by the firmware of the IO-Link device or this product. If so, update or replace the firmware of the IO-Link device or this product.
FFF0	Illegal character on parameter information	There is an invalid character in the setting value information provided by the IO-Link device, or a value exceeding the permitted value was specified.	This is caused by the firmware of the IO-Link device or this product. Update or replace the firmware of the IO-Link device or this product.
FFF1	Illegal firmware data to update	An attempt to write invalid data was made when updating the firmware.	There is something wrong with the data (the CSV file being imported) for the firmware being written. Reacquire the file and try again.
FFF2	Invalid MAC address	An invalid MAC address is registered in this product.	Flash memory containing data such as the MAC address could not be read properly. If this occurs again even after cycling the power, it indicates that a failure has occurred.
FFF3	No Device ID is stored to verify	This occurs when the revision ID registered to this product is "00 h", when device verification (setting value number: M30) is set to a value other than <i>None</i> .	Change the setting value for device verification (setting value number: M30) to <i>None</i> . Or, register the revision ID of the IO-Link device to verify.
FFF4	IO-Link device type name is not matched	This occurs when the type name (index number 18 [product name] character string) of the registered IO-Link device differs from the type name of the device that is actually connected, when device verification (setting value number: M30) is set to <i>Type name</i> . Cyclic communication is not performed with the applicable IO-Link device.	Change the setting value for device verification (setting value number: M30) to a value other than <i>Type name</i> . Or, connect the correct IO-Link device.
FFF5	Parameter version is not supported	The version of the setting value data restored to setting value memory is new, and it may not be possible to recognize some of it.	Update the firmware of this product.
FFF6	Internal Temperature is too high	This occurs when the temperature of the main CPU exceeds 85°C. The error occurs every 10 minutes.	Lower the operating temperature of this product, install a cooling fan, or lower the output load current (for example, by using a separate relay).

Code (hexa-decimal)	Message	Conditions	Procedure
FFF7	Parameter writing with a high frequency	The setting value write count occurs under the following conditions. <ul style="list-style-type: none"> The count is cleared if nothing is written for 450 seconds. When 2 writes are made at once in less than 1 second. When 20 writes are made at once in less than 10 second. When 200 writes are made at once in less than 110 second. 	Confirm whether setting value write operations are being performed frequently from the host PLC. Confirm whether IO-Link device setting values are frequently rewritten, with automatic device parameter backup (setting value number: M31) set to <i>Backup</i> or <i>Both</i> .
FFF8	Firmware versions are not compatible	There is version incompatibility with the main firmware, host network communication firmware or IO-Link communication logic, and some functions may not operate normally.	Update the FPGA data of this product and the network chip firmware.
FFF9	The network chip doesn't work	This occurs when there is no communication between the main CPU and the chip that is performing host network processing.	The network chip may have failed, or power may have turned OFF while the network chip firmware was being updated. Try updating over RS-232C if possible.
FFFA	The network communication was stopped	This occurs when host CC-Link IE Field/TSN communication is established but then is disconnected. The error will be automatically cleared when the status is restored.	Check whether the Ethernet cable is disconnected, the host PLC has been reset, or the power has turned OFF. Confirm the host PLC parameters. This product may stop being recognized on the network if host PLC network settings are changed.
FFFB	No IO-Link device is connected	This occurs when the IO-Link device is not connected under the following conditions. <ul style="list-style-type: none"> The IO-Link device is not connected when running storage functions (manual or automatic backup/restore of IO-Link device) Ten seconds elapse without the IO-Link device connecting after the I/O power supply is turned ON, when device verification (setting value number: M30) is set to a value other than <i>None</i> The IO-Link device is not connected when confirming device information or reading/writing a setting value number from the device setting values window The user switched to the device setting value window when connected to a device that does not support IS-DU communication 	Connect the IO-Link device properly. Or, change the setting value for device verification (setting value number: M30) to <i>None</i> . Or, set the I/O assignment settings (setting value number: M10) to a value other than <i>IO-Link</i> for any ports not connected to an IO-Link device.
FFFC	Serial number verify error	This occurs when the registered serial number differs from the serial number of the connected IO-Link device, when device verification (setting value number: M30) is set to <i>Serial number</i> . Cyclic communication is not performed with the applicable IO-Link device.	Change the setting value for device verification (setting value number: M30) to a value other than <i>Serial number</i> . Or, connect the correct IO-Link device.
FFFD	No Backup data is available	This occurs when storage data is not saved in this product, when restoring storage data to an IO-Link device.	Backup must be executed before restoration. Select <i>Backup</i> in device parameter backup/restore (setting value number: M32) and execute backup.
FFFE	IO-Link device ID is not matched	This occurs when the registered vendor ID or device ID differs from the value of the connected IO-Link device, when device verification (setting value number: M30) is set to a value other than <i>None</i> . Cyclic communication is not performed with the applicable IO-Link device.	Change the setting value for device verification (setting value number: M30) to <i>None</i> . Or, connect the correct IO-Link device.
FFFF	Different device ID to restore	This occurs when the vendor ID or device ID differs when storage data is restored (manual restore or automatic restore) to an IO-Link device.	Connect the correct IO-Link device.

*1. Errors will be ignored if the same error code occurs within one second on the same port.

- *2. Up to 20 entries will be stored across all ports in the buffer used to store error information. Error information will begin being discarded beginning with the oldest entry when the number of entries exceeds 20.



Appendices

This section describes how to replace an IO-Link device and includes some acyclic communication sample programs.

A-1	Acyclic Communication Sample Programs	A-2
A-1-1	For CC-Link IE Field	A-2
A-1-2	For CC-Link IE TSN	A-3

A-1 Acyclic Communication Sample Programs

A-1-1 For CC-Link IE Field

Example of Reading the IO-Link Device Data by Transient Communication

(JP.RIRD instruction)

Ex.: Reading the product name **Index 18 (0x12)**, **Subindex 0** of the IO-Link device E3AS-HL connected to port 1 of this product.

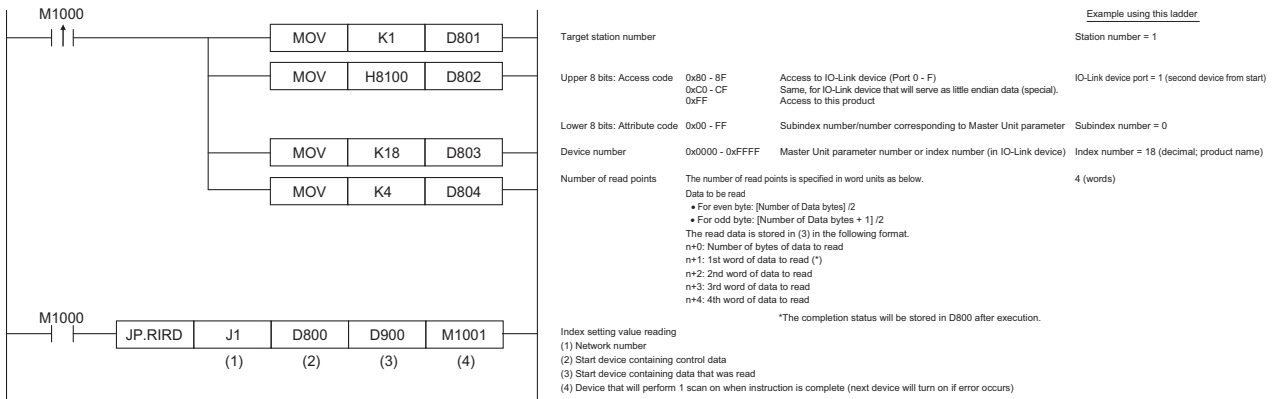

Example of Writing the IO-Link Device Data by Transient Communication

JP.RIWT instruction

Ex.: Writing the string **ABCDEFGH** to the user tag name **Index 24 (0x18)**, **Subindex 0** of the IO-Link device connected to port 1 of this product.

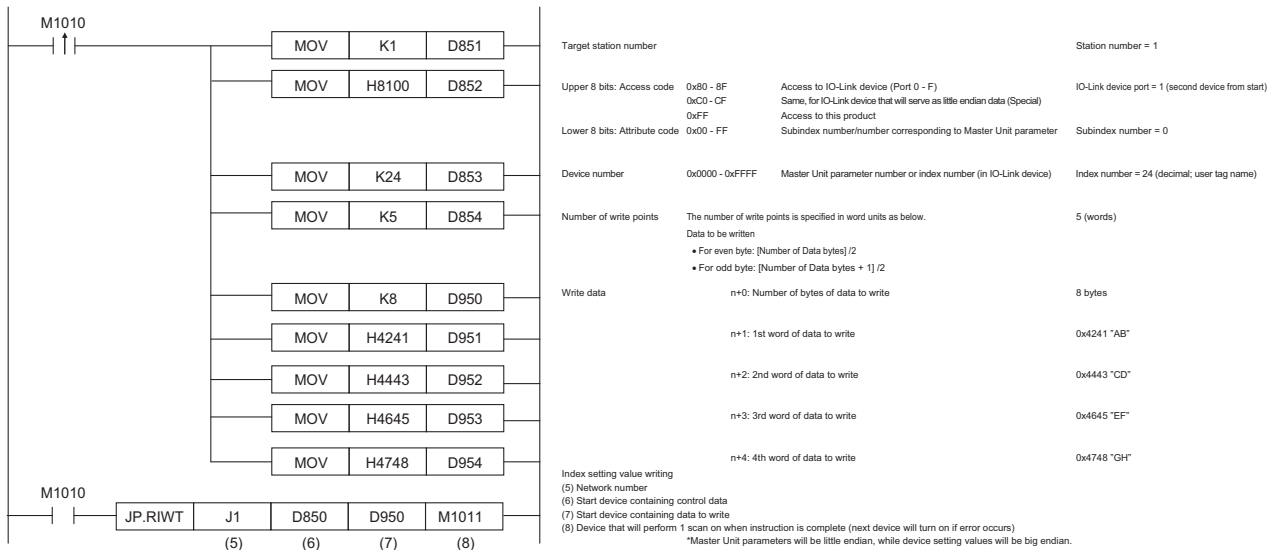

A-1-2 For CC-Link IE TSN

Example of Reading the Setting Value of This Product by Transient Communication

(JP.SLMPSND instruction)

Ex.: Reading the display string **Index 263 (0x107), Subindex 0** of this product's OLED display

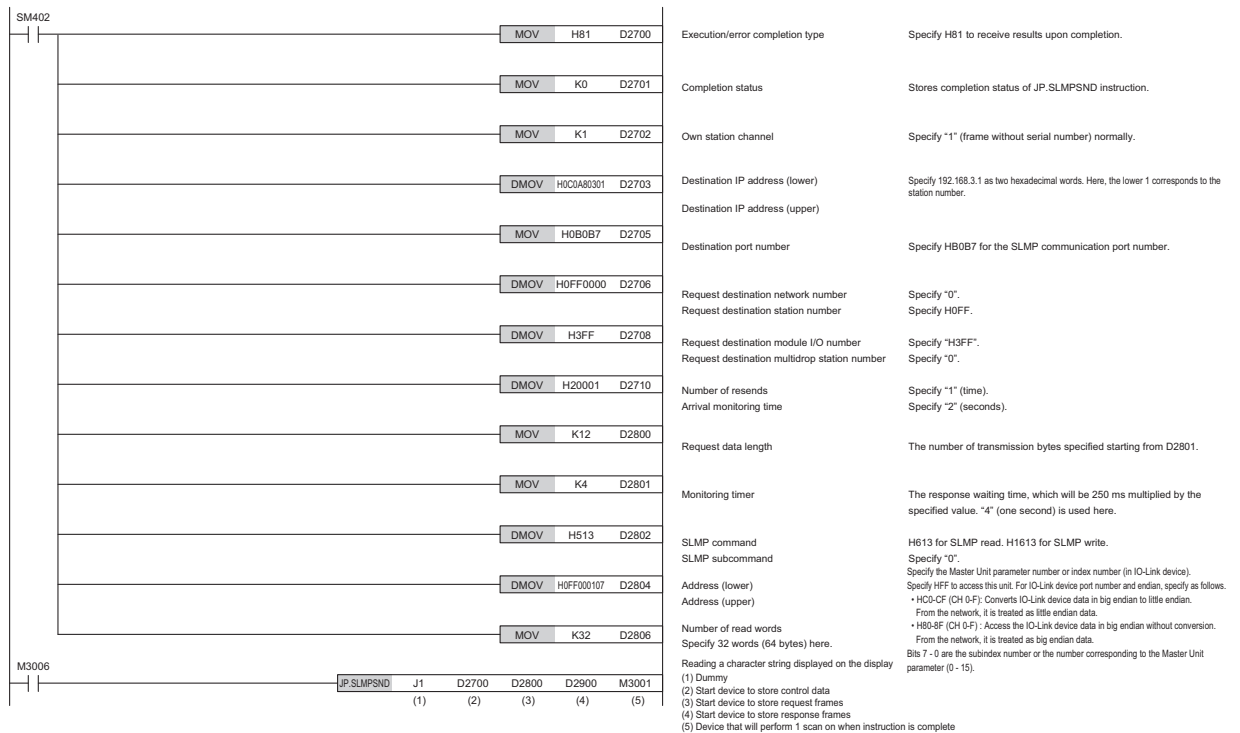

Example of Writing the Setting Value of This Product by Transient Communication

(JP.SLMPSEND instruction)

EX.: Writing NPN Input **2** to Function Setting **Index 10 (0xA)**, **Subindex 0** of Master Unit Parameter M10.I/O of this Product

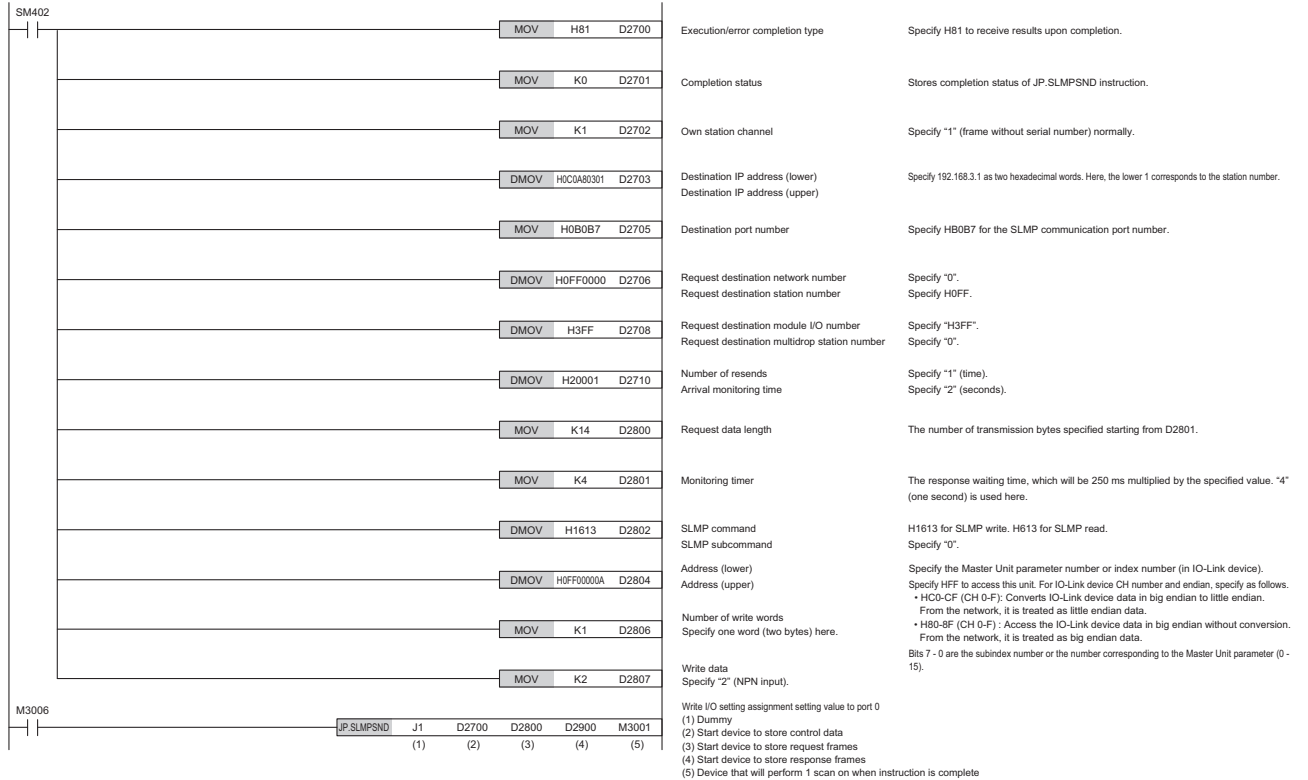



Index



Index

- A**
- Access..... 3-24
 - Access completed..... 3-27
 - Access error..... 3-26
 - Acyclic communication..... 4-3
 - Acyclic communication (transient transmission and ISDU communication)..... 19
 - Applicable IO-Link port..... 3-25
 - Auto restoration..... 6-21
 - Automatic device parameter backup..... 4-7, 6-21
- B**
- Button operation..... 6-31
 - Byte length or target selection to access..... 3-25, 3-29
- C**
- CC-Link IE Field..... 6-13, 6-38
 - CC-Link IE Field communication..... 3-38
 - CC-Link IE TSN..... 6-13, 6-38
 - CC-Link IE TSN communication..... 3-38
 - Clear the latest error..... 3-21, 3-23
 - Clear the latest event..... 3-23
 - Conditions for applying IODD data..... 6-22
 - Cyclic communication..... 4-2
 - Cyclic communication (cyclic transmission and process I/O communication)..... 19
- D**
- Device ID..... 21
 - Device parameter backup/restore..... 6-22
 - Device verification..... 21, 4-4, 6-20
 - Digital input (port 0-F)..... 3-22
 - Digital output (port 0-F)..... 3-23
 - Display brightness..... 6-13
 - Display drive time..... 4-9, 6-26
- E**
- Encoder input (high-speed counter function)..... 4-8
 - Error..... 3-21
 - Error code..... 20
 - Error flag..... 20, 3-23
 - Ethernet cable..... 17
 - Event..... 3-21
 - Event communication..... 19, 4-3
 - Event flag..... 20, 3-23
 - Extended access..... 3-25
 - Extended access enable flag..... 3-23, 3-28
 - Extended access enabled..... 3-21, 3-22
 - Extended access read data..... 3-25, 3-28
 - Extended access write data..... 3-25, 3-29
- F**
- Find Me requests..... 6-32
- G**
- GD-ILM16C/E-CLI..... 3-25
 - General-purpose hub..... 17
 - GXWorks2/3..... 3-3
- I**
- I/O assignment batch settings..... 6-14
 - I/O assignment settings..... 19, 6-15
 - I/O power supply..... 3-21
 - I/O power supply flag..... 3-23, 4-9
 - I/O power supply voltage..... 4-9, 6-26
 - I/O synchronization..... 20, 4-6, 6-18
 - I/O synchronization setting..... 4-6
 - Index number or setting value number specification..... 3-25, 3-28
 - Input filter time..... 4-8, 6-15
 - Input hold time..... 4-8, 6-15
 - Internal temperature..... 4-9, 6-27
 - IO-Link..... 6-24
 - IO-Link communication and network error handling..... 21, 4-4, 6-15
 - IO-Link communication mode..... 6-25
 - IO-Link cycle time..... 6-24
 - IO-Link master..... 6-14
 - IO-Link Mode..... 6-15
 - IO-Link Ready..... 3-21
 - IO-Link ready flag..... 20, 3-23, 4-5
 - IO-Link signal width error..... 6-25
 - IO-Link transmission rate error..... 6-25
- L**
- Language..... 6-13
 - Latest error port..... 3-21, 3-23
 - Latest event..... 3-21, 3-22
 - Latest Event port..... 3-21, 3-23
 - Little endian access..... 3-25, 3-27
- M**
- Manual backup/restore of settings..... 4-7
 - Master Unit parameters reset..... 6-12
- N**
- Network..... 6-13
 - Network communication cycle..... 6-27
 - Network No..... 6-13
 - Network synchronization..... 20, 4-6
 - Network synchronization signal error..... 7-3

Network synchronous.....	6-41	Vendor ID.....	21
Network time.....	4-6, 6-27	W	
NPN output mode.....	6-15	Write.....	3-25
Number of IO-Link communication errors.....	4-9, 6-24	Write request.....	3-27
O			
Operating time.....	6-26		
Output overcurrent.....	3-21		
Output overcurrent flag.....	3-23, 4-9		
P			
PNP output mode.....	6-15		
Port.....	20		
Port No. of IO-Link to access (0 to F).....	3-27		
Process data automatic allocation/manual setting.....	4-3		
Process data sequence conversion.....	21, 4-5, 6-23		
Process data words auto allocation.....	6-23		
Process input data.....	3-24		
Process input data words allocation.....	6-22		
Process output data.....	3-24		
Process output data words allocation.....	6-23		
R			
Read.....	3-25		
Read request.....	3-27		
Reset encoder counter.....	3-21 – 3-23		
Revision ID.....	21		
RIRD instruction (readout), RIWT instruction (write).....	3-41		
RIRD/RIWT instructions:.....	3-31		
S			
Serial No.....	6-42		
Setting with GXWorks2/3.....	3-19		
SLMPSND instruction.....	3-41		
SLMPSND instructions.....	3-31		
Storage backup time.....	6-26		
Storage of time read from IO-Link device setting value.....	4-6		
Subindex number.....	3-29		
Subindex number or target number.....	3-25		
Synchronization establishment.....	3-21		
Synchronization establishment flag.....	3-23, 4-6		
System program version of IO-Link master.....	6-26		
T			
Time stamp.....	6-24		
Time zone.....	6-14		
Total operation hours of IO-Link Master Unit.....	4-9		
TSN hub.....	17		
Type ID.....	21, 6-42		
Type ID (vendor ID and device ID) verification.....	6-20		
Type ID and device type name verification.....	6-20		
Type name.....	6-42		
V			

OMRON Corporation Industrial Automation Company

Kyoto, JAPAN

Contact : www.ia.omron.com

Regional Headquarters

OMRON EUROPE B.V.

Wegalaan 67-69, 2132 JD Hoofddorp
The Netherlands
Tel: (31) 2356-81-300 Fax: (31) 2356-81-388

OMRON ELECTRONICS LLC

2895 Greenspoint Parkway, Suite 200
Hoffman Estates, IL 60169 U.S.A.
Tel: (1) 847-843-7900 Fax: (1) 847-843-7787

OMRON ASIA PACIFIC PTE. LTD.

438B Alexandra Road, #08-01/02 Alexandra
Technopark, Singapore 119968
Tel: (65) 6835-3011 Fax: (65) 6835-3011

OMRON (CHINA) CO., LTD.

Room 2211, Bank of China Tower,
200 Yin Cheng Zhong Road,
PuDong New Area, Shanghai, 200120, China
Tel: (86) 21-6023-0333 Fax: (86) 21-5037-2388

Authorized Distributor:

©OMRON Corporation 2026 All Rights Reserved.
In the interest of product improvement,
specifications are subject to change without notice.

Cat. No. Z513-E1-02 0426